

ARCHITECTURAL GRILLE

Grille Type	Linear Bar
Material	Extruded Aluminum (Alloy 6063-T5)
Thickness	0.081 to 0.250 in. (2.06 to 6.35 mm)
Grille Depth	2 to 6 in. (50.8 to 152.4 mm)
Perimeter Frame	Aluminum Bar, Channel or Tube
Horizontal Bar Spacing	2 to 12 in. (50.8 to 304.8 mm)
Vertical Bar Spacing	2 to 12 in. (50.8 to 304.8 mm)

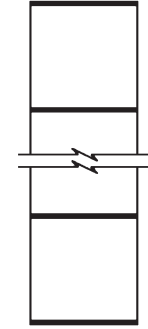

SECTION VIEW

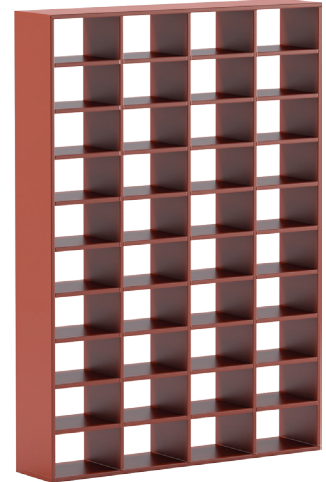

RECOMMENDED SPECIFICATION

Airolite Linear Bar Grilles are designed and produced to your custom specification to function as architectural accent elements or entire facades that yield sight and solar screening or serve as security barriers. Linear Bar Grilles are produced in configurations from 2" (50.88 mm) to 6" (152.4 mm) deep and with extruded aluminum members that range in thicknesses from 0.081" (2.06 mm) to 0.250" (6.35 mm). Horizontal and vertical bar spacing can be configured from 2" (50.8 mm) minimum to 12" (304.8 mm) maximum center spacing to yield desired sightlines. All materials are available in Airolite's broad array of baked enamel, fluoropolymer and clear or color anodize coatings for durability and compatibility with adjacent components. Please contact your local Airolite representative or the factory for assistance with the layout and design of support systems when required.

GENERAL

Where indicated on plan drawings or described in schedules, furnish and install Linear Bar Grilles as designed and manufactured by The Airolite Company LLC, Schofield, Wisconsin. Grilles shall be furnished in the configurations represented on the plan drawings and shall include supports, installation hardware and finishes as specified and required for a complete installation.

SUBMITTALS

Manufacturer shall submit shop drawings incorporating key plans, elevations, sections and details showing profiles, angles and spacing of components and frames; unit dimensions related to wall openings and construction; and, anchorage details and locations. Submit theoretical calculations prepared by a professional engineer specializing in the application of welding technology demonstrating that each fillet weld joining blade and frame members will withstand a minimum of 526 pounds of force in shear. Provide samples of manufacturer's finish and color charts showing the full range of finishes and colors available.

PRODUCTS

Architectural grilles shall be Airolite Linear Bar Grilles as follows:

- Material: Extruded Aluminum, Alloy 6063-T5
- Material Thickness: Specify 0.081" (2.06 mm) to 0.250" (6.35 mm) , or as indicated.
- Grille Depth: Specify 2" (50.8 mm) to 6" (152.4 mm), or as indicated.
- Perimeter Frame: Specify Bar, Channel or Tube, or as indicated.
- Horizontal Bar Spacing: Specify 2" (50.8 mm) to 12" (304.8 mm), or as indicated.
- Vertical Bar Spacing: Specify 2" (50.8 mm) to 12" (304.8 mm), or as indicated.

WELDED ASSEMBLY

Join stationary blade, head, sill and jamb frames with fillet welds concealed from view. Louver blades shall be joined to each jamb frame with fillet welds produced with the Pulsed Gas Metal Arc Welding (GMAW/Mig) process.

STRUCTURAL DESIGN CRITERIA

Manufacturer shall design and furnished all supports required to withstand a wind force of not less than 25 pounds per square foot. Grilles 120-inches (3,048 mm) wide x 120-inches (3,048 mm) high will be fabricated and installed in multiples sections (one dimension cannot exceed 72-inches). Grille members, frames, mullions and anchorages shall be demonstrated to withstand the specified wind design load.

See page 2 for complete finish options

GRILLE TYPE LINEAR BAR DETAILS & FINISH OPTIONS

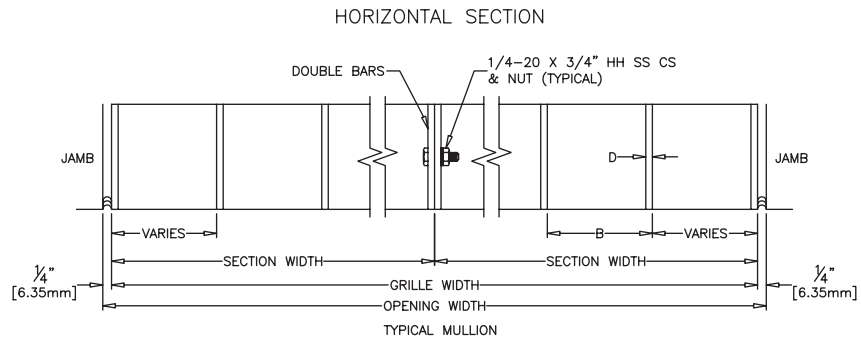
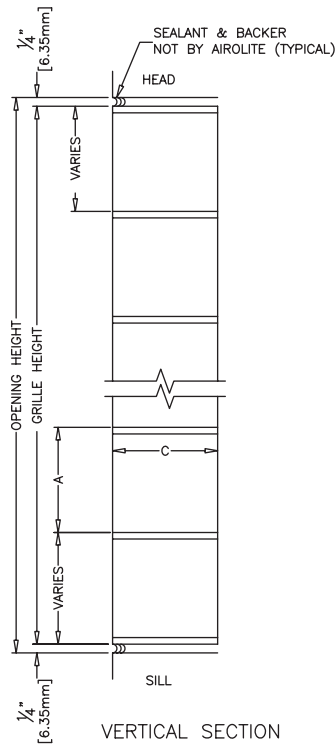

- A - Horizontal Bar Spacing**
Specify horizontal members on minimum 2" (50.8 mm) to maximum 12" (304.8 mm) center spacing.
- B - Vertical Bar Spacing**
Specify vertical members on minimum 2" (50.8 mm) to maximum 12" (304.8 mm) center spacing.
- C - Grille Depth**
Specify minimum 2" (50.8 mm) to maximum 6" (152.4 mm) depth.
- D - Aluminum Thickness**
Specify minimum 0.081" (2.06 mm) to maximum 0.250" (6.35 mm) Extruded Aluminum (alloy 6063-T5) wall thickness.

FINISHES

Finish Type	Description/Application	Color Selection	Standard Warranty (Aluminum)
AAMA 2605 100% Fluoropolymer (FEVE) 2-Coat 70% Kynar® (PVDF) 3-Coat 70% Kynar® (PVDF) 4-Coat 70% Kynar® (PVDF)	"Best." The premier finish for extruded aluminum. Tough, long-lasting coating has superior color retention and abrasive properties. Resists chalking, fading, chemical abrasion and weathering.	Standard Colors: Any of the 27 standard colors shown can be furnished in 70% or 50% Kynar®, 100% Fluoropolymer or Baked Enamel. Mica Colors: Aiolite offers 6 standard Mica colors for 70% Kynar® or 100% Fluoropolymer. Custom Colors: Custom color matching is available. Consult your Aiolite representative for cost and/or lead-time implications if a custom color is required.	10 Years (20 Years Optional)
AAMA 2603 Baked Enamel	"Good." Provides good adhesion and resistance to weathering, corrosion and chemical stain.		1 Year
AA-M10C22A42 Integral Color Anodize	"Two-step" anodizing is produced by following the normal anodizing step with a second, colorfast process.	Light, Medium, Dark or Extra Dark Bronze; Champagne; Black	5 years
AA-M10C22A41 Clear Anodize 215 R-1	Clear, colorless and hard oxide aluminum coating that resists weathering and chemical attack.	Clear	5 years
AA-M10C22A31 Clear Anodize 204	Clear, colorless and hard oxide aluminum coating that resists weathering and chemical attack.	Clear	1 Year
Prime Coat	Louvers or architectural products shall be cleaned, pre-treated and receive a prime coat finish suitable for field painting. Aiolite does not recommend prime coat or field painting of materials.		n/a
Mill	Materials may be supplied in natural aluminum or galvanized steel finish when normal weathering is acceptable and there is no concern for color or color change.		n/a

Finishes meet or exceed AAMA 2605, AAMA 2604, and AAMA 2603 requirements. Please consult www.airolite.com for complete information on standard and extended paint warranties. Paint finish warranties are not applicable to steel products.



P.O. Box 410, 525 Western Road, Schofield, WI 54476-0410 USA
715.841.8757 • fax 715.841.8773 • www.airolite.com

Submittal Linear Bar February 2020
Copyright ©2020 The Aiolite Company, LLC

The Aiolite Company, LLC reserves the right to make product changes.