

ARCHITECTURAL SUN CONTROL

Sun Control Type	TSC4
Blade Type	Rectangular Tube
Blade Material	Extruded Aluminum (Alloy 6063-T5)
Blade Material Thickness	0.125 in. (3.18 mm)
Blade Dimension	1 x 4 in. (25.4 x 101.6 mm)
Outrigger Material	Aluminum Plate (Alloy 6061-T6)
Outrigger Material Thickness	0.250 in. (6.35 mm)
Standard Fascia	4 in. (101.6 mm) Round Tube
Optional Fascia	Rectangular Tube or Channel
Optional Mounting	Extruded Aluminum Tee
Construction	Mechanically Fastened, Welded Optional

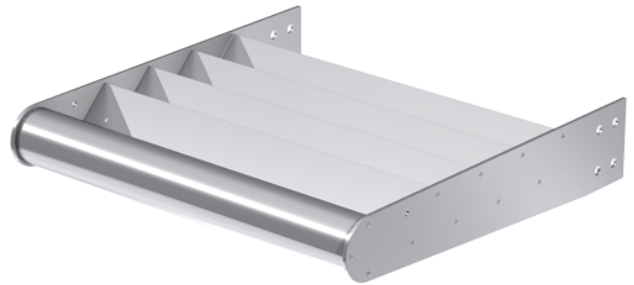

RECOMMENDED SPECIFICATION

Airolite TSC4 Sun Controls are produced from extruded aluminum 1 x 4" (25.4 x 101.6 mm) rectangular tube blades. Outriggers are constructed from a minimum 0.25" (6.35 mm) aluminum plate material. Standard fascia is a 4" (101.6 mm) round tube, but optional fascia may be specified. Optional extruded aluminum mounting tees by Airolite are standard construction. Blade spacing shall be 4.5" (114.3 mm) on center. Sun controls utilize mechanically fastened construction, with welded construction as an option. All materials are available in Airolite's broad array of baked enamel and fluoropolymer finishes for durability and compatibility with adjacent components. Custom color matching is available upon request. Please contact your local Airolite representative or the factory for assistance with the layout and design of support systems when required.

GENERAL

Where indicated on plan drawings or described in schedules, furnish and install Tube Blade Sun Controls as designed and manufactured by The Airolite Company LLC, Schofield, Wisconsin. Sun controls shall be furnished in the configurations represented on the plan drawings in factory assembled sections, installation hardware and finishes as specified and required for a complete installation. Sections shall be finished after assembly.

SUBMITTALS

Manufacturer shall submit documentation that illustrates sections and details showing profiles, spacing of components, frames and anchors. When welded construction is required, theoretical calculations prepared by a professional engineer specializing in the application of welding technology demonstrating that each fillet weld joining infill elements and frame members will withstand a minimum of 526 pounds of force in shear shall be submitted. Provide samples of manufacturer's finish and color charts showing the full range of finishes and colors available.

PRODUCTS

Architectural Sun Controls shall be Airolite TSC4 Sun Control as follows:

- Blade Type: Rectangular Tube
- Blade Material: Extruded Aluminum (Alloy 6063-T5)
- Blade Material Thickness: 0.125 in. (3.18 mm)
- Blade Dimension: 1 x 4 in. (25.4 x 101.6 mm)
- Outrigger Material: Aluminum Plate (Alloy 6061-T6)
- Outrigger Material Thickness: 0.250 in. (6.35 mm)
- Standard Fascia: 4 in. (101.6 mm) Round Tube
- Optional Fascia: Rectangular Tube or Channel
- Optional Mounting: Extruded Aluminum Tee
- Construction: Mechanically Fastened, Welded Optional

OPTIONAL WELDED ASSEMBLY

Join sun control components with fillet welds mostly concealed from view, unless the size of the sun control makes screwed connections between sun control sections necessary. Sun control blades shall be joined to each outrigger with fillet welds produced with the Pulsed Gas Metal Arc Welding (GMAW/Mig) process.

STRUCTURAL DESIGN CRITERIA

Manufacturer shall design and furnish all supports required to design load of up to 25 pounds per square foot. The design load includes loads derived from wind, snow (including drift), seismic events and the dead load of the sunshade. Consult factory for higher loading conditions. Maximum section size is 144-inches (3,658 mm) wide x 48-inches (3,048 mm) projection, with standard fascia. Maximum section size may vary depending on optional fascia selected. Consult factory for larger sizes. Sun Control members, blades, outriggers, fascia and anchorages shall be demonstrated to withstand the specified wind design load.

See page 2 for complete finish options

SUN CONTROL TYPE TSC4 DETAILS & FINISH OPTIONS

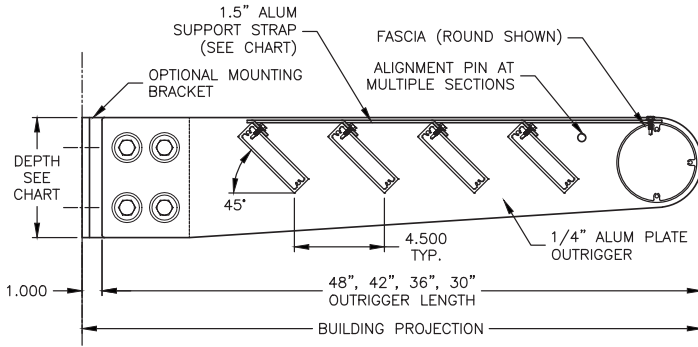

DEPTH = 6.00"	IF FASCIA TYPE = ROUND	SECTION SUPPORT STRAP QTY.
DEPTH = 4.00"	IF FASCIA TYPE = 4" RECT. TUBE	> 48" < 96" 1 - CENTERED
DEPTH = 6.00"	IF FASCIA TYPE = 6" RECT. TUBE	> 96" 2 - EQUAL SPACED
DEPTH = 4.00"	IF FASCIA TYPE = 4" CHANNEL	
DEPTH = 6.00"	IF FASCIA TYPE = 6" CHANNEL	

OPTIONAL FASCIA OUTRIGGER STYLE WILL VARY

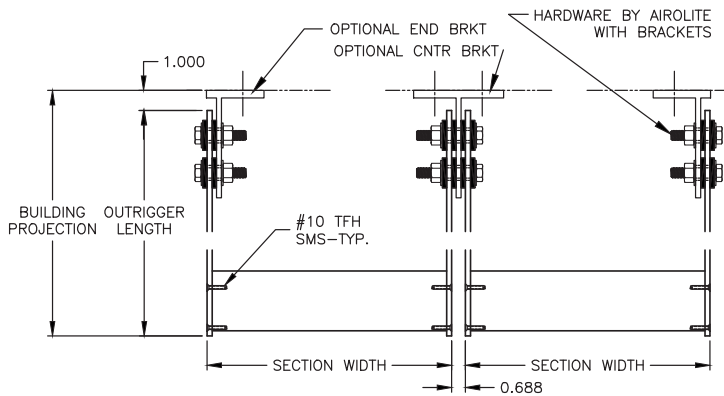
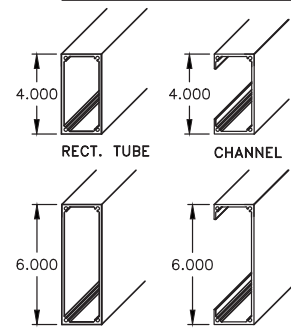

OPTIONAL MOUNTING BRACKETS

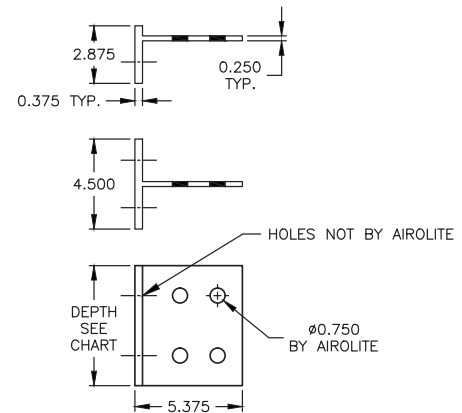

Airolite supplied hardware kits are for 1/4" thick knife plates. Please consult factory for sizes other than 1/4".
 Optional mounting brackets require field drilling for mounting to building structure; these holes are not supplied by Airolite.

FINISHES

Finish Type	Description/Application	Color Selection	Standard Warranty (Aluminum)
AAMA 2605 100% Fluoropolymer (FEVE) 2-Coat 70% Kynar® (PVDF) 3-Coat 70% Kynar® (PVDF) 4-Coat 70% Kynar® (PVDF)	"Best." The premier finish for extruded aluminum. Tough, long-lasting coating has superior color retention and abrasive properties. Resists chalking, fading, chemical abrasion and weathering.	Standard Colors: Any of the 27 standard colors shown can be furnished in 70% or 50% Kynar®, 100% Fluoropolymer or Baked Enamel. Mica Colors: Airolite offers 6 standard Mica colors for 70% Kynar® or 100% Fluoropolymer. Custom Colors: Custom color matching is available. Consult your Airolite representative for cost and/or lead-time implications if a custom color is required.	10 Years (20 Years Optional)
AAMA 2603 Baked Enamel	"Good." Provides good adhesion and resistance to weathering, corrosion and chemical stain.		1 Year
Prime Coat	Louvers or architectural products shall be cleaned, pre-treated and receive a prime coat finish suitable for field painting. Airolite does not recommend prime coat or field painting of materials.		n/a
Mill	Materials may be supplied in natural aluminum or galvanized steel finish when normal weathering is acceptable and there is no concern for color or color change.		n/a

Finishes meet or exceed AAMA 2605, AAMA 2604, and AAMA 2603 requirements. Please consult www.airolite.com for complete information on standard and extended paint warranties. Paint finish warranties are not applicable to steel products.



P.O. Box 410, 525 Western Road, Schofield, WI 54476-0410 USA
 715.841.8757 • fax 715.841.8773 • www.airolite.com

Submittal Airfoil Sun Control TSC4 February 2020
 Copyright ©2020 The Airolite Company, LLC

The Airolite Company, LLC reserves the right to make product changes.