

MOUNTING CLIPS

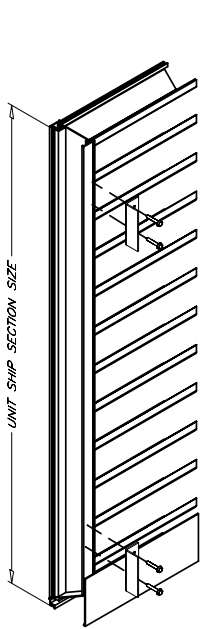

SINGLE SECTION ANCHOR CLIPS INSTALLATION

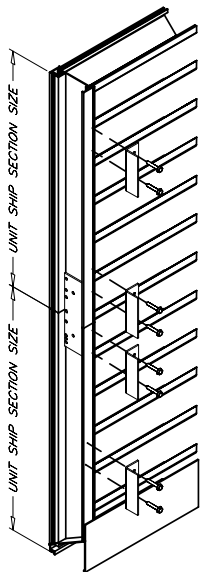

MULTIPLE SECTION HIGH ANCHOR CLIPS INSTALLATION

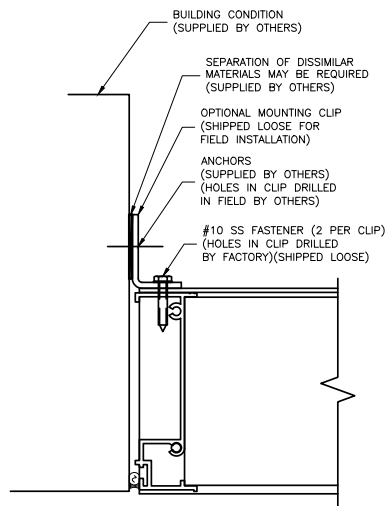

JAMB DETAIL

MATERIAL NOTE:
 ALUMINUM LOUVERS - 1.0X1.5X4.00, .125 ALUM
 GALVANIZED LOUVERS - 1.0X1.5X2.00, 16 GA GALV
 STAINLESS STEEL LOUVERS - 1.0X1.5X2.00, 16 GA SS

SINGLE SECTIONS WIDE, SINGLE SECTION HIGH

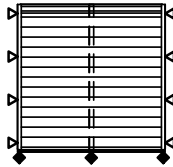

MULTIPLE SECTIONS WIDE, SINGLE SECTION HIGH (UNSUPPORTED MULLION)

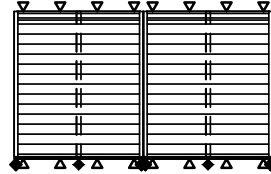

SINGLE SECTIONS WIDE, MULTIPLE SECTION HIGH

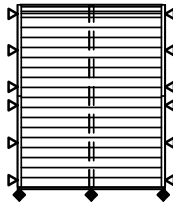

MULTIPLE SECTIONS WIDE, SINGLE SECTION HIGH (SUPPORTED MULLION)

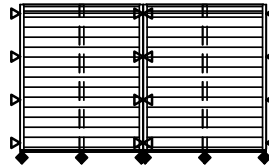

MULTIPLE SECTIONS WIDE, MULTIPLE SECTION HIGH

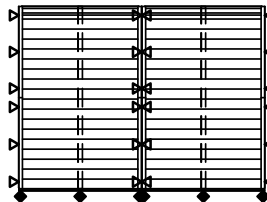

ANCHOR LOCATIONS
 3.00" MAX. OFF EDGE OF EACH SECTION
 18.00" MAX. O/C CLIP SPACING

- ▲ = RECOMMENDED ANCHOR LOCATION
- ◆ = RECOMMENDED DEAD LOAD SHIM

AS A RESULT OF OUR COMMITMENT TO CONTINUOUS IMPROVEMENT, THIS SUPPLIER RESERVES THE RIGHT TO CHANGE SPECIFICATIONS WITHOUT NOTICE

