

## Installation, Operation and Maintenance Manual

Please read and save these instructions for future reference. Read carefully before attempting to assemble, install, operate or maintain the product described. Protect yourself and others by observing all safety information. Failure to comply with these instructions will result in voiding of the product warranty and may result in personal injury and/or property damage.

### Table of Contents

---

47155 – Vektor-CH, Vektor-CD and Vektor-CS . . . . .	2
1016014 – Vektor-C Series Fastener Kit Windband to Nozzle . . . . .	20
1016015 – Vektor-C Series Fastener Kit Nozzle to Stack and Stack to Fan . . . . .	21

## Installation, Operation and Maintenance Manual

Please read and save these instructions for future reference. Read carefully before attempting to assemble, install, operate or maintain the product described. Protect yourself and others by observing all safety information. Failure to comply with these instructions will result in voiding of the product warranty and may result in personal injury and/or property damage.

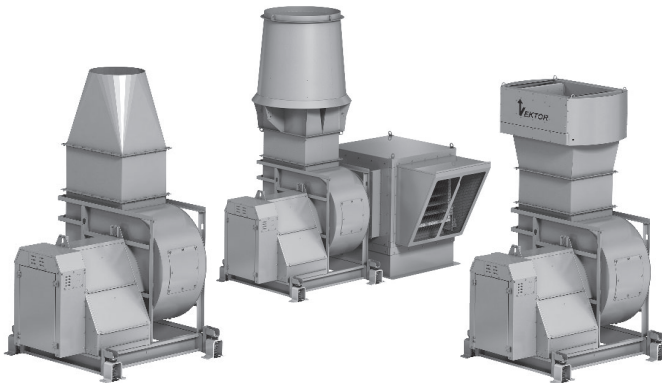

### Table of Contents

Receiving / Unpacking / Handling / Storage . . . . .	3
Inspection and Maintenance during Storage . . . . .	3
Removing from Storage . . . . .	4
General Information	
Unit and System Identification Tags . . . . .	4
Pre-Installation Information / Electrical Disconnects .	4
Moving Parts / Guards / Fan Access Doors . . . . .	5
Air Pressure and Suction. . . . .	5
Standard Fan Configurations . . . . .	5
Vektor-C Series Arrangements . . . . .	5
Roof Curb and Mounting Details . . . . .	6
Bases - Foundation and Isolation. . . . .	6
Plenum Assembly . . . . .	7
Duct Connections to the Bypass Air Plenum . . . . .	8
Fans - Rigging, Lifting and Installation . . . . .	8-9
Flex Connection Installation . . . . .	10
Plenum/Fan Drainage Piping / Trap Detail (by others)	10
Electrical Connections . . . . .	11
Field Coating Touch-Up Procedure. . . . .	12
Unit Start-Up. . . . .	13
Routine Maintenance and Operation	
Fan Operation / V-Belt Drives / Motors . . . . .	14
Bearings . . . . .	15
Vektor-CS Nozzle Bearings. . . . .	15
Service	
V-Belt Drives and Installation . . . . .	15
Bearing Replacement . . . . .	15
Radial Gap, Overlap and Wheel Alignment. . . . .	16
Flexible Couplings (Arr. 8 Only). . . . .	16
Troubleshooting. . . . .	17
CS Nozzle Parts and Assembly . . . . .	18
Maintenance Log. . . . .	19
Our Commitment. . . . .	19

### General Safety Information

Only qualified personnel should install this fan system. Personnel should have a clear understanding of these instructions and should be aware of general safety precautions. Improper installation can result in electric shock, possible injury due to coming in contact with moving parts, as well as other potential hazards. Other considerations may be required if high winds or seismic activity are present. If more information is needed, contact a licensed professional engineer before moving forward.

1. Follow all local electrical and safety codes, as well as the National Electrical Code (NEC), the National Fire Protection Agency (NFPA), where applicable. Follow the Canadian Electrical Code (CEC) in Canada.
2. The rotation of the wheel is critical. It must be free to rotate without striking or rubbing any stationary objects.
3. Motor must be securely and adequately grounded.
4. Do not spin fan wheel faster than maximum cataloged fan rpm. Adjustments to fan speed significantly affects motor load. If the fan RPM is changed, the motor current should be checked to make sure it is not exceeding the motor nameplate amps.
5. Do not allow the power cable to kink or come in contact with oil, grease, hot surfaces or chemicals. Replace cord immediately if damaged.
6. Verify that the power source is compatible with the equipment.
7. Never open access doors to a duct while the fan is running.

#### DANGER

Always disconnect power before working on or near a fan. Lock and tag the disconnect switch or breaker to prevent accidental power up.

#### CAUTION

When servicing the fan, motor may be hot enough to cause pain or injury. Allow motor to cool before servicing.

#### CAUTION

Precaution should be taken in explosive atmospheres.

## Receiving

Greenheck model Vektor-CH, Vektor-CD and Vektor-CS fans are thoroughly inspected, test run at the factory, and shipped on a skid or packaged to minimize damage during shipment. The transportation carrier has the responsibility of delivering all items in their original condition as received from Greenheck. The individual receiving the equipment is responsible for inspecting the unit for obvious or hidden damage and recording any damage on the bill of lading before acceptance of the equipment. All claims, if necessary, shall be filed with the final carrier.

## Unpacking

Verify that all required parts and the correct quantity of each item have been received, including accessory kit containing gasketing, etc. If any items are missing, report shortages to your local representative to arrange for obtaining missing parts. Sometimes it is not possible that all items for the unit be shipped together due to availability of transportation and truck space. Confirmation of shipment(s) must be limited to only items on the bill of lading.

## Handling

The Vektor-CH, Vektor-CD or Vektor-CS laboratory exhaust system is shipped in subassembly sections for easy rigging and installation. Depending on the fan size, the sections can include: Blower Assembly, Stack and Discharge Nozzle.

The Vektor-CH, Vektor-CD and Vektor-CS are designed to be self-supporting and standing (without the use of guy wires) when assembled per the instructions provided within this manual. If additional components are supplied, contact factory or reference submittal if additional supports or guy wires are required. All subassembly sections have lifting lugs as shown.

## Storage

Fans are protected against damage during shipment. If the unit cannot be installed and operated immediately, precautions need to be taken to prevent deterioration of the unit during storage. The user assumes responsibility of the fan and accessories while in storage. The manufacturer will not be responsible for damage during storage. These suggestions are provided solely as a convenience to the user.

**Indoor** - The ideal environment for the storage of fans and accessories is indoors, above grade, in a low humidity atmosphere which is sealed to prevent the entry of blowing dust, rain, or snow. Temperatures should be evenly maintained between 30° and 110°F. (-1°C and 43°C). Wide temperature swings may cause condensation and “sweating” of metal parts. All accessories must be stored indoors in a clean, dry atmosphere.

Remove any accumulations of dirt, water, ice or snow and wipe dry before moving to indoor storage. To avoid “sweating” of metal parts, allow cold parts to reach room temperature. To dry parts and packages use a portable electric heater to get rid of any moisture build up. Leave coverings loose to permit air circulation and to allow for periodic inspection.

The unit should be stored at least 3½ in. (89 mm) off the floor on wooden blocks covered with moisture proof paper or polyethylene sheathing. Aisles between parts and along all walls should be provided to permit air circulation and space for inspection.

**Outdoor** - Fans designed for outdoor applications may be stored outdoors, if absolutely necessary. Roads or aisles for portable cranes and hauling equipment are needed.

The fan should be placed on a level surface to prevent water from leaking into the fan. The fan should be elevated on an adequate number of wooden blocks so that it is above water and snow levels and has enough blocking to prevent it from settling into soft ground. Locate parts far enough apart to permit air circulation, sunlight, and space for periodic inspection. To minimize water accumulation, place all fan parts on blocking supports so that rain water will run off.

Do not cover parts with plastic film or tarps as these cause condensation of moisture from the air passing through heating and cooling cycles.

Fan wheels should be blocked to prevent spinning caused by strong winds.

## Inspection and Maintenance during Storage

While in storage, inspect fans once per month. Keep a record of inspection and maintenance performed; record on pages 18 and 19.

If moisture or dirt accumulations are found on parts, the source should be located and eliminated. At each inspection, rotate the wheel by hand ten to fifteen revolutions to distribute lubricant on motor and bearings. Bearings should be lubricated at three month intervals. The quantity of grease should be per the lubrication label.

If paint deterioration begins, consideration should be given to touch-up or repainting. Fans with special coatings may require special techniques for touch-up or repair.

Machined parts coated with rust preventive coating should be restored to good condition promptly if signs of rust occur. Immediately remove the original rust preventive coating with petroleum solvent and clean with lint-free cloths. Polish any remaining rust from surface with crocus cloth or fine emery paper and oil. Do not destroy the continuity of the surfaces. Wipe clean thoroughly with Tectyl® 506 (Ashland Inc.) or the equivalent. For hard to reach internal surfaces or for occasional use, consider using Tectyl® 511M Rust Preventive or WD-40® or the equivalent.

**Removing from Storage** - As fans are removed from storage to be installed in their final location, they should be protected and maintained in a similar fashion, until the fan equipment goes into operation.

Prior to assembly and installation of the Vektor fan and system components, inspect the fan assembly to make sure it is in working order.

1. Check all fasteners, set screws on the fan, wheel, bearings, drive, motor base and accessories for tightness.
2. Rotate the fan wheel(s) by hand and assure no parts are rubbing. Access to the wheel is obtained through a bolted panel located on the side of the fan housing.
3. Ensure proper wheel settings for radial gap and alignment (see page 15).

## General Information

To ensure a successful installation, the instructions in this manual should be read and adhered to. Failure to comply with proper installation procedures may void the warranty.

### Unit and System Identification Tags

Each fan has a permanently affixed manufacturer's engraved aluminum nameplate containing the model number and individual serial number.

The tag shown is an example of an identification nameplate on the fan. The information provides general details about the fan, as well as containing specific information unique to the unit. When contacting your Greenheck representative with future needs or questions, please have the information on this label available. Tags are mounted in an area which is clearly visible, usually on the side of the fan cabinet.



Vektor fan systems may arrive in component pieces due to shipping restrictions. Individual components of a system have matching identification tags which should be used to identify and assemble the complete system. Assembling systems with different identification tags can cause reductions in the fan(s) performance.

Prior to fully assembling and installing the Vektor-CH, Vektor-CD or Vektor-CS fans, inspect bypass air plenums and the fan assembly to make sure they are in working order.

### Pre-Installation Information

Before installation, it is important to be certain the mounting surface will bear the operating weight of the unit. For proper unit operation, it is also important that it be operated in a completely level position.

For further details on safety practices involving industrial and commercial fans, please refer to AMCA Publication 410.

### Electrical Disconnects

All fan motors should have disconnects located in close visual proximity to turn off electrical service. Service disconnects shall be locked-out when maintenance is being performed.

## Moving Parts

All moving parts must have guards to protect personnel. Refer to local codes for requirements as to the number, type and design. Fully secure fan wheel before performing any maintenance. The fan wheel may start “free wheeling” even if all electrical power has been disconnected. Before the initial start-up or any restart, check the following items to make sure that they are installed and secure.

- Do not spin fan wheel faster than the maximum cataloged fan rpm.
- Adjustments to fan speed significantly affects motor load. If the fan RPM is changed, the motor current should be checked to make sure it is not exceeding the motor nameplate amps.

## Guards (Motor Cover, Weatherhoods, Actuator Cover)

Do not operate fans without proper protective devices in place. Failure to do so may result in serious bodily injury and property damage. Check local codes to ensure compliance for all protective devices.

## Fan Access Doors

Before opening access doors, ensure the fan wheel has stopped moving and that the wheel has been secured from being able to rotate. Do not operate fan without access door in its fully closed position.

## Air Pressure and Suction

In addition to the usual hazards associated with rotating machinery, fans also create a dangerous suction at the inlet. Special caution needs to be used when moving around a fan, whether it is in operation or not. Before start-up, make sure the inlet area is clear of personnel and loose objects.

## Standard Fan Configurations

The following illustration identifies a typical configuration of the Vektor-C Series system. Greenheck also supplies custom configurations. Your system may not be depicted in the drawing shown. Refer to submittal drawing.

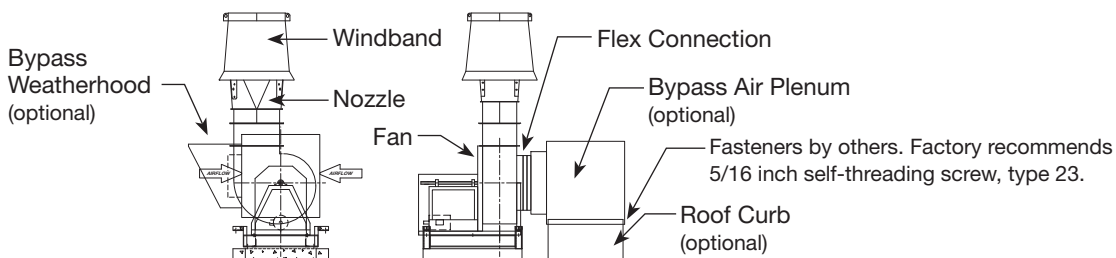

Shown with a Vektor-CD high plume dilution nozzle and windband. Layout applies to all models.

## Vektor-C Series Arrangements

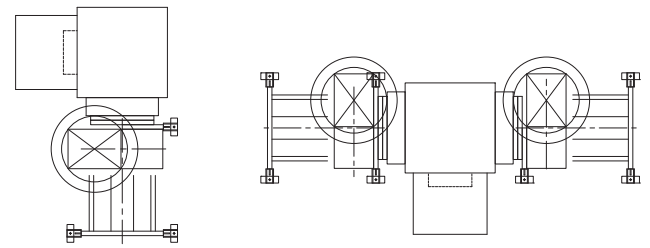

Single Fan System

Opposed Fan System

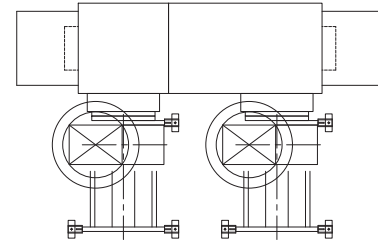

Two Fan System

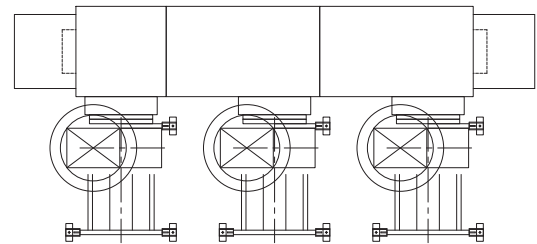

Three Fan System

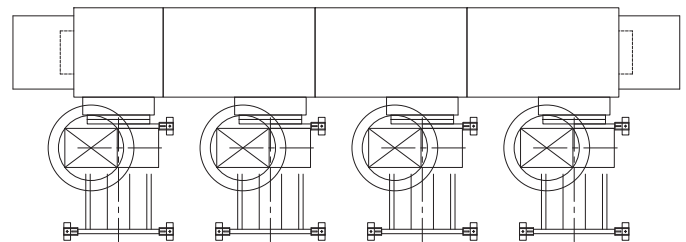

Four Fan System

## Roof Curb and Mounting Details

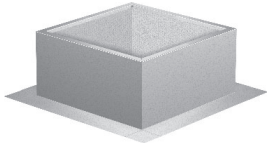

These figures illustrate three common methods used to install Vektor systems. Methods used to attach a Vektor unit are dependent on local codes, roof construction design and roof construction materials. Consult an architect or structural engineer for proper means of attachment.

construction materials. Consult an architect or structural engineer for proper means of attachment.

### NOTE

Steel, concrete or wood roof support is per structural engineer and in accordance with load requirements and applicable building codes.

### Steel

Continuous weld or stitch weld.  
Minimum 6 inch (152.4 mm) stitch weld by 3.25 inch (82.5 mm) spacing minimum.  
Minimum 6 inch (152.4 mm) weld on each corner.

OR

Install 5/16 inch (7.9375 mm) 24 Dril-Flex® Self-Drilling Tapping Screws. 3/16 inch (4.7625 mm) minimum thread engagement into A36 steel, centered in flange.  
4.5 inch (114.3 mm) spacing  
5/8 inch (15.875 mm) minimum edge distance  
ALL HARDWARE BY OTHERS

STEEL STRUCTURAL SUPPORT  
(BY OTHERS, SEE NOTE ABOVE)

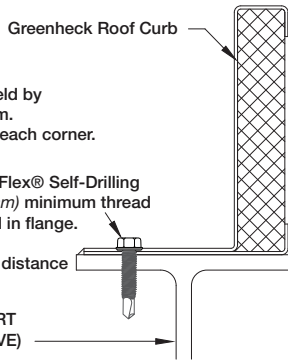

### Concrete

Install 3/8 inch (9.525 mm) SS power wedge bolts  
2.5 inch (63.5 mm) maximum spacing from curb corners  
4.5 inch (114.3 mm) maximum bolt spacing  
3.5 inch (88.9 mm) minimum embedment  
4.5 inch (114.3 mm) minimum edge distance  
distance centered in flange  
ALL HARDWARE BY OTHERS

CONCRETE STRUCTURAL SUPPORT  
(BY OTHERS, SEE NOTE ABOVE)

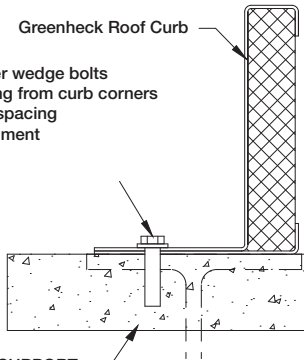

### Wood

Install 3/8 inch (9.525 mm) SS lag or thru-bolt with 1 inch (25.4 mm) O.D. washer  
2.5 inch (63.5 mm) maximum spacing from curb corners  
4.5 inch (114.3 mm) maximum bolt spacing  
3.5 inch (88.9 mm) minimum tread engagement, not including tapered tip  
2 inch (50.8 mm) minimum edge distance, centered in flange  
Pre-drill holes 40-60% of lag diameter  
ALL HARDWARE BY OTHERS

WOODEN STRUCTURAL SUPPORT  
(BY OTHERS, SEE NOTE ABOVE)

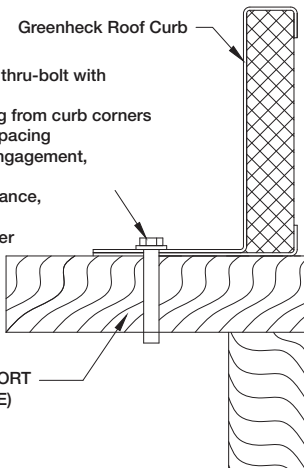

## Bases – Foundation and Isolation

Critical to every fan installation is a strong, level foundation. A reinforced poured concrete pad with a structural steel base or inertia base provides an excellent foundation. Structural bases must be sturdy enough, with welded construction, to prevent flexing and vibration.



To eliminate vibration and noise from being transferred to the building, vibration isolators should be used. The fan is mounted directly on the isolation base and must be supported for the entire length of the fan base angle (Refer to the installation manual for structural bases if the base was supplied by Greenheck). Isolators are installed between the isolation base and the foundation.

After the fan, isolation base and isolators are installed, the entire assembly must be leveled. Position the level on the isolation base, not the fan shaft, for proper leveling. Additionally, the motor and fan shafts must be level and parallel relative to each other for proper alignment.

### NOTE

When provided with isolators, Greenheck supplies information identifying isolator location and separate installation instructions.

## Plenum Assembly

If the plenum is shipped disassembled, the plenum sections can be assembled together into one single piece before lifting onto the roof and then fitted on the roof curb / support structure, or each section can be placed on individually. The method used would be dependent on the lifting capacity for the equipment on-site. If moving each piece separately onto the roof curb or support structure, each section should be joined to its mating part before moving another section into place.

### Multiple fan systems

When looking at the individual shipping assemblies, you will notice that each plenum section is missing at least one side panel. These areas are the locations where the sections are to be joined together. Please refer to the submittal drawing for the orientation of any Bypass Air Plenum (BAP) dampers or air inlet locations.

### Putting the plenum together

After identifying the plenum sections orientation, one of the two mating sections has weld nuts on the inside of the plenum. The assembly hardware (stainless steel bolts) required to join the sections is located here for shipping purposes. These bolts should be removed and set-aside prior to placing the mating sections together. The bolts are located every 6 to 10 inches to provide the best seal between the mating sections.

Before moving the sections into position, gasketing must be installed to seal the plenum sections against leakage. This silicone gasketing is supplied with the fans and only needs to be applied to one of the two mating plenum sections. The bands or strips of gasketing should be attached around the perimeter of the joining face and with an additional strip making a triangular area in each corner.

After the gasketing has been attached and the hardware has been removed, place the two mating sections together. The stainless steel bolts, which were set aside earlier, are now run first through the holes of the plenum section without the weld nuts and tighten into the weld nuts on the other plenum section.

An additional side (or access) panel may need to be removed in order to gain access to the inside of the plenum assembly. The bolts should be tightened in an even and consistent manner as to pull the two sections together and compress the gasketing.

### After the plenum is assembled

Use all provided hardware to tighten and join the mating sections together. Any side panels removed to gain access to the interior of the plenum should be reattached. The assembled plenum has holes in the curb cap to fasten the plenum to the already installed roof curb.

## Modular Plenum Isometric View

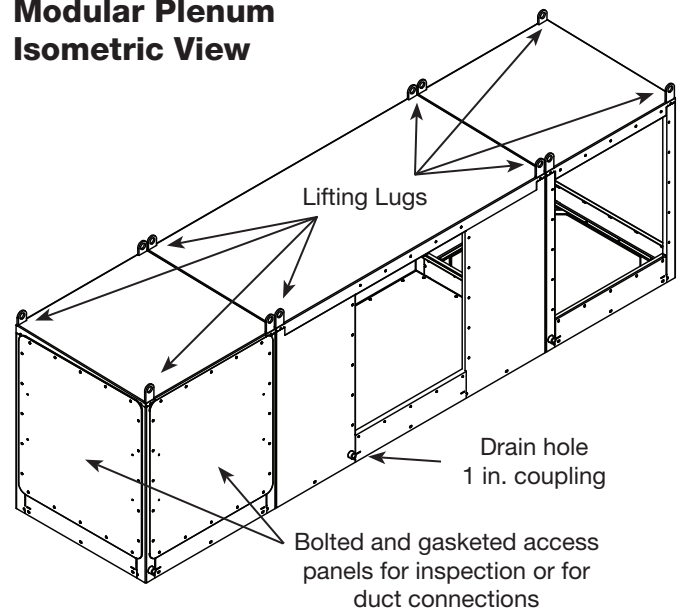

## Rigging Instructions

1. Use standard lifting and rigging practices.
2. All lifting lugs on each component must be utilized at the same time.
3. Plenum, blower, and windband are to be kept level during installation.

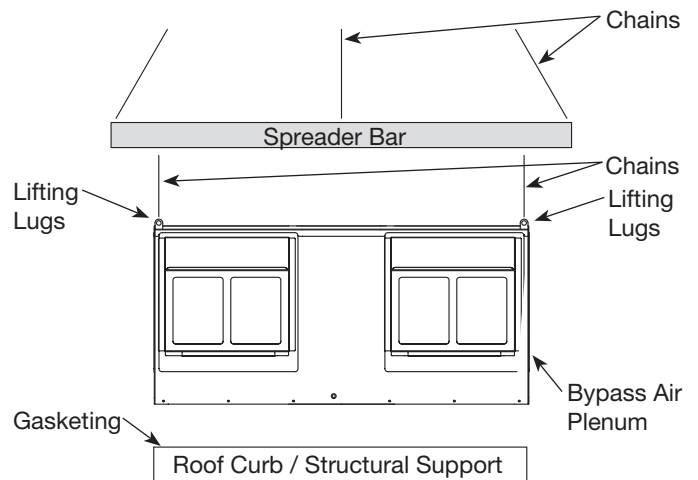

## Duct Connections to the Bypass Air Plenum (BAP)

Connecting primary inlet exhaust air ducts is allowed through the roof curb or through one or more of the side access panels. To reduce the potential for system effects in the plenum, the duct connection should be sized to have no more than a maximum air velocity of 1500 fpm (76 m/s) when entering. When attaching ductwork to the plenum, care should be taken to ensure a tight fit and proper seal to prevent leakage from the contaminated airstream.

### Side Inlet Duct Connections

Ductwork that has a different size than the removable access panel(s) can either have a transition to the plenum's opening size or the access panel can be field modified by cutting an opening to the size of the ductwork.

### Bottom Inlet Duct Connections

Bottom inlet duct connects should be made by attaching the duct to the inside panel edge of the plenum. Ducting to multiple fan plenum may either be split below the roof level and connected to duct drops from the inside the plenum or having the ducting notched for fitting around roof curb and plenum cross support members.

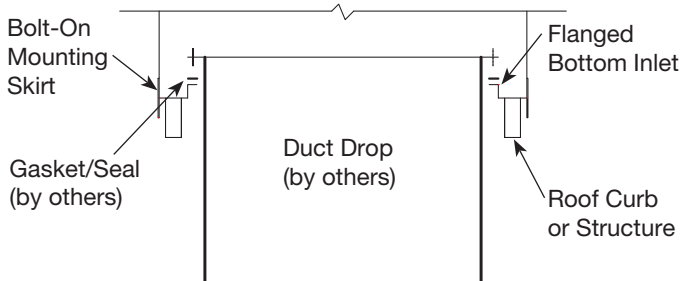

Plenum bottom section view for single fan system. Repeated for multiple fan plenums.

Duct connections are to be sealed from air leakage and water penetration.

## Fans – Rigging, Lifting and Installation

### NOTE

Fans should never be lifted by the shaft, motor, motor cover or accessories.

Components that are shipped separately should be lifted separately due to weight and dimensions.

Fans are to be rigged and moved by the lifting brackets provided or by the skid when a forklift is used. Handle in such a manner as to keep from scratching or chipping the coating. Damaged finish may reduce ability of fan to resist corrosion. Refer to coating touch-up section in this manual for procedure to repair minor scratches.

- Use standard lifting and rigging practices.
- **ALL** lifting lugs (brackets) on each component must be utilized at the same time.
- Fan to be kept level during lifting and installation.

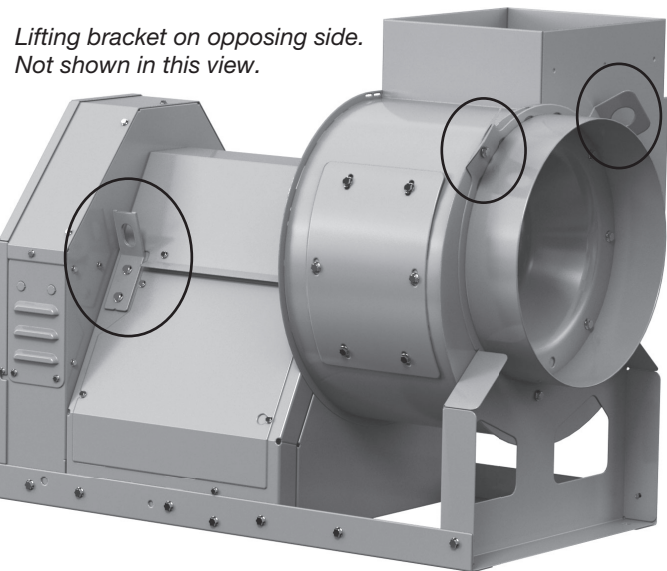



## Fan Stack and Silencer Installation

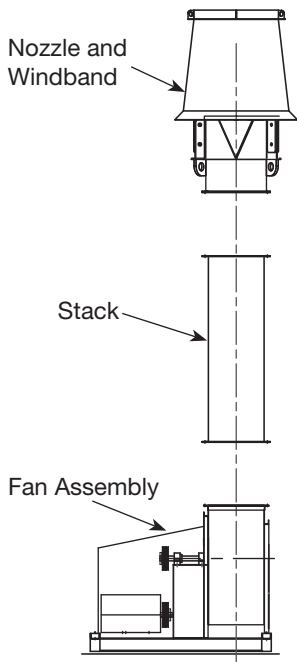

Shown with a high plume dilution nozzle and windband. Information applies to all models.

Systems requiring a stack(s) or silencer have these components installed between fan assembly and nozzle/windband. Systems with both, have the silencer attached to the fan assembly outlet flange with other components installed above.

Supplied gasketing material is placed between any mating section. Use lifting lugs to position each piece into place.

If assembly includes silencer and stack, install the silencer to fan housing, then install the stack to silencer.

Attach components (stack or silencer) to fan housing using 316 stainless steel bolts (provided) through flanges aligning bolt patterns. Use anti-seize gel (provided) to prevent galling/welding of all stainless steel fasteners.

Sizes listed are provided with a stack as standard with fan and nozzle. If only standard height stacks are provided, guy wires are not required unless specified by design engineer. Refer to approved submittal for use of guy wires.

Standard Extension Length					
CD Model		CH Model		CS Model	
Unit Size	Extension Lengths	Unit Size	Extension Lengths	Unit Size	Extension Lengths
12	53.00	12	72.00	12	56.50
15	40.50	15	63.50	15	49.50
18	29.00	18	57.25	18	44.75
22	11.50	22	46.00	22	35.50
		24	39.50	24	30.25
		27	32.50	27	24.50
		30	23.75	30	17.25
		33	20.00	33	15.00
		36	11.25		

Dimensions are in inches.

**Greenheck strongly recommends the use of guy wires on any system that incorporates the usage of a stack extension including inline attenuators. Subsequent guy wires are to be designed and installed by others.**

## Nozzle Lifting and Installation

Using the nozzle/windband lifting lugs, place over blower discharge, aligning attachment holes with bolt holes in blower housing. For CH nozzle, temporarily remove four (4) corner bolts and use connection holes as lifting points. Replace joining bolts after nozzle section is secured. Attach nozzle to blower discharge using moly-coated 316 stainless steel bolts and nuts provided through the flange.



CS Nozzle

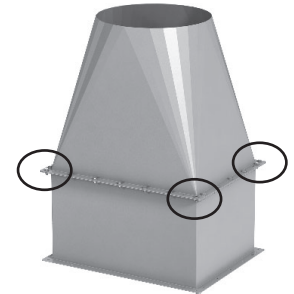

CH Nozzle



CD Nozzle / Windband

Lifting brackets on opposing side. Not shown in all views.

## Guy Wire Locations

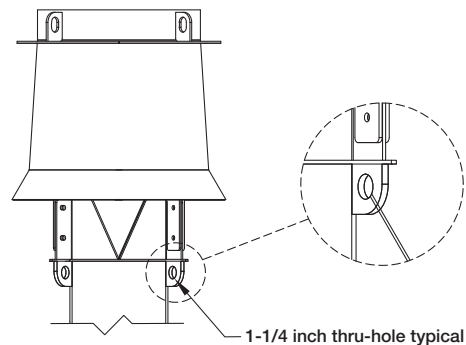

### NOTE

Guy wires to be supplied by others. Fastening to building structure to be provided and engineered by others.

If your fan requires additional stack extensions, (refer to Standard Extension Length table on this page) or discharge silencers, the use of guy wires is recommended. Vektor-CD connection points are located at flange between stack, fan and nozzle. Guy wire attachment locations for the Vektor-CS and Vektor-CH models are at the flanged connection between the nozzle and fan or nozzle and stack extension. See submittal drawing for guy wire connection locations.

## Flex Connection Installation

Connection between fan inlet and square to round damper transition is made using flex material and stainless steel banding.

If isolation damper or plenum is provided, flex connection can be used in ductwork connection.

### EXPLODED VIEW

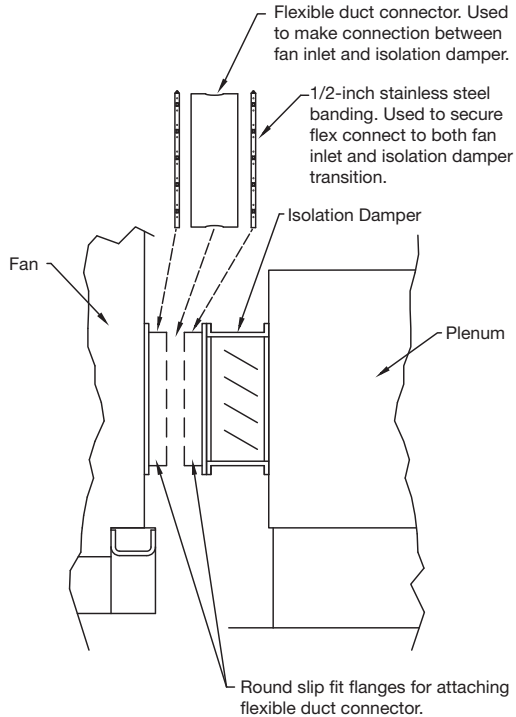

### ASSEMBLED VIEW

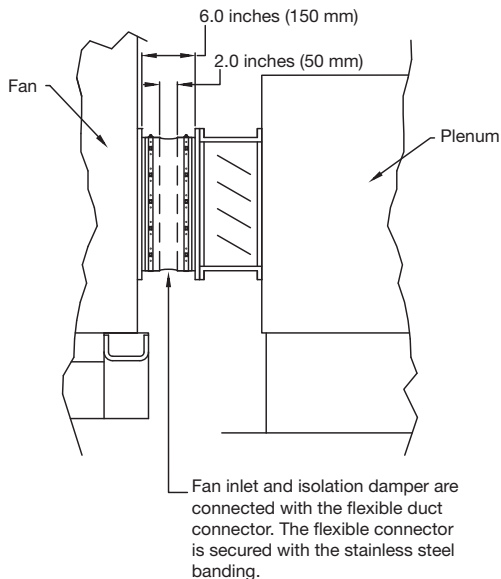

## Plenum/Fan Drainage Piping/Trap Detail (by others)



Fan Drain Connection



Plenum Drain Connection

There is a pipe connection on the fan housing and bypass air plenum. Each drain may need to be connected to a drainage system to ensure proper disposal of any water or condensate that may occur.

- Drain connections are 0.5 inch FNPT and 1.0 inch MNPT
- Installed piping to have a downward angle to allow for drainage
- Fill traps to recommended level before start-up

Note: A conservative method of trap design is to set  $H$  = total static pressure.

- Connect this end to the fan drain and the optional BAP drain.

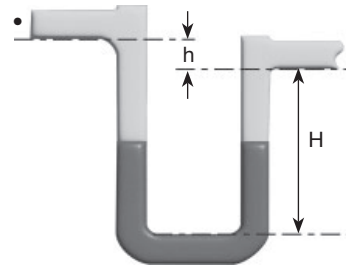

- \* A trap is needed for each fan
- Connect this end to the optional BAP drain.

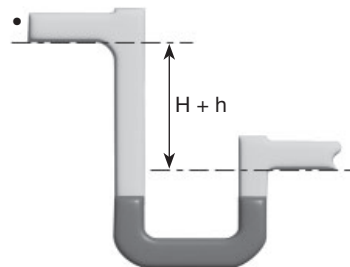

$h = 1 \text{ inch (25.4 mm)}$

$H = 1 \text{ inch for each inch of static pressure}$   
 $(25.4 \text{ mm for each } 250 \text{ Pa of static pressure})$

Check local codes for proper disposal of drain water which has been in contact with the exhaust air.

# Electrical Connections

Before electrical connections are made, the supply voltage, phase and ampere capacity must be checked for compatibility with the fan motor. In addition, the supply wiring must be properly fused and conform to local and national electrical codes. If the unit is supplied with a safety disconnect switch, ensure proper wiring to the fan motor. Be sure the disconnect is switched to the "OFF" position before connecting supply wires. If no disconnect is supplied, ensure the supply wire is not live before connection. Supply wires are then connected to the optional safety disconnect switch (if supplied) or motor.

## Vektor-CH and Vektor-CD Motor Disconnect and Isolation Damper Wiring Diagram

Disconnect is mounted to fan housing. Transformers are mounted to bypass air plenum with damper actuator motors. For systems that ship unassembled because of physical size, this connection at disconnect from transformers must be field-installed. Wires with conduit and fittings are provided pre-connected to transformers.

## Vektor-CH and Vektor-CD Applications with Variable Frequency Drives (VFD)

For Vektor systems with single-point, three-phase wiring per blower, the isolation damper actuator will be powered via a step-down transformer, which is wired to the fan disconnect, as shown in the appropriate diagram.

If fan flow (motor speed) is to be controlled using a variable frequency drive with this wiring, the reduced voltage and frequency supplied to the fan will cause control problems with the isolation damper actuator.

When a project's Vektor control sequence requires the use of a VFD, it is suggested that the control contractor supply the isolation damper actuator voltage — independent of the power supplied to the Vektor fan motor.

### NOTE

For Vektor-CS fans refer to the Vektor Variable Geometry Nozzle (VGN) controls Installation, Operation and Maintenance Manual for electrical wiring and connection information.

Verify starter amperage capacities with those of isolation damper actuator(s).

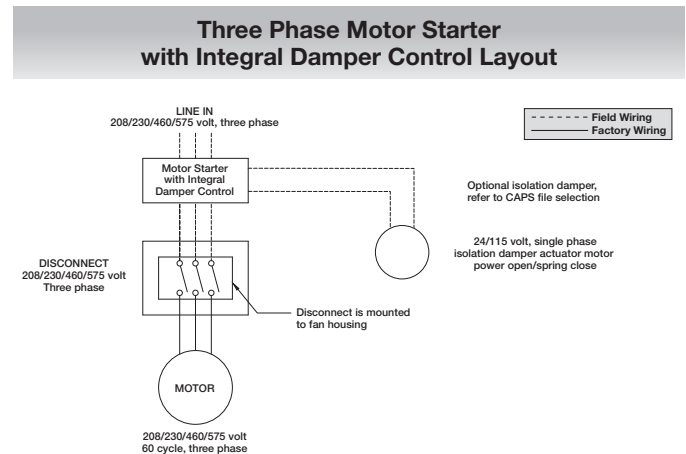
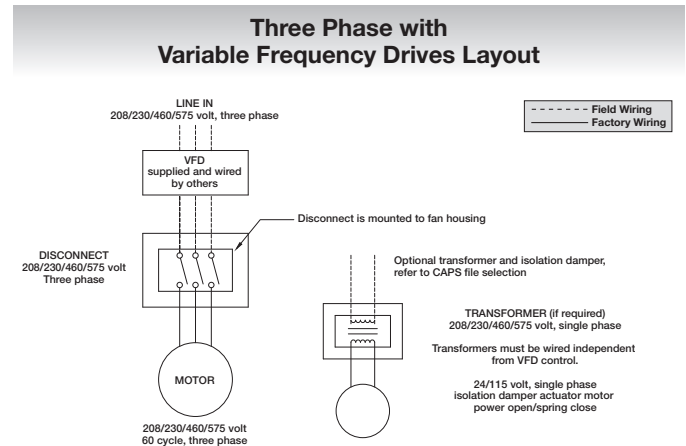
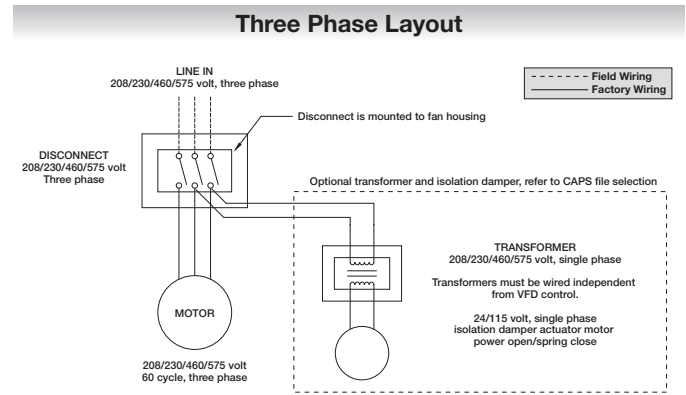

### NOTE

For units supplied or used with a Variable Frequency Drive (VFD), reference the VFD documentation for installation requirements, start-up settings, parameter adjustments and trouble shooting. VFDs provided by Greenheck are factory programmed for basic motor parameters, incoming voltage parameters and maximum operating speed (Hz).

Follow NEC and local codes for VFD wiring and installation. If the wire length between the VFD and the controlled motor exceeds 100 ft (30.5 m), DV/DT filters or VFD cabling may be required. Calculations and proper application of DV/DT filters and VFD cabling is by others; failing to do so may result in premature motor failure.

## Field Coating Touch-Up Procedure for Scratched Areas

---

Standard coating and color for the Vektor laboratory exhaust system is Greenheck's LabCoat™, RAL 7023 Concrete Grey. The procedure details the correct method for repairing minor scratches in the coating.

### TOUCH-UP PAINT REPAIR KIT CONTENTS

- One Zinc Clad Aerosol can
- One pint (recoat epoxy primer grey) with one pint (recoat epoxy primer catalyst)
- One quart H.S. Polyurethane
- One Scotch-Brite scratch pad
- Two 1-1/2 inch wide paint brushes
- Four pint-sized empty cans for mixing
- One quart-sized empty can for mixing
- Zinc repair instructions
- MSDS sheets

### NOTE

While Greenheck provides heavy-duty, quality products for marine environments, routine paint touch-ups may be required in coastal regions where salt or marine air could damage the coating on a Vektor product. The severe environment will accelerate the damage from any scratches or chips and it is recommended that those be repaired immediately.

To order additional coating repair kits please reference Greenheck's part number **HAZ2597 RAL 7023 CONCRETE GREY FIELD REPAIR** kit. Please contact factory with your fan's serial number for colors other than our standard RAL 7023 Concrete Grey.

## Unit Start-Up

### WARNING

Disconnect and secure to the "Off" position all electrical power to the fan prior to inspection or servicing. Failure to comply with this safety precaution could result in serious injury or death.

1. Disconnect and lock-out all power switches to fan.
2. Check for bearing alignment and lubrication.
3. Check the V-belt drive for proper alignment and tension (belt drive).
4. Check rigid coupling for proper alignment and connect between motor shaft and fan shaft (direct drive).
5. Check all guarding to ensure that it is securely attached and not interfering with rotating parts.
6. Check operation of isolation and bypass dampers (if supplied) for freedom of movement.
7. Check all electrical connections for proper attachment.
8. Check housing and ductwork, if accessible, for obstructions and foreign material that may damage the fan wheel.
9. Fill drainage piping trap.
10. Check all fasteners, set screws and locking collars on the fan, bearings, drive, motor base and accessories for tightness.
11. Rotate the fan wheel by hand and assure no parts are rubbing.

### Additional steps for initial start-up

1. Check for proper wheel rotation by momentarily energizing the fan. Rotation is always determined by viewing the wheel from the drive side and should correspond to the rotation decal affixed to the unit.

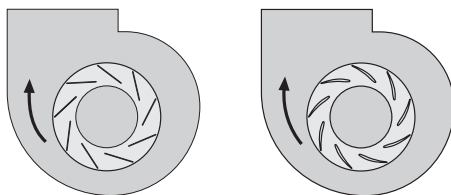

Backward Inclined

Airfoil

**CW Rotation** - always viewed from the drive side.

One of the most frequently encountered problems with Vektor-CH, Vektor-CD and Vektor-CS fans are motors which are wired to run in the wrong direction. This is especially true with 3-phase installations where the motor will run in either direction, depending on how it has been wired. To reverse rotation of a 3-phase motor, interchange any two of the three electrical leads. Single phase motors can be reversed by changing internal connections as described on the motor label or wiring diagram.

2. Fans with multi-speed motors should be checked on low speed during initial start-up.
3. Check for unusual noise, vibration or overheating of bearings. Refer to the "Troubleshooting" section of this manual if a problem develops.
4. Grease may be forced out of the bearing seals during initial start-up. This is a normal self-purging feature.

### Vibration

Excessive vibration is the most frequent problem experienced during initial start-up. Left unchecked, excessive vibration can cause a multitude of problems, including structural and/or component failure.

The most common sources of vibration are listed:

- Wheel Unbalance
- Drive Pulley Misalignment
- Incorrect Belt Tension
- Bearing Misalignment
- Mechanical Looseness
- Faulty Belts
- Drive Component Unbalance
- Poor Inlet/Outlet Conditions
- Foundation Stiffness

Many of these conditions can be discovered by careful observation. Refer to the troubleshooting section of this manual for corrective actions. If observation cannot locate the source of vibration, a qualified technician using vibration analysis equipment should be consulted. If the problem is wheel unbalance, in-place balancing can be done through the access panel located on the side of the fan's housing. Any correction weights added to the wheel should be welded to either the wheel back (single-plane balance) or to the wheel back and wheel cone (two-plane balance).

Greenheck performs a vibration test on all Vektor-CH, Vektor-CD and Vektor-CS fans before shipping. Vibration readings are taken on each bearing in the horizontal, vertical, and axial directions. The allowable maximum vibration is 0.10 in./sec. peak velocity filter-in at the fan rpm per AMCA Standard 204. These vibration signatures are a permanent record of how the fan left the factory and are available upon request.

## Routine Maintenance and Operation

Once the unit has been put into operation, a routine maintenance schedule should be set up to accomplish the following:

1. Lubrication of bearings and motor.
2. Bypass air dampers should be checked for freedom of operation and wear.
3. Wheel, housing, bolts and set screws on the entire fan should be checked for tightness.
4. Any dirt accumulation on the wheel or in the housing should be removed to prevent unbalance and possible damage.
5. Inspect fan impeller and housing looking for fatigue, corrosion, or wear.

### CAUTION

When operating conditions of the fan are to be changed—speed, pressure, temperature, etc.—consult Greenheck to determine if the unit can operate safely at the new conditions.

### Fan Operation

All fans should be run every thirty (30) days, or at least “bumped” every thirty days. It is preferred that each fan is run as this causes all electrical and mechanical components to get up to temperature, displacing any formed condensation, redistributes load on bearings, and redistributes grease in the bearings (motor and shaft bearings).

### V-Belt Drives

V-belt drives must be checked on a regular basis for wear, tension, alignment and dirt accumulation. Premature or frequent belt failures can be caused by improper belt tension (either too loose or too tight) or misaligned sheaves. Abnormally high belt tension or drive misalignment will cause excessive bearing loads and may result in failure of the fan and/or motor bearings. Conversely, loose belts will cause squealing on start-up, excessive belt flutter, slippage and overheated sheaves. Either excessively loose or tight belts may cause fan vibration.

When replacing V-belts on multiple groove drives all belts should be changed to provide uniform drive loading. Use a set of matched belts whenever possible. Do not pry belts on or off the sheave. Loosen belt tension until belts can be removed by simply lifting the belts off the sheaves. After replacing belts, ensure that slack in each belt is on the same side of the drive. Belt dressing should never be used.

Do not install new belts on worn sheaves. If the sheaves have grooves worn in them, they must be replaced before new belts are installed.

The proper tension for operating a V-belt drive is the lowest tension at which the belts will not slip at peak load conditions. Belts are adjusted by raising or lowering the motor pivot plate.

For initial tensioning, the proper belt deflection halfway between sheave centers is  $\frac{1}{64}$  inch for each inch of belt span. For example, if the belt span is 64 inches, the belt deflection should be 1 inch using moderate thumb pressure at mid-point of the drive. Check belt tension two times during the first 24 hours of operation and periodically thereafter.

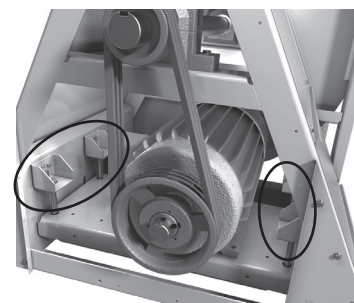

**Motor pivot plate adjustment (four locations)**

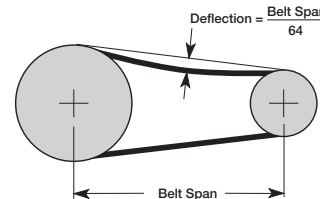

### Motors

Motor maintenance is generally limited to cleaning and lubrication. Cleaning should be limited to exterior surfaces only. Removing dust and grease buildup on the motor housing assists proper motor cooling. Never wash-down motor with high pressure spray.

Greasing of motors is only intended when fittings are provided. Many fractional motors are permanently lubricated for life and require no further lubrication. Motors supplied with grease fittings should be greased in accordance with the manufacturer's recommendations. When motor temperature does not exceed 104°F (40°C), the grease should be replaced after 2000 hours of running time.

Direct drive systems have extended grease lines to lubricate the motor without removal of any guarding.

### NOTE

Motors for direct drive arrangement 4 models have 12 month lubrication intervals. The wheel is attached to the motor shaft on an arrangement 4 fan.

## Bearings

The bearings for Greenheck fans are carefully selected to match the maximum load and operating conditions of the specific class, arrangement, and fan size. The instructions provided in this manual and those provided by the bearing manufacturer will minimize any bearing problems. Bearings are the most critical moving part of the fan, therefore, special care is required when mounting them on the unit and maintaining them.

Never mix greases made with different bases. This will cause a breakdown of the grease and possible failure of the bearing. For specific information, contact the factory representative or the fan system submittals.

Recommended Bearing Lubrication Schedule Relubrication Schedule in Months* Synthetic Grease								
Fan RPM	Bearing Bore (inches)							
	1/2 - 1	1 1/8 - 1 1/2	1 3/8 - 1 7/8	1 5/16 - 2 1/16	2 7/16 - 3	3 3/16 - 3 1/2	3 15/16 - 4 1/2	4 15/16 - 5 1/2
To 250	12	12	12	12	12	12	12	12
500	12	12	12	12	12	12	12	12
750	12	12	12	12	12	12	10	7
1000	12	12	12	12	12	9	6	4
1250	12	12	12	12	9	6	4	2
1500	12	12	12	10	7	4	2	
2000	12	10	8	6	3	1.5	.5	
2500	12	7	5	4	1	.5		
3000	12	5	3	2	.5			
3500	12	3	2	.75				
4000	12	2	.5					
5000	12	1						
Number of shots**	4	8	8	10	16	25	41	57

\* Lubrication interval is based on 12 hour day operation and maximum 160°F housing temperature. For 24 hour per day operation, the interval should be cut in half.

\*\* Lubricant should be added with the shaft rotating and until clean grease is seen purging from the bearing. The lubrication interval may be modified based on the condition of the purged grease. If bearing is not visible to observe purged grease, lubricate with number of shots indicated for bore size.

- For conditions including high temperatures, moisture, dirt or excessive vibration, consult the factory for a specific lubrication interval for your application.
- Lubricant should be a high quality lithium complex synthetic grease conforming to NLGI Grade 2. Factory recommends synthetic Mobilith SHC100.
- The use of non-synthetic lubricants will decrease lubrication intervals by approximately three times.
- Storage periods of three months or longer require monthly rotation of the shaft and purging grease prior to storage and start-up.

## Vektor-CS Nozzle Bearings

The bearings for the CS nozzle assembly are permanently lubricated and do not require additional grease.

## Service

### V-Belt Drives

The V-belt drive components, when supplied by Greenheck Fan Corporation, have been carefully selected for this unit's specific operating condition.

#### CAUTION

Changing V-belt drive components could result in unsafe operating conditions which may cause personal injury or failure of these components:

- Fan shaft
- Fan wheel
- Bearings
- V-belt
- Motor

### V-Belt Drive Installation

1. Remove the protective coating from the end of the fan shaft using mineral spirits or another similar solvent. Check to ensure that the shaft is free of nicks and burrs.
2. Slide sheaves on shafts - do not drive sheaves on as this may result in bearing damage.
3. Align fan and motor sheaves with a straight-edge or string and tighten.
4. Place belts over sheaves. Do not pry or force belts, as this could result in damage to the cords in the belts.
5. Adjust the tension until the belts appear snug. Run the unit for a few minutes and allow the belts to "set" properly.
6. With the fan off, adjust the belt tension by moving the motor pivot plate. When in operation, the tight side of the belts should be in a straight line from sheave to sheave with a slight bow on the slack side.

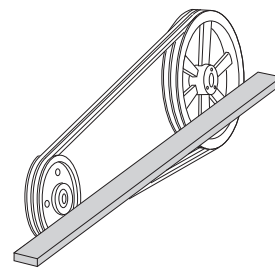

Aligning sheaves with a straight edge

### Bearing Replacement

Both drive bearings are accessible from the ground on all Vektor-C Series fans. Whether direct or belt driven, the bearings, along with other serviceable drive components (belts, motors, sheaves) are accessible by removing the motor cover panel. Please contact Greenheck Fan Corporation for specific instructions on the replacement of the bearings specific for each Vektor-C Series fan. Please include fan identification numbers with the request to ensure that proper instructions are received.

#### NOTE

Bearing replacement could require moving of fan wheel. See Radial Gap, Overlap & Alignment section to realign wheel upon bearing reinstallation.

## Radial Gap, Overlap & Wheel Alignment

Efficient fan performance can be maintained by having the correct radial gap, overlap and wheel alignment. These items should be checked after the fan has been in operation for 24 hours and before start-up after the unit has been serviced.

Radial gap is adjusted by loosening the inlet cone/ring bolts and centering the cone/ring on the wheel. If additional adjustment is required to maintain a constant radial gap, loosening the bearing bolts and centering the wheel is acceptable as a secondary option.

Overlap is adjusted by loosening the wheel hub from the shaft and moving the wheel to the desired position along the shaft. The transition between the inlet cone and wheel should be as shown; there is a smooth feel to the profile when moving from one component to the other. Overlap on double width fans is set by having equal spacing on each side of the wheel.

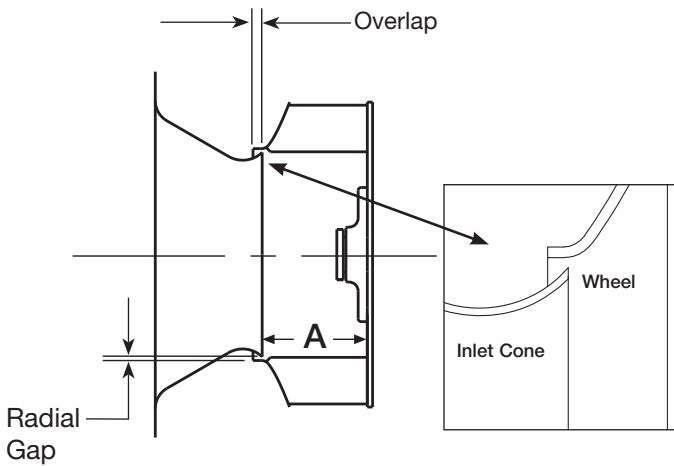

## Flexible Couplings (Arr. 8 Only)

Check for misalignment between the coupling halves. Parallel and angular misalignment and separation gap are illustrated below. Refer to coupling manufacturer's installation instructions for allowable misalignment and separation gap tolerances. When correcting for misalignment using shims, the shims should only be located under the motor. Do not place shims under the shaft bearings.

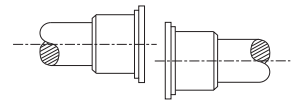

**Parallel Misalignment**

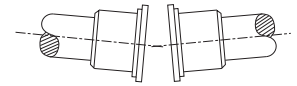

**Angular Misalignment**

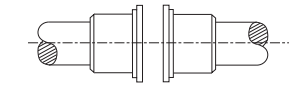

**Separation Gap**

After aligning procedure, check for tightness of all coupling component pieces and ensure that they are clean from dirt and debris.

**Inlet Cone to Backplate Distance**

Unit Size	"A" Dimension (inches)
12	4 ± 1/8
15	5 ± 1/8
18	6 <sup>3</sup> / <sub>8</sub> ± 1/8
22	7 <sup>13</sup> / <sub>16</sub> ± 3/16
24	8 <sup>5</sup> / <sub>8</sub> ± 1/4
27	9 <sup>7</sup> / <sub>16</sub> ± 1/4
30	10 <sup>9</sup> / <sub>16</sub> ± 3/8
33	11 <sup>7</sup> / <sub>16</sub> ± 3/8
36	12 <sup>3</sup> / <sub>4</sub> ± 3/8
40	14 <sup>3</sup> / <sub>16</sub> ± 3/8
44	15 <sup>9</sup> / <sub>16</sub> ± 3/8
49	17 <sup>1</sup> / <sub>8</sub> ± 1/2
54	18 <sup>13</sup> / <sub>16</sub> ± 1/2
60	20 <sup>15</sup> / <sub>16</sub> ± 1/2
66	22 <sup>7</sup> / <sub>8</sub> ± 1/2



## Troubleshooting

Problem	Cause	Corrective Action
Excessive noise	Wheel rubbing inlet	Adjust wheel and/or inlet cone. Tighten wheel hub or bearing collars on shaft.
	V-belt drive	Tighten sheaves on motor/fan shaft. Adjust belt tension. Align sheaves properly (see procedure). Replace worn belts or sheaves.
	Bearings	Replace defective bearing(s). Lubricate bearings. Tighten collars and fasteners.
	Wheel unbalance	Clean all dirt off wheel. Check wheel balance, replace if necessary.
Low CFM	Fan	Check wheel for correct rotation. Check blade position of bypass air plenum (BAP) damper, increase fan speed.*
	Duct system	Higher pressure than design. Filters need replacement.
High CFM	Fan	Decrease fan speed.
	Duct system	Increase BAP damper blade open position. Resize ductwork. Access door, filters, dampers not installed.
Static pressure wrong	Duct system has more or less restriction than anticipated	Change obstructions in system. Use correction factor to adjust for temperature/altitude. Adjust set point used to control BAP damper modulation. Resize ductwork. Clean filters/coils. Change fan speed.*
High horsepower	Fan	Check rotation of wheel. Reduce fan speed.
	Duct system	Resize ductwork. Check proper operation of isolation and bypass dampers. Check filters and access doors.
Fan doesn't operate	Electrical supply	Check fuses/circuit breakers. Check for switches turned off or disconnected. Check for correct supply voltage.
	Drive	Check for broken belts. Tighten loose pulleys.
	Motor	Assure motor is correct horsepower and not tripping overload protector.
Overheated bearing	Lubrication	Check for excessive or insufficient grease in the bearing.
	Mechanical	Replace damaged bearing. Relieve excessive belt tension. Align bearings. Check for bent shaft.
Excessive vibration	Belts	Adjust tightness of belts. Replacement belts should be a matched set.
	System unbalance	Check alignment of shaft, motor and pulleys. Adjustable pitch pulleys with motors over 15 hp are especially prone to unbalance. Check wheel balance, rebalance if necessary.

\* Always check motor amps and compare to nameplate rating. Excessive fan speed may overload the motor and result in motor failure. Do not exceed the maximum cataloged rpm of the fan.

# Vektor-CS Nozzle Parts and Assembly

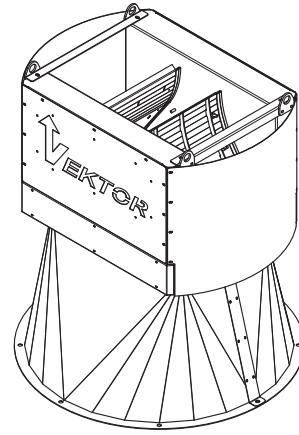
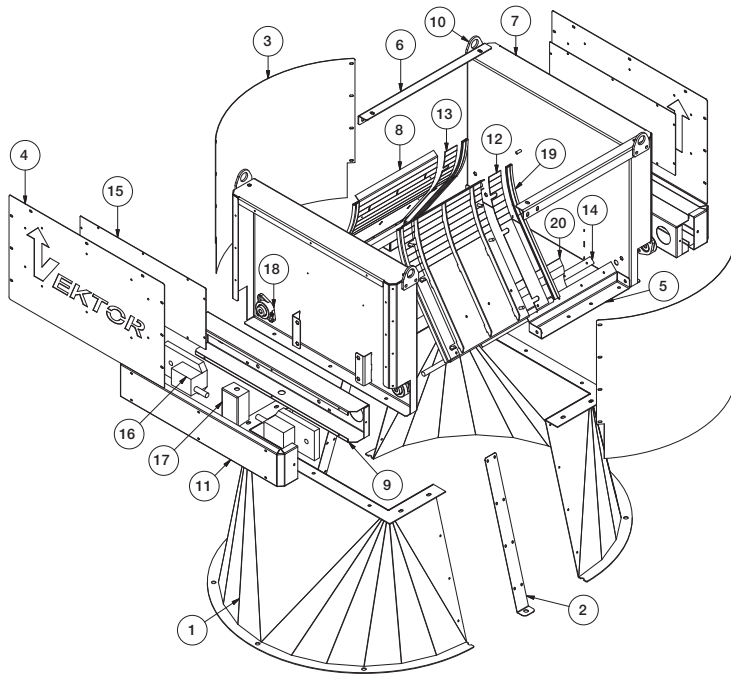

Item	Quantity	Description
1	2	Transition Weld
2	2	Transition side cover
3	2	Wind wrap round
4	2	Wind wrap flat
5	2	Frame bottom bar
6	2	Frame top bar
7	2	Frame weld
8	2	Blade weld
9	2 or 4*	Actuator mount
10	4	Lifting lug
11	2 or 4*	Actuator cover
12	2	Blade seal, right
13	6	Blade seal, left
14	4	Flex backing
15	2	Vektor backing
16	2 or 4*	Actuator
17	1	Electrical box
18	4	Bearing
19	4	Blade seal
20	2	Flex seal

\*Quantity 2 for sizes 12 thru 27  
 Quantity 4 for sizes 30 thru 44

## Maintenance Log

---

Date \_\_\_\_\_ Time \_\_\_\_\_ AM/PM

Notes: \_\_\_\_\_  
\_\_\_\_\_  
\_\_\_\_\_  
\_\_\_\_\_

Date \_\_\_\_\_ Time \_\_\_\_\_ AM/PM

Notes: \_\_\_\_\_  
\_\_\_\_\_  
\_\_\_\_\_  
\_\_\_\_\_

Date \_\_\_\_\_ Time \_\_\_\_\_ AM/PM

Notes: \_\_\_\_\_  
\_\_\_\_\_  
\_\_\_\_\_  
\_\_\_\_\_

Date \_\_\_\_\_ Time \_\_\_\_\_ AM/PM

Notes: \_\_\_\_\_  
\_\_\_\_\_  
\_\_\_\_\_  
\_\_\_\_\_

Date \_\_\_\_\_ Time \_\_\_\_\_ AM/PM

Notes: \_\_\_\_\_  
\_\_\_\_\_  
\_\_\_\_\_  
\_\_\_\_\_

Date \_\_\_\_\_ Time \_\_\_\_\_ AM/PM

Notes: \_\_\_\_\_  
\_\_\_\_\_  
\_\_\_\_\_  
\_\_\_\_\_

Date \_\_\_\_\_ Time \_\_\_\_\_ AM/PM

Notes: \_\_\_\_\_  
\_\_\_\_\_  
\_\_\_\_\_  
\_\_\_\_\_

Date \_\_\_\_\_ Time \_\_\_\_\_ AM/PM

Notes: \_\_\_\_\_  
\_\_\_\_\_  
\_\_\_\_\_  
\_\_\_\_\_

## Our Commitment

---

*As a result of our commitment to continuous improvement, Greenheck reserves the right to change specifications without notice.*

Product warranties can be found online at [Greenheck.com](http://Greenheck.com), either on the specific product page or in the literature section of the website at [Greenheck.com/Resources/Library/Literature](http://Greenheck.com/Resources/Library/Literature).

Greenheck's Vektor-CH and Vektor-CD and Vektor-HS, Vektor-MS and Vektor-CS catalogs provides additional information describing the equipment, fan performance, available accessories, and specification data.

AMCA Publication 410-96, Safety Practices for Users and Installers of Industrial and Commercial Fans, provides additional safety information. This publication can be obtained from AMCA International, Inc. at [www.amca.org](http://www.amca.org).



## Assembly Instructions

**READ THROUGH THESE INSTRUCTIONS PRIOR TO STARTING ASSEMBLY.**

### Document Instructions

Use Document #1016014 with fastener kits 879438 and 879439. These kits are to be used with the Vektor-CD model. The fasteners contained within the kit are to be used to attach the windband to the Vektor-CD nozzle. Use the images located within this document to locate the position of the fasteners on the unit.

### Assembly Instructions

1. See Greenheck Document #471555 (Installation, Operation and Maintenance Manual: Vektor-CD, Vektor-CH and Vektor-CS) for full installation instructions.
2. See image to the right to locate bolt holes. Install moly-coated 316 stainless steel screws (provided) in all holes to secure the windband to the nozzle.

### Tools Required

- Cordless drill (electric or pneumatic)
- 9/16 inch nut setter
- 9/16 inch wrench

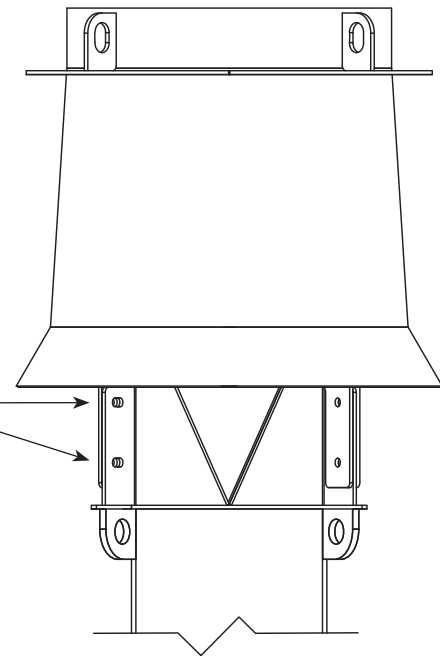
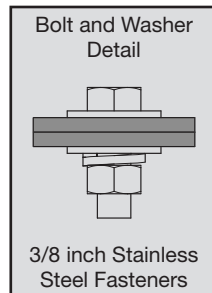

#### FASTENER KIT 879438 – VEKTOR-CD SIZE 12-24

Part Description	Part #	Quantity
CS,HH,.375-16X1.5,SS,316,MOLY	415781	8
NUT,HEX,.375-16,SS,316	415799	8
WSHR,FLAT,.313X.05X.406X.875,SS,316	415800	16
WSHR,LOCK,SPLIT,.375,SS,316	415810	8
Assembly Instructions	1016014	1

#### FASTENER KIT 879439 – VEKTOR-CD SIZE 27-66

Part Description	Part #	Quantity
CS,HH,.375-16X1.5,SS,316,MOLY	415781	12
NUT,HEX,.375-16,SS,316	415799	12
WSHR,FLAT,.313X.05X.406X.875,SS,316	415800	24
WSHR,LOCK,SPLIT,.375,SS,316	415810	12
Assembly Instructions	1016014	1

## Assembly Instructions

**READ THROUGH THESE INSTRUCTIONS PRIOR TO STARTING ASSEMBLY.**

### Document Instructions

Use Document #1016015 with fastener kits 879440, 879441, 879442, 879443 and 879444. These kits are to be used with the Vektor-C series. The fasteners contained within the kit are to be used to attach the nozzle to the fan body, the nozzle to a stack extension, a stack extension to another stack extension, or a stack extension to the fan body. Use the images located within this document to locate the position of the fasteners on the unit.

### Assembly Instructions

1. See Greenheck Document #471555 (Installation, Operation and Maintenance Manual: Vektor-CD, Vektor-CH and Vektor-CS) for full installation instructions.
2. Supplied gasketing material is placed between all mating sections.
3. The fastener kit includes fasteners for one flange. If the fan includes stack extensions, multiple fastener kits will be supplied for each flange.
4. See image to the right to locate bolt holes. Install moly-coated 316 stainless steel screws (provided) in all flange holes.

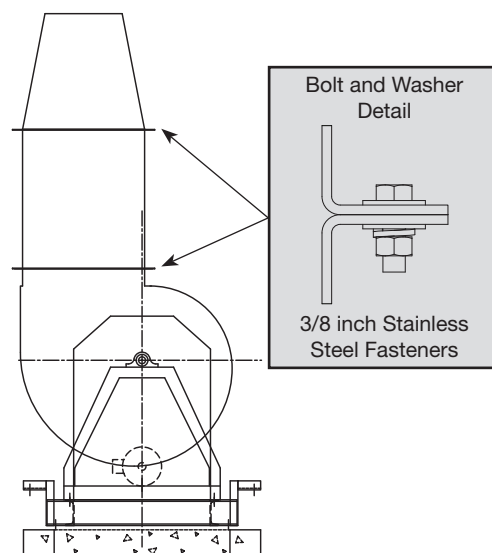

### Tools Required

- Cordless drill (electric or pneumatic)
- 9/16 inch nut setter
- 9/16 inch wrench

### FASTENER KITS - VEKTOR-C SERIES

Vektor-C Fan Size		12-18	22-30	33-40	44-54	60-66
Fastener Kit Part Number		879440	879441	879442	879443	879444
Part Description	Part #	Quantity				
CS,HH, .375-16X1.25,SS,316,MOLY	415780	14	20	28	34	42
NUT,HEX, .375-16,SS,316	415799	14	20	28	34	42
WSHR,FLAT, .313X.05X.406X.875,SS,316	415800	28	40	56	68	84
WSHR,LOCK,SPLIT, .375,SS,316	415810	14	20	28	34	42
Assembly Instructions	1016015	1	1	1	1	1

## Maintenance Log

---

Date \_\_\_\_\_ Time \_\_\_\_\_ AM/PM

Notes: \_\_\_\_\_

\_\_\_\_\_

\_\_\_\_\_

\_\_\_\_\_

Date \_\_\_\_\_ Time \_\_\_\_\_ AM/PM

Notes: \_\_\_\_\_

\_\_\_\_\_

\_\_\_\_\_

\_\_\_\_\_

Date \_\_\_\_\_ Time \_\_\_\_\_ AM/PM

Notes: \_\_\_\_\_

\_\_\_\_\_

\_\_\_\_\_

\_\_\_\_\_

Date \_\_\_\_\_ Time \_\_\_\_\_ AM/PM

Notes: \_\_\_\_\_

\_\_\_\_\_

\_\_\_\_\_

\_\_\_\_\_

Date \_\_\_\_\_ Time \_\_\_\_\_ AM/PM

Notes: \_\_\_\_\_

\_\_\_\_\_

\_\_\_\_\_

\_\_\_\_\_

Date \_\_\_\_\_ Time \_\_\_\_\_ AM/PM

Notes: \_\_\_\_\_

\_\_\_\_\_

\_\_\_\_\_

\_\_\_\_\_

Date \_\_\_\_\_ Time \_\_\_\_\_ AM/PM

Notes: \_\_\_\_\_

\_\_\_\_\_

\_\_\_\_\_

\_\_\_\_\_

Date \_\_\_\_\_ Time \_\_\_\_\_ AM/PM

Notes: \_\_\_\_\_

\_\_\_\_\_

\_\_\_\_\_

\_\_\_\_\_

## Our Commitment

---

*As a result of our commitment to continuous improvement, Greenheck reserves the right to change specifications without notice.*

Product warranties can be found online at [Greenheck.com](http://Greenheck.com), either on the specific product page or in the literature section of the website at [Greenheck.com/Resources/Library/Literature](http://Greenheck.com/Resources/Library/Literature).

AMCA Publication 410-96, Safety Practices for Users and Installers of Industrial and Commercial Fans, provides additional safety information. This publication can be obtained from AMCA International, Inc. at [www.amca.org](http://www.amca.org).

