

Installation, Operation and Maintenance Manual

Please read and save these instructions for future reference. Read carefully before attempting to assemble, install, operate or maintain the product described. Protect yourself and others by observing all safety information. Failure to comply with these instructions will result in voiding of the product warranty and may result in personal injury and/or property damage.

Table of Contents

474118 – Energy Recover System (ERS)	2
1016722 – Vektor-M Series Fastener Kit Bypass Air Plenum to Energy Recovery Plenum.	18

Installation, Operation and Maintenance Manual

Please read and save these instructions for future reference. Read carefully before attempting to assemble, install, operate or maintain the product described. Protect yourself and others by observing all safety information. Failure to comply with these instructions will result in voiding of the product warranty and may result in personal injury and/or property damage.

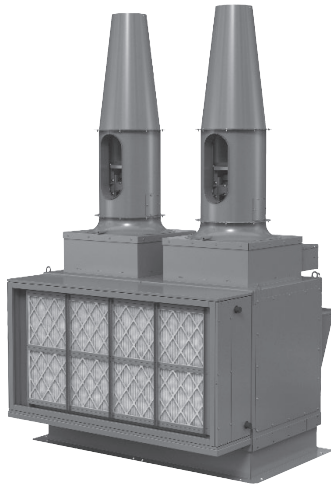

Vektor-M Compact ERS

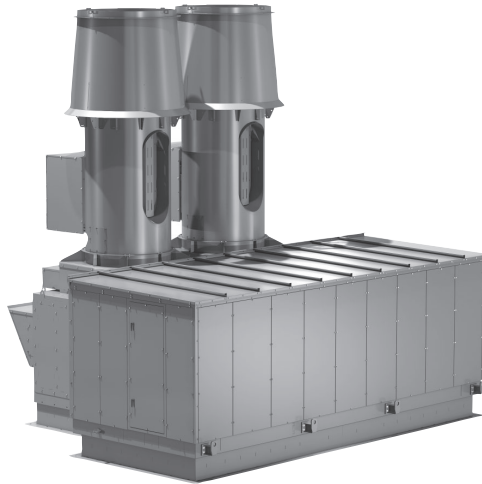

Vektor-M Standard ERS

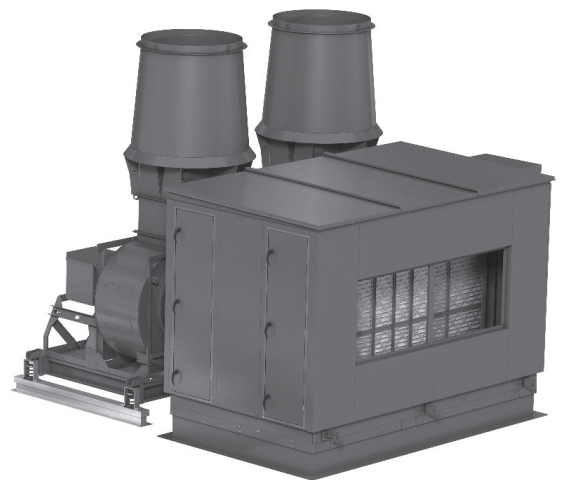

Vektor-C ERS

Greenheck model ERS is a pre-engineered energy recovery system designed to connect directly to a Vektor-M series blower(s) with bypass air plenum or Vektor-C series blower(s). This installation manual covers procedures for receiving, installing and maintaining the energy recovery coil section.

For additional instruction and maintenance information on the Vektor-M series blowers, visit www.greenheck.com and download the Vektor-MH, Vektor-MD and Vektor-MS instruction manual, document number 464652. For additional instruction and maintenance information on the Vektor-C series blowers, visit www.greenheck.com and download the Vektor-CH, Vektor-CD and Vektor-CS instruction manual, document number 471555.

DANGER

Always disconnect, lock and tag power source before installing or servicing. Failure to disconnect power source can result in fire, shock or serious injury.

CAUTION

When servicing the fan, motor may be hot enough to cause pain or injury. Allow motor to cool before servicing.

CAUTION

Precaution should be taken in explosive atmospheres.

DANGER

Pour écarter les risques d'incendie, de choc électrique ou de blessure grave, veiller à toujours débrancher, verrouiller et étiqueter la source de courant avant l'installation ou l'entretien.

ATTENTION

Lors de toute intervention sur la soufflante, le moteur peut être suffisamment chaud pour provoquer une douleur voire une blessure. Laisser le moteur refroidir avant toute maintenance.

ATTENTION

Faire preuve de précaution dans les atmosphères explosives.

General Safety Information

Only qualified personnel should install this fan system. Personnel should have a clear understanding of these instructions and should be aware of general safety precautions. Improper installation can result in electric shock, possible injury due to coming in contact with moving parts, as well as other potential hazards. Other considerations may be required if high winds or seismic activity are present. If more information is needed, contact a licensed professional engineer before moving forward.

1. Follow all local electrical and safety codes, as well as the National Electrical Code (NEC), the National Fire Protection Agency (NFPA), where applicable. Follow the Canadian Electric Code (CEC) in Canada.
2. The rotation of the wheel is critical. It must be free to rotate without striking or rubbing any stationary objects.
3. Motor must be securely and adequately grounded.
4. Do not spin fan wheel faster than maximum cataloged fan rpm. Adjustments to fan speed significantly affects motor load. If the fan RPM is changed, the motor current should be checked to make sure it is not exceeding the motor nameplate amps.
5. Do not allow the power cable to kink or come in contact with oil, grease, hot surfaces or chemicals. Replace cord immediately if damaged.
6. Verify that the power source is compatible with the equipment.
7. Never open access doors to a duct while the fan is running.

Receiving

The transportation carrier has the responsibility of delivering all items in their original condition as received from Greenheck. The warranty period begins at the time of shipment. Upon receiving the product, check to make sure all items are accounted for by referencing the bill of lading to ensure all items were received. The individual receiving the equipment is responsible for inspecting the unit for obvious or hidden damage and recording any damage on the bill of lading before acceptance of the equipment. All claims (if necessary) shall be filed with the final carrier.

Unpacking

Verify that all required parts and the correct quantity of each item have been received, including accessory kit containing flex connector, gasketing, etc. If any items are missing, report shortages to your local representative to arrange for obtaining missing parts. Sometimes it is not possible that all items for the unit be shipped together due to availability of transportation and truck space. Confirmation of shipment(s) must be limited to only items on the bill of lading.

Handling

The ERS is to be rigged and moved by the lifting brackets provided. Location of brackets varies by model and size. Handle each piece in such a manner as to keep from scratching or chipping the coating. Damaged finish may reduce ability of fan or plenum cabinet to resist corrosion. See coating repair section of this manual for details involving touch-up of damaged surfaces.

Storage

If the unit cannot be installed and operated immediately, precautions need to be taken to prevent deterioration of the unit during storage. The user assumes responsibility of the ERS and accessories while in storage. The manufacturer will not be responsible for damage during storage.

Inspection and Maintenance during Storage

While in storage, inspect ERS once per month. Keep a record of inspection and maintenance performed. **Failure to inspect and maintain during storage may void the warranty.**

If moisture or dirt accumulations are found on parts, the source should be located and eliminated. If paint deterioration begins, consideration should be given to touch-up or repainting. ERS with special coatings may require special techniques for touch-up or repair.

When an ERS plenum cabinet is not going to be in service for an extended period of time, cover unit with tarp to protect from dirt and moisture.

NOTE

Do not use a black tarp as this will promote condensation.

Removing from Storage

As the ERS is removed from storage to be installed in its final location, it should be protected and maintained in a similar fashion, until the equipment goes into operation.

Prior to assembly and installation of the Vektor fan and system components, inspect the fan assembly to make sure it is in working order.



General Information

To ensure a successful installation, the instructions in this manual should be read and adhered to. **Failure to comply with proper installation procedures may void the warranty.**

Unit and System Identification Tags

Each fan has a permanently affixed manufacturer's engraved aluminum nameplate containing the model number and individual serial number.

The tag shown is an example of an identification label on the fan. The information provides general details about the fan, as well as containing specific information unique to the unit. When contacting your Greenheck representative with future needs or questions, please have the information on this label available. Tags are mounted in an area which is clearly visible, usually on the side of the fan housing.

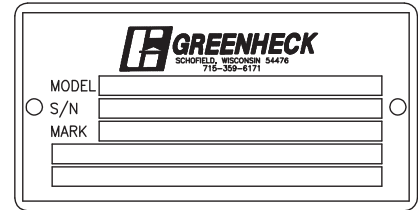

ERS and Vektor fan systems may arrive in component pieces due to shipping restrictions. Individual components of a system have matching identification tags which should be used to identify and assemble the complete system. Assembling systems with different identification tags can cause reductions in the fan(s) performance.

Pre-Installation Checks

Prior to fully assembling and installing the ERS plenum cabinet and Vektor fan bypass plenum components, inspect plenums, coils, and fan assembly to make sure they are in working order.

System Components

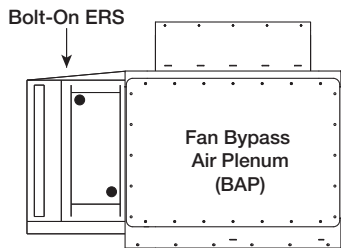

Vektor-M Compact
ERS Sizes 5, 8, 15

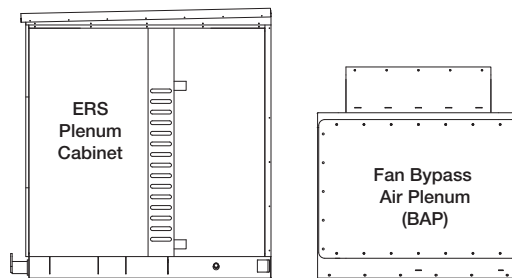

Vektor-M Standard ERS
Sizes 20, 30, 40, 60

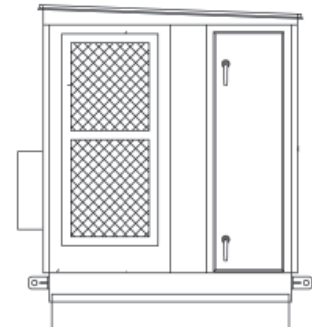

Vektor-C ERS
Sizes 25, 35, 40, 55, 65

Rigging and Lifting

ERS plenum cabinet and fan bypass air plenum (BAP) are to be rigged and moved by the lifting brackets provided.

Vektor-M Compact ERS plenum sizes 5, 8 and 15 ship with the coil section attached to the fan BAP. When lifting these ERS sizes, use the lifting points in the BAP.

Vektor-M Standard ERS plenum sizes 20, 30, 40 and 60 ship with the fan BAP and ERS section separately. Each section should be lifted as supplied. Reference Top View of Bypass Air Plenum and Top View of Plenum Section below for lifting points.

The Vektor-C ERS plenum will ship separate from the fan(s) and will include lifting brackets similar to the Vektor-M Standard ERS plenum cabinet.

The number of lift points varies with size of plenum.

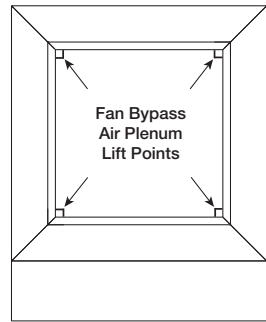

Top View of Bypass Air Plenum and ERS Sizes 5, 8 & 15

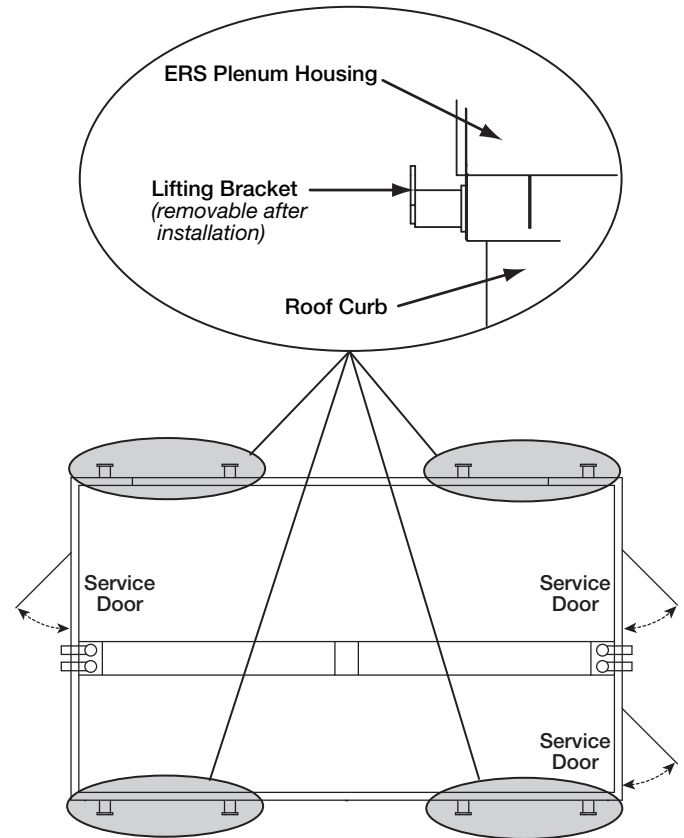

Top View of ERS Plenum Section

CAUTION

When installing an ERS plenum cabinet, ensure the proper protective devices are used to protect personnel from moving parts and other hazards.

Check local codes to ensure compliance for all protective devices.

ERS plenum cabinet with coil section should be lifted/hoisted by lifting brackets provided. These brackets are located around the lower perimeter of the plenum cabinet.

1. Before lifting, be sure that all shipping material has been removed from unit.
2. To assist in determining rigging requirements, weights are shown below.
3. Unit must be lifted by the lifting brackets provided on base structure.
4. Rigger to use suitable mating hardware to attach to unit lifting brackets.
5. Two spreader bars must span the unit to prevent damage to the plenum cabinet by the lift cables.
6. Always test-lift the unit to check for proper balance and rigging before hoisting to desired location.
7. Never lift units in windy conditions.
8. Preparation of curb and roof openings should be completed prior to lifting unit to the roof. Verify the curb has the gasket seal on the top surface.
9. Do not use fork lift to handle unit.

Unit Weights (ERS Plenum Section Only)

Cabinet Size	Cabinet Height	Weight (lbs)*
20	075	3600
	090	4400
25	98	4400
30	075	4100
	090	4700
35	98	5650
40 (C)	98	6300
40 (M)	075	5200
	090	5900
55	98	8159
60	075	6600
	090	7600
	110	8000
65	98	9226

* ERS weights shown are for largest coil and filter options per cabinet size. Based on dry weight. Weights for custom designed units may vary.

Plenum Service and Access Locations

• Sizes 20, 25, 30, 35, 40, 60

Standard M series and C series ERS plenum cabinets require minimum clearances for access on three sides for routine maintenance. Filter replacement, drain pan inspection and cleaning, coil inspection, damper actuator adjustments and inspection are examples of routine maintenance that must be performed. Coil and filter sections are always provided with a service door or panel for proper component access. Clearances for component removal may be greater than the service clearances. Refer to page 15 for coil clearances.

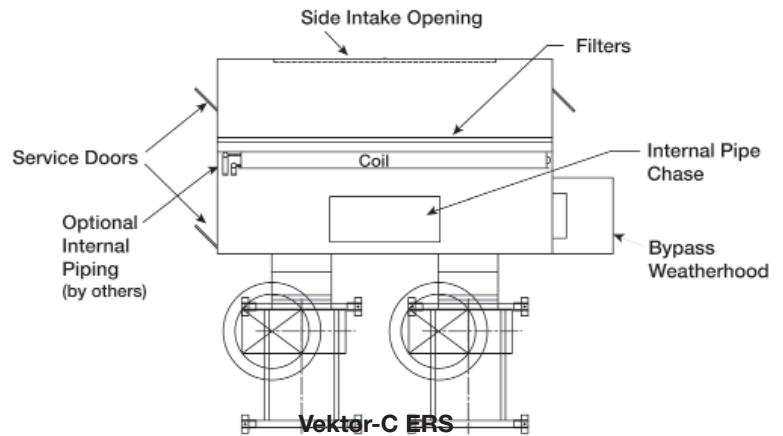
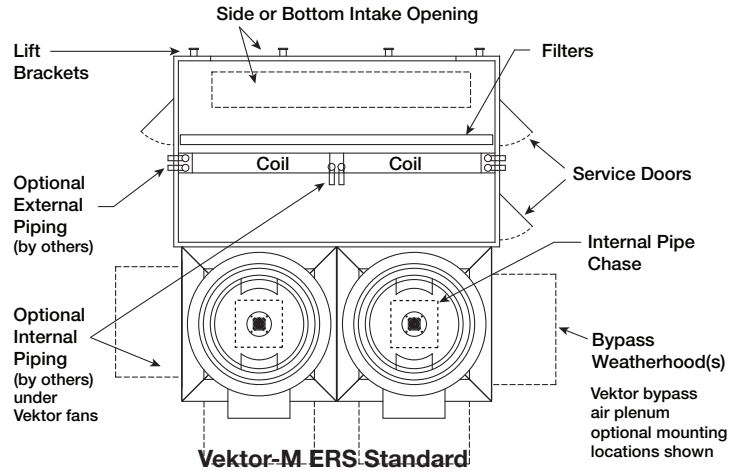

Assembly and Installation (Vektor-M Compact)

Rooftop units require curbs to be mounted first. The duct connections must be located so they will be clear of structural members of the building.

1. Assemble factory supplied roof curbs

Roof curbs are Model VKCURB, which are shipped knocked down and require field assembly (by others). See Greenheck document number 475588 (VKCURB Curb Assembly Instructions) for ERS sizes 5, 8 and 15.

Sealing

After all sections have been assembled, caulk (supplied) all seam joints to provide final sealing of roof curb sections. Follow caulk manufacturers recommendations for proper application.

2. Lift and install roof curb

Roof curb can be assembled at installation location on the roof deck or at ground level and lifted into position. To lift from ground to roof deck, use spreader bar and support both end and center sections. Locate curb over roof opening. Check that the diagonal dimensions are within $\pm 1/8$ inch of each other and adjust as necessary. Check curb or structural supports for levelness. Both must be level to ensure proper drainage from plenum and fan(s). Shim as required to level. Attach curb to roof deck or support structure as specified by structural engineer. Attach supplied gasketing to top of curb.

NOTE
Gasketing material (shipped with Vektor fan) should be placed on the top edge of secured roof curb prior to placing the bypass air plenum (BAP) on the curb.

3. Bypass air plenum installation

The bypass air plenum and energy recovery system (ERS) sections are delivered fully assembled. After BAP has been lifted into position, plenum should be secured to roof curb. Refer to the submittal drawing for the orientation of any bypass air plenum (BAP) dampers or air inlet locations. Bottom of the BAP has a removable skirt section with pre-punched holes. These holes will align with holes and nutserts in the roof curb if the roof curb was provided by same manufacturer. If the roof curb is from another supplier, use the holes in the skirt as a template. Allow gasketing to compress before securing. When securing BAP to curb, install using moly-coated 316 stainless steel screws (provided) in all holes.

If BAP is not being mounted on a roof curb, it can be secured to either structural steel or concrete pad. Full perimeter under BAP is required. Method used to secure the BAP to either structural support(s) or concrete pad is determined by site or structural engineer. If BAP is welded to support structure, repair the area where coating was burnt off. See coatings repair section of this manual for details involving touch-up of damaged surfaces.

Mounting the BAP to roof curbs from manufacturers other than Greenheck or not following proper mounting instructions may impact fan performance and void warranty.

4. Fan rigging, lifting and installation

For installing the remainder of the fan system, refer to Greenheck document 464652 (Model Vektor-MH, Vektor-MD and Vektor-MS Laboratory Exhaust System IOM).

Assembly and Installation (Vektor-M Standard)

Rooftop units require curbs to be mounted first. The duct connections must be located so they will be clear of structural members of the building.

1. Assemble factory supplied roof curbs

Roof curbs are Model VKCURB, which are shipped knocked down and require field assembly (by others). Refer to Vektor ERS Fan Plenum Curb Assembly Instructions, document number 474117, for additional details for ERS sizes 20, 30, 40 and 60.

NOTE
Gasketing material (shipped with Vektor fan) should be placed on the top edge of secured roof curb prior to placing the Vektor bypass air plenum (BAP) and ERS plenum cabinet on the curb.

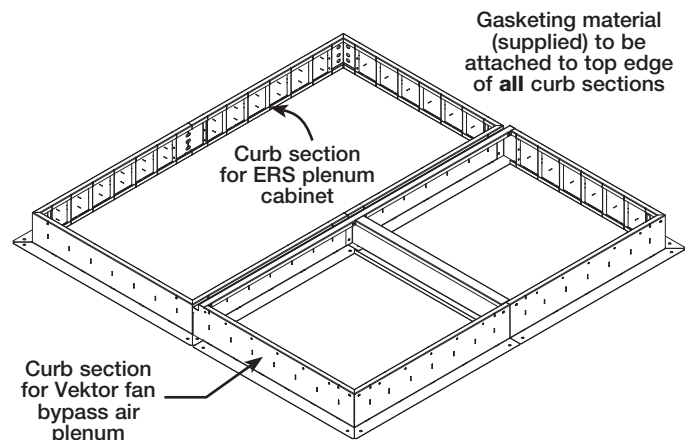

Determine the placement of the plenum sections relative to each other. Please refer to the submittal drawing for the orientation of any BAP dampers or air inlet locations.

Assembly and Installation (Vektor-M Standard) (continued)

2. Cut roof opening for bottom intake

Layout the unit roof openings such that exhaust inlet of the unit will line up with the corresponding ductwork; refer to Plenum Bottom Inlet Openings on page 10. Do not make opening larger than necessary. Be sure to allow for the recommended service clearances.

3. Lift and install roof curb

Roof curb can be assembled at installation location on the roof deck or at ground level and lifted into position. To lift from ground to roof deck, use spreader bar and support both end and center sections. Locate curb over roof opening. Check that the diagonal dimensions are within $\pm 1/8$ inch of each other and adjust as necessary. Check curb or structural supports for levelness. Both must be level to ensure proper drainage from plenum and fan(s). Shim as required to level. Attach curb to roof deck or support structure as specified by structural engineer. Attach supplied gasketing to top of curb.

4. Set the ERS plenum cabinet

Lift ERS plenum cabinet to a point directly above the curb and duct openings. While lowering, guide cabinet to align with duct opening. Roof curbs fit inside the unit base. Set ERS plenum cabinet into place on assembled VKCURB. Allow gasketing on curb to compress before setting the fan bypass air plenum. Make sure the unit is properly seated on the curb and is level.

5. Set the Vektor fan bypass air plenum

Before moving the Vektor fan BAP into position, gasketing must be installed to seal the plenum sections against leakage.

This gasketing is attached to the ERS plenum cabinet prior to shipment. Verify that it is in place and not damaged or missing prior to joining the two plenums together.

The assembly hardware (stainless steel bolts) required to join the sections is located in the Vektor fan bypass air plenum accessory kit.

Assembly Hardware Kit

5/16 - 18 UNC x 2-1/2 lag bolts
5/16 inch flat washers
1/2 inch flat washers
3/4 inch flat washers

Quantities in hardware kit will vary by unit size and configuration.

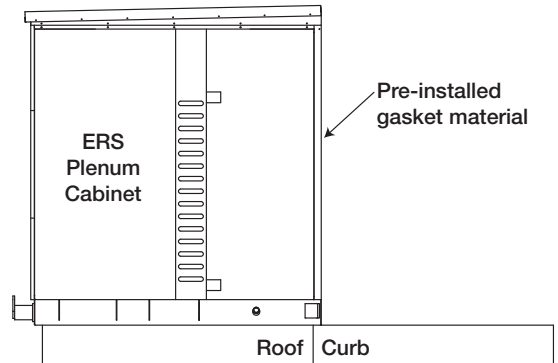

Vektor-M Standard ERS Plenum Cabinet Installed on Roof Curb

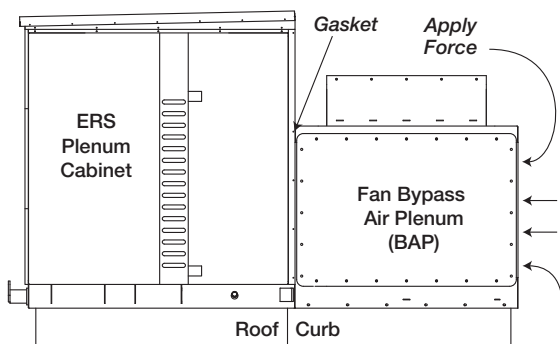
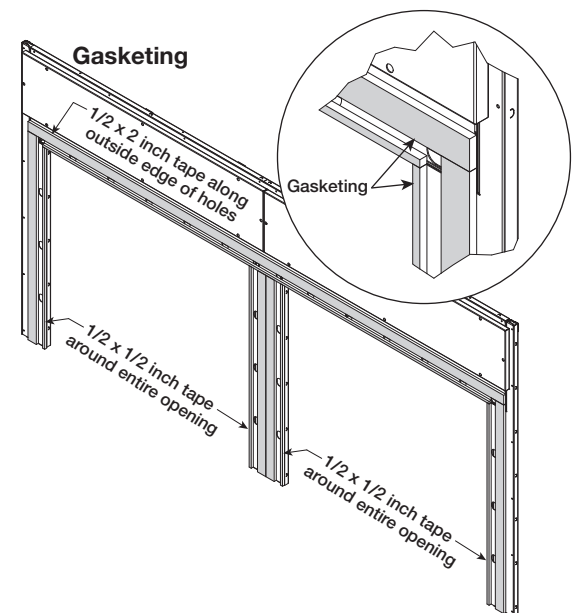

ERS and Vektor Fan Bypass Plenum Assembly Installed on Roof Curb

Lift and set the Vektor fan BAP on the curb against the ERS plenum. Follow rigging and lifting instructions in the Vektor-MH, Vektor-MD, and Vektor-MS installation instruction, document number 464652. While lowering BAP into final position and just before the base touches the curb, apply force on front of plenum. This will tighten the gap between

the marriage wall of ERS and BAP. Gasket between ERS and BAP must be evenly compressed to form airtight seal with no gaps. Inspect the entire joint between sections. If gap exists, then carefully hoist the BAP slightly and apply force until contact is made with ERS section as shown in figure below, making sure to line up bolt holes. If required, use come-along or other pulling hardware to draw sections tightly together. Once this gap is removed, slowly lower BAP into final position.

Assembly and Installation (Vektor-M Standard) (continued)

Inside the ERS plenum are slots along the marrying sections which accept the bolt and washer assemblies. Using the hardware kit, attach the unit sections by bolting together frame extrusion from the inside.

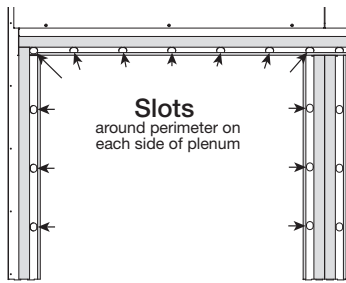

Slot Detail

Tighten the bolt-washer assemblies to the top and both sides of the joining sections. Start on the lower sides and work towards the top. As the bolts are tightened, the plenum sections will draw together. Use anti-seize gel to prevent galling/welding of all stainless steel fasteners. If necessary, pull the units together with a mechanical come-along device at the structural base of the unit or at lifting lugs.

External brackets, one for each side, transition and connect lower section of the bypass air plenum to the ERS plenum cabinet. These brackets ship with the BAP and also complete the connection between the BAP and roof curb.

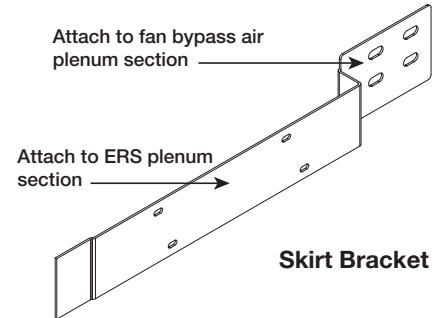

Skirt Bracket

6. Fan rigging, lifting and installation

After the ERS and Vektor fan BAP are joined and secured, the Vektor-M fans can be set on the BAP. Refer to the Vektor-MH, Vektor-MD and Vektor-MS installation instruction, document number 464652 for this procedure.

Assembly and Installation (Vektor-C)

1. Assemble factory supplied roof curbs

Roof curbs are modular in construction and require field assembly.

Each roof curb will arrive in sections along with an assembly kit for field installation. Verify all roof curb sections and assembly kit(s) have arrived for each fan mark and are in good condition prior to signing the shipping receipt.

Use one Roof Curb Assembly Kit with gasketing and hardware for each section to be joined. Attach self-adhering foam gasketing (supplied) to one side of either joining section (see Drawing 1a). Gasketing should be placed to form a continuous seal. Corner locations may need second strip to cover seam joints. Supplied hardware should then be used to secure the two sections together as shown (see Drawing 1b). Hold nut with wrench while bolt is tightened.

Drawing 1a

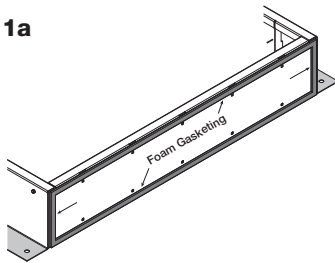

Drawing 1b

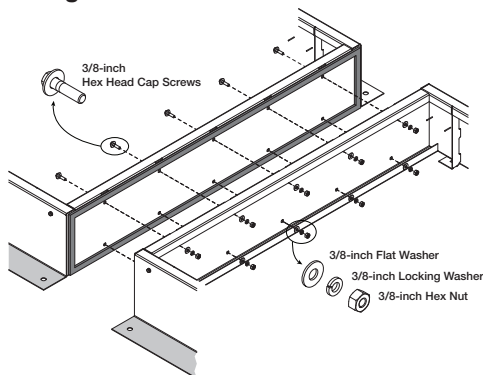

Roof Curb Sections			
ERS Size	End Section(s)	Center Section(s)	Quantity of Roof Curb Assembly Kit(s)
25	2	0	1
35	2	0	1
40	2	0	1
55	2	1	2
65	2	1	2

Assembly and Installation (Vektor-C) (continued)

Drawing 1c

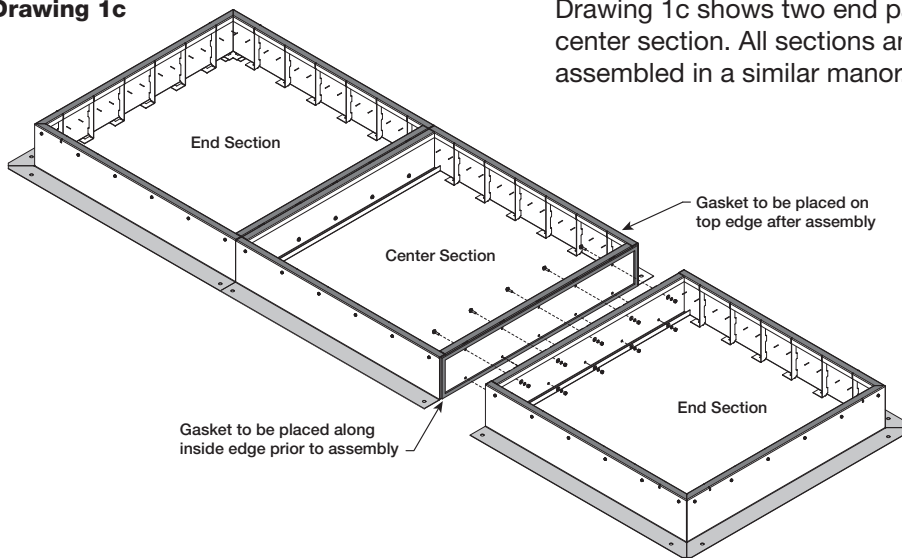

Drawing 1c shows two end panels and single center section. All sections and configurations are assembled in a similar manor.

Sealing

After all sections have been assembled, caulk (supplied) all seam joints to provide final sealing of roof curb sections. Drawing 2 shows seams to be caulked. Follow caulk manufacturers recommendations for proper application.

2. Cut roof opening for bottom intake on Vektor-M series locate curb and pipe chase for Vektor-C series coil

Layout the unit roof openings such that exhaust inlet of the unit will line up with the corresponding ductwork; refer to Plenum Bottom Inlet Openings on page 10. Do not make opening larger than necessary. Be sure to allow for the recommended service clearances.

3. Lift and install roof curb

Roof curb can be assembled at installation location on the roof deck or at ground level and lifted into position. To lift from ground to roof deck, use spreader bar and support both end and center sections. Locate curb over roof opening. Check that the diagonal dimensions are within $\pm 1/8$ inch of each other and adjust as necessary.

Check curb or structural supports for levelness. Both must be level to ensure proper drainage from plenum and fan(s). Shim as required to level. Attach curb to roof deck or support structure as specified by structural engineer. Attach supplied gasketing to top of curb.

4. Set the ERS plenum cabinet

Lift ERS plenum to a point directly above the curb. While lowering, guide the plenum cabinet to align with curb. Roof curb will fit inside the unit base with skirt. Set ERS plenum cabinet into place on assembled VKCURB. Make sure the unit is properly seated on the curb and is level. Attach plenum to roof curb using supplied hardware kit.

5. Installing transition to Vektor-C fan

Before setting the Vektor-C fan(s) into position, install the square to round transition to the isolation damper on the ERS plenum cabinet. Close up the actuator cover after wiring the damper.

After transition piece(s) are installed, the Vektor-C fans can be set on the base, rails, or equipment supports, etc. Refer to the Vektor-CH, Vektor-CD and Vektor-CS installation instruction, document number 471555 for this procedure.

Attach the round transition to the fan inlet using provided flex connect.

Installation

Installations with inlet configurations that deviate from this standard may result in reduced fan performance. Restricted or unstable flow at the fan inlet can cause pre-rotation of incoming air or uneven loading of the fan wheel yielding large system losses and increased sound levels.

Drawing 2

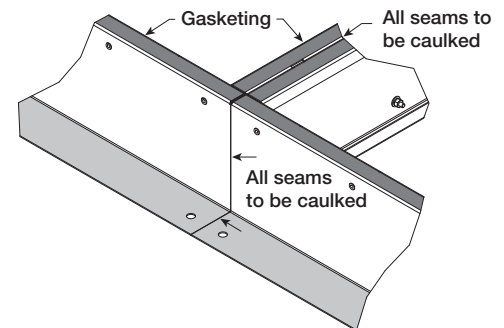

NOTE

Gasketing material (shipped with Vektor fan) should be placed on the top edge of secured roof curb prior to placing the ERS plenum cabinet on the curb.

Duct Connections

Plenum Bottom Inlet Opening

• Vektor-M series

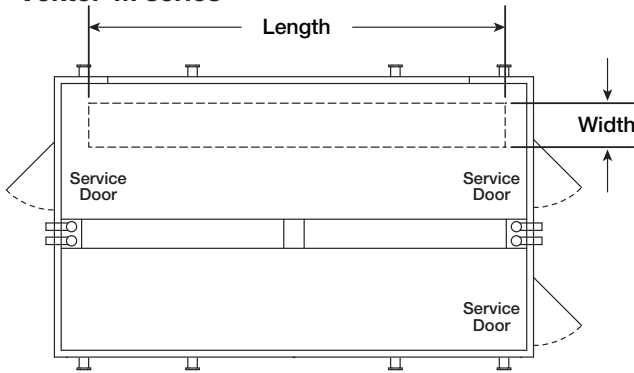

Cabinet Size	Length (inches)	Width (inches)
20	86	25
30	120	25
40	172	25
60	236	25

Plenum Side Inlet Duct Dimensions

• Vektor-M series

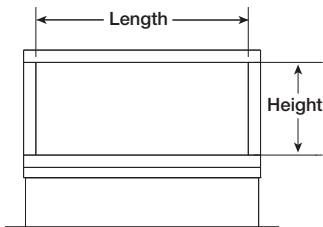

Cabinet Size	Length (inches)	Height (inches)
5	40	43
8	60	43
15	127	43

• Vektor-C and Vektor-M

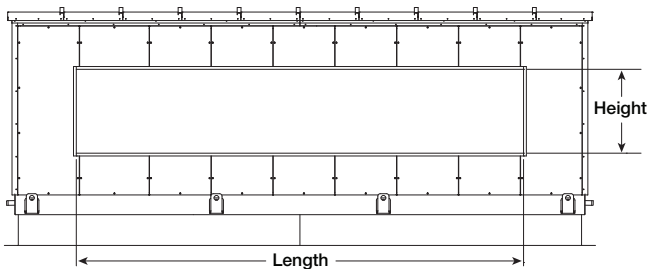

Cabinet Size	Length (inches)	Height (inches)
20	86	30
25	96	36
30	120	30
35	144	36
40 (C)	168	36
40 (M)	172	30
55	240	36
60	236	30
65	288	36

Installation of all ducts should be done in accordance with SMACNA and AMCA guidelines.

Connect primary exhaust air ducts to unit using flanged connections. Screw ducts directly to unit using stainless steel self-tapping sheet metal screws. Contractor is responsible for providing transitions to accommodate difference in sizing between unit and building ducts. Duct connections to collar-type openings can be made with S-cleats or overlapping joints. Apply caulking around the duct connection. Failure to ensure a tight fit and properly seal duct connections can cause air leakage and system performance problems from the contaminated airstream.

Bottom Inlet

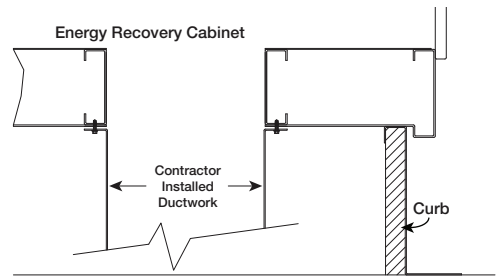

Flanged

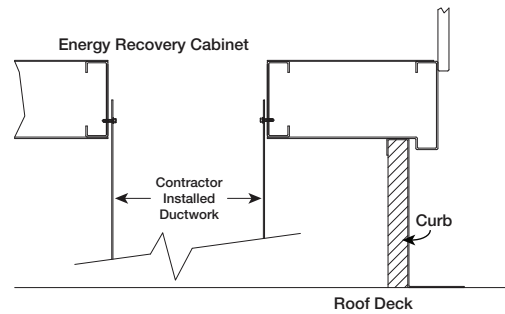

Flush

Side Inlet

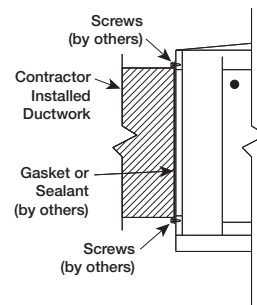

**Exterior connection
All Sizes**

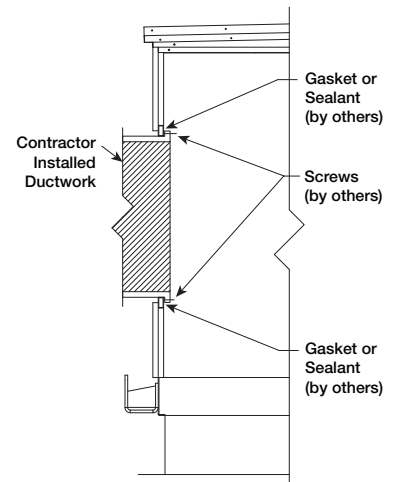

**Interior flanged ductwork connection
ERS 20-65**

Drain Trap

Coils are provided with a stainless steel drain pan with 2-inch (Vektor-M standard series) or 3/4-inch (Vektor-C series) male NPT drain connection. A drain trap must be connected to the drain connection to allow excess water to flow out of the drain pan. More importantly though, due to the negative internal static pressure of the coil compartment, installing the drain trap prevents outdoor air from being pulled into the drain pan and consequently forcing water out of the pan and into the unit.

To ensure the drain trap works properly, the trap height must account for the difference in static pressure between ambient conditions outside the unit and the internal negative pressure of the coil compartment.

Refer to local codes to determine drainage requirements. If draining onto roof, place a drip pan below drain to protect roof. If draining onto roof is not acceptable, a drain line must be attached to the trap. The drain line must be pitched away from the unit at least 1/8-in. per foot. On longer runs, an air break should be used to ensure proper drainage. Local codes may require drainage into a waste water system.

Drainage problems not only occur from improper drain trap design, but also from lack of maintenance of the cooling coil compartment. Algae can form in the drain pan and trap and cause reduced water flow, which can result in a backup into the system. Regular maintenance will prevent this from occurring. If the drains have a clean-out opening, be sure to close the opening after cleaning.

NOTE

A conservative method of trap design is to add 1 inch minimum to total static pressure.

- Connect this end to the plenum drain

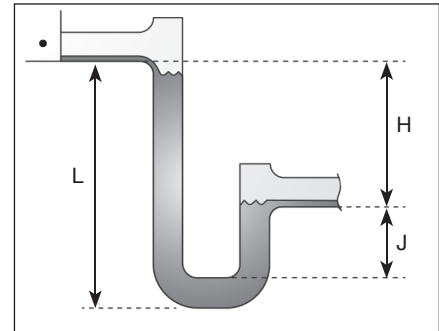

$H = 1 \text{ in. for each inch of maximum negative static pressure plus } 1 \text{ in.}$

$J = 1/2 \text{ of } H$

$L = H + J + \text{Pipe diameter}$

Field Coating Touch-Up for Scratched Areas

Standard coating and color for the Vektor laboratory exhaust system is Greenheck's LabCoat™, RAL7023 Concrete Grey.

Failure to perform touch-ups may result in rust or corrosion and accelerate the fade in color and is not covered under warranty.

TOUCH-UP PAINT REPAIR KIT CONTENTS

- One Zinc Clad aerosol can
- One pint (recoat epoxy primer grey) with one pint (recoat epoxy primer catalyst)
- One quart H.S. Polyurethane
- One Scotch-Brite™ scratch pad
- Two 1-1/2 inch wide paint brushes
- Four pint-sized empty cans for mixing
- One quart-sized empty can for mixing
- Zinc repair instructions
- MSDS sheets

NOTE

While Greenheck provides heavy-duty, quality products for marine environments, routine paint touch-ups may be required in coastal regions where salt or marine air could damage the coating on a Vektor. The severe environment will accelerate the damage from any scratches or chips and it is recommended that those be repaired immediately.

To order coating repair kits, please reference part number HAZ2597 PAINT FIELD REPAIR KIT, RAL7023 CONCRETE GREY. Please contact factory with your fan's serial number for colors other than our standard RAL7023 Concrete Grey.

Coils (All Sizes)

Installation of Water Coil Piping

Guidelines for the installation of the coil have been provided to ensure proper performance of the coils and their longevity. These are general guidelines that may have to be tailored to meet the specific requirements of any one job. As always, a qualified party or individual should perform the installation and maintenance of the coil. Protective equipment such as safety glasses, steel toe boots and gloves are recommended during the installation and maintenance of the coil.

All field piping must be self-supporting. System piping should be flexible enough to allow for the thermal expansion and contraction of the coil.

Water Coil Installation Recommendations

1. Piping should be in accordance with accepted industry standards. Always use a back up wrench on the coil connections when attaching the piping to the coil if pipe thread connections are utilized.
2. Pipe sizes for the system must be selected on the basis of the head [pressure] available from the circulating pump.
3. Internal coil plumbing: Standard Vektor-M series under each fan there is a raised, insulated cover panel to be used when internal pipe connections are desired. For the Vektor-C series 20-60, there is an insulated panel set into the floor. Either remove this panel to run plumbing or punch appropriately sized holes in the panel to allow piping to pass without rubbing and space for piping insulation, sealant and grommets (by others).
4. For C series, external piping connections, holes will need to be field drilled in the side of the ERS plenum. Drill appropriately sized holes in the panel to allow piping to pass without rubbing and space for piping insulation, sealant and grommets (by others).
5. Connect the water supply to the bottom connection on the air leaving side and the water return to the top connection on the air entering side.
6. The air vent at the uppermost point should be temporarily opened during system start-up to release all of the air from the coil. To maintain heat transfer capacity, periodically vent any air in the coil.
7. Water coils are not normally recommended for use with entering air temperatures below 40°F. Glycol solutions or brines are the only freeze-safe media for operation of water coils for low entering air conditions.
8. Two-position control valves, modulating valves, three-way valves or a combination of these controls can accomplish control of water coils. Follow the recommendations of the control manufacturer regarding types, sizing and locations.

Coil Piping Identification

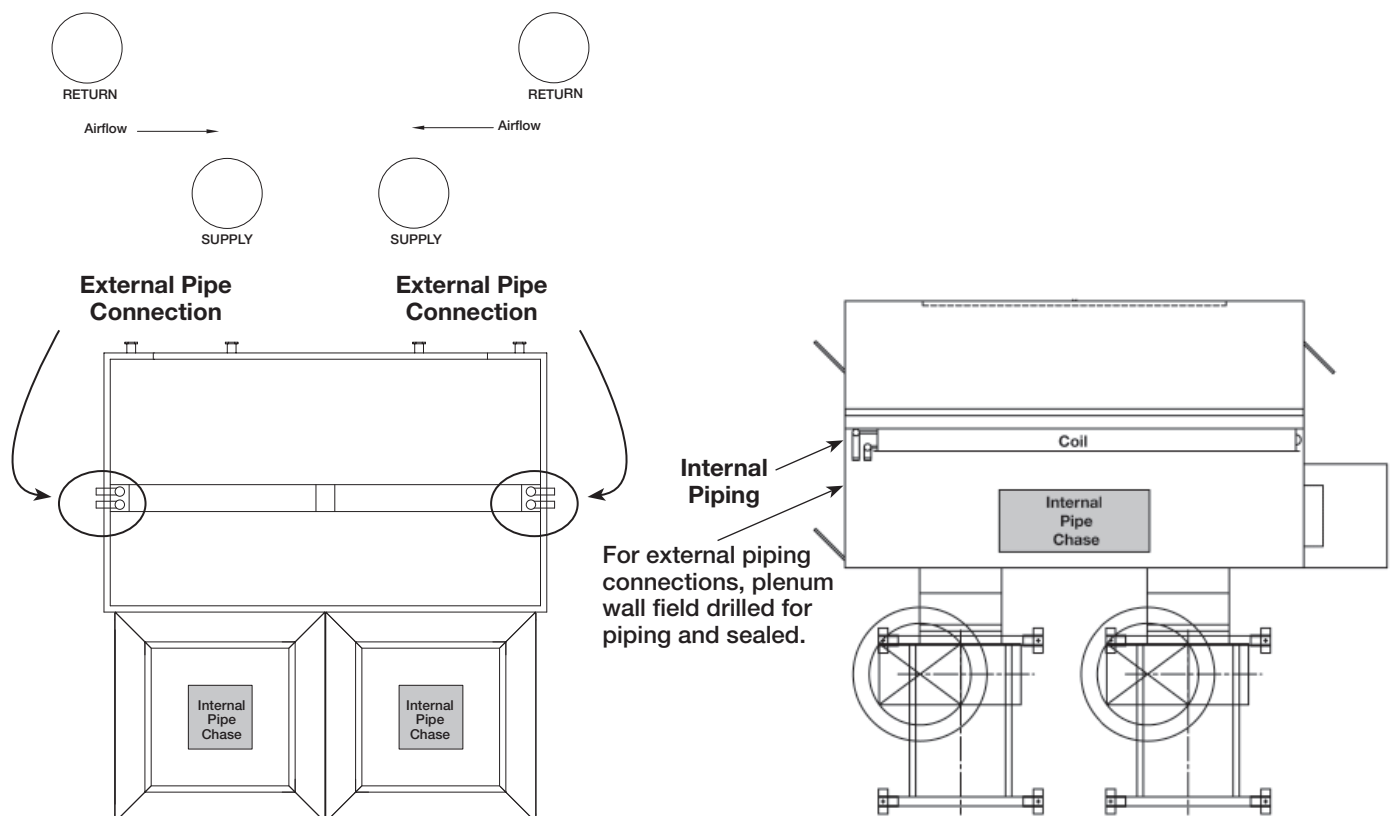

NOTE

Vent and drain connections are provided on Greenheck water coils unless otherwise specified. This allows the coils to be drained. Keep in mind that when draining the coils, all water may not drain from the coil. In order to completely drain the coil to prevent the possibility of freezing during cold ambient temperatures, air or nitrogen pressure must be utilized to blow any remaining water from the coil.

Coil Installation Checklist

Use the following checklist to verify that all necessary installation procedures have been completed.

1. Coils are installed with airflow in same direction as indicated on the coil nameplate or casing.
2. Condensate drain pans and piping are installed with a trap in the condensate line and piping is insulated and heated if installed in applications that are below freezing.
3. Clean filters are installed upstream.

Optional Accessories (Vektor-M series - Sizes 20, 30, 40, 60)

Dirty Filter Sensor (Magnehelic Gauge)

Dirty filter sensor monitors pressure drop across the exhaust air filters. Visual gauge on the side of the plenum cabinet indicates the pressure across the filter section. Periodic inspection is necessary to determine whether filters need to be replaced.

Vapor Tight Lights

Vapor tight lights provide light to each of the compartments in the energy recovery plenum. The lights are wired to a junction box mounted on the outside of the unit. The switch requires a separate power source to allow for power to the lights when the unit main disconnect is off for servicing.

Electrical Package

The electrical package consists of a switch and GFCI receptor mounted in a two gang, "in use" NEMA-3R rated box with cover plate. This box would be mounted at the factory near the ERS plenum access doors.

The GFCI is rated for 15A, 125 VAC and is provided with SafeLock™ Protection. This feature denies power if the GFCI is incorrectly wired or if the GFCI is damaged and protection is lost. The GFCI is also equipped with a trip indicator light to easily identify a tripped condition. Receptor uses a NEMA 5-15 R configuration.

Supplied switch is industrial extra heavy duty grade with back and side wiring. The switch has a rating of 20A, 120/277VAC and single pole. The switch comes from the factory pre-wired to lights within the ERS plenum section.

Electrical wiring for power to the electrical panel is to be installed by a licensed electrician in compliance with all local and national codes.

Routine Maintenance

Once the unit has been put into operation, a routine maintenance program should be set up to preserve reliability and performance. Items to be included in this program are:

- **Coil Maintenance**
Check for cleanliness (coil and drain pan).
- **Winterizing Coils**
Drain. Fill with antifreeze. Drain.
- **Internal Filter**
Check for cleanliness. Replace if required.
- **Door Seal**
Check if intact and pliable.

CAUTION

Use caution when removing access panels or other unit components, especially while standing on a ladder or other potentially unsteady base. Access panels and unit components can be heavy and serious injury may occur.

Coil Maintenance:

Cleaning

Coils should be kept clean to maintain maximum performance. For operation at its highest efficiency, the coil should be cleaned often during periods of high cooling demand or when dirty conditions prevail. Power should be disconnected and locked out and motors should be covered to ensure that no moisture penetrates into the windings causing motor failure if applicable. Remove large debris from the coils and straighten fins before cleaning. Clean coils with cold water and detergent or with one of the commercially available chemical coil cleaners. Rinse coils thoroughly after cleaning. For coils with fragile fins or high fin density, foaming chemical sprays and washes are available. Many coil cleaners contain harsh chemicals, so they must be used with caution by qualified personnel only. Care must be taken not to damage the coils. **FINS ARE SHARP!** Use caution when working with coils.

CAUTION

Do not use acidic chemical coil cleaners. Do not use alkaline chemical coil cleaners that, after mixing, have a pH value greater than 8.5 without also using an aluminum corrosion inhibitor in the cleaning solution. Failure to follow these guidelines or the manufacturer's instructions for use of cleaning chemicals could result in damage to the unit.

Fin Straightening

Coil fins may have been bent during shipping or servicing, and should be straightened to maintain maximum heat transfer. Reduction of the effective coil surface will correspondingly reduce coil capacity. Always check fin appearance after any handling of the coil and after any servicing is done near the coils. Fin combs are sized according to number of fins per inch of the coil. For relatively small bends that require only minor repair, other tools may be used to evenly space the fins. Be careful not to damage the coils.

Winterizing Coils

During any extended down time, all water should be drained from the coil. The coil should then be thoroughly flushed with a glycol solution to prevent freeze damage.

Drain Pan

Drain pans may contain moisture; therefore, algae and other organisms will grow due to airborne spores and bacteria. Scheduled cleaning is necessary to prevent build-up from clogging the drain. Drain pans should also be kept clean to prevent growth of bacteria and the spread of disease.

WARNING

Biological Hazard! All drain pans and coils should be cleaned on a regular schedule by qualified personnel to prevent the growth of bacteria.

Filters

Filters upstream of the coil should be checked regularly for dirtiness and clogging. If the filters are dirty, they should be replaced. It is important that the coils stay clean to maintain maximum heat transfer capability.

Routine Maintenance (continued)

Filter Replacement (All Sizes)

Filters are located only in the coil plenum section. Access is needed from both sides of the plenum to change all the filters. Unit may have either 2-inch MERV 8 filters or 4-inch MERV 13 filters for the Vektor-M series ERS or 2-inch MERV 13 filters for the Vektor-C series ERS depending on the application requirements. Use equivalent MERV rating filters when replacing.

Change the filters regularly. Pressure drop readings can be used to determine when a filter should be replaced. Prefilters should be replaced at filter manufacturers recommended pressure drop change out or as required by system design.

All filter sections have access provided by a door. Filters used in Greenheck ERS plenums can be changed in most cases by sliding them out and replacing. In some cases, filters are secured to frames using a clip.

Cabinet Size	Quantity of Filters	Filter Size (in.)
5	4	20x20
8	6	20x20
15	10	20x25
20	12	24x18
25	15	24x24
30	18	24x18
35	18	24x24
40 (C)	24	24x24
40 (M)	24	24x18
55	30	24x24
65	36	24x24
60 (075, 090)	30	24x18
60 (110)	40	24x18

Coil Change Out Procedure

Coils can only be pulled out through the side of the plenum cabinet. Side panels which are nearest to the coil can be removed if the coil needs to be replaced. Size 20 and 25 ERS plenums only have a single coil and do not require coil removal clearances on both sides. If necessary, both coils can be removed through the same side of the plenum housing. This process would require the removal of an additional spacer panel that separates the two coils within the unit.

Cabinet Size	Minimum Clearance (inches)
20	114
25	128
30	74 (each side)
35	88 (each side)
40 (C)	100 (each side)
40 (M)	100 (each side)
55	136 (each side)
65	160 (each side)
60	132 (each side)

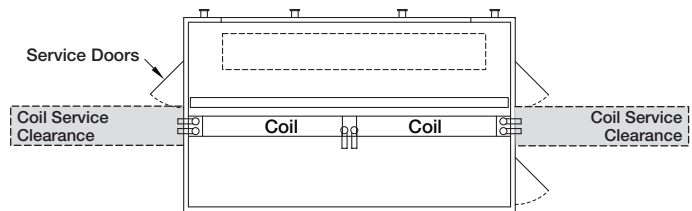

Maintenance Log

Date _____ Time _____ AM/PM

Notes: _____

Date _____ Time _____ AM/PM

Notes: _____

Date _____ Time _____ AM/PM

Notes: _____

Date _____ Time _____ AM/PM

Notes: _____

Date _____ Time _____ AM/PM

Notes: _____

Date _____ Time _____ AM/PM

Notes: _____

Date _____ Time _____ AM/PM

Notes: _____

Date _____ Time _____ AM/PM

Notes: _____

Our Commitment

As a result of our commitment to continuous improvement, Greenheck reserves the right to change specifications without notice.

Product warranties can be found online at Greenheck.com, either on the specific product page or in the literature section of the website at Greenheck.com/Resources/Library/Literature.

Greenheck's Vektor-ERS catalog provides additional information describing the equipment, fan performance, available accessories, and specification data.

AMCA Publication 410-96, Safety Practices for Users and Installers of Industrial and Commercial Fans, provides additional safety information. This publication can be obtained from AMCA International, Inc. at www.amca.org.



Assembly Instructions

READ THROUGH THESE INSTRUCTIONS PRIOR TO STARTING ASSEMBLY.

Document Instructions

Use Document #1016722 with fastener kits 914746, 914747, 914748 and 914749. These kits are to be used with the Vektor-M series. The fasteners contained within the kit are to be used to join the bypass air plenum (BAP) to mating energy recovery plenum (ERS). Use the images located within this document to locate the position of the fasteners on the unit.

Assembly Instructions

- See Greenheck Document #474118 (Installation, Operation and Maintenance Manual: Energy Recovery Laboratory Exhaust) for full installation instructions.
- The fastener kit includes fasteners to attach one BAP to the ERS plenum. If the fan array includes multiple BAP sections, multiple fastener kits will be supplied.
- See image on right to locate bolt holes. Install 316 stainless steel bolts with three washers from inside of the ERS plenum through the marriage wall into the threaded nut-inserts on mating wall of BAP.

Tools Required

- Cordless drill with 1/2 inch nut setter or 1/2 inch wrench

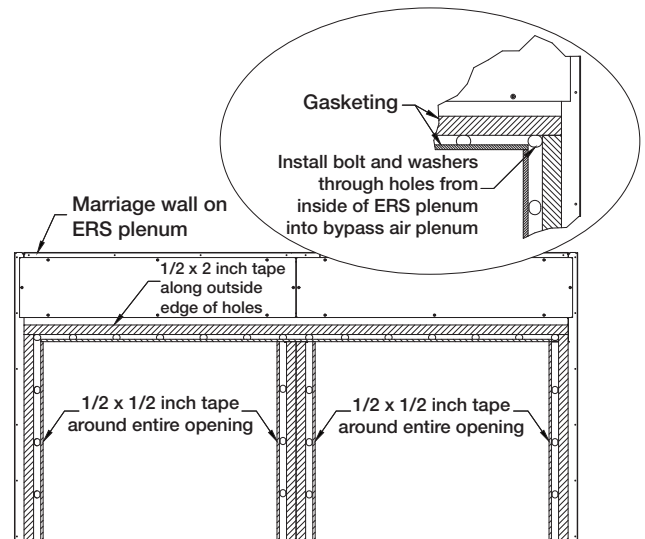
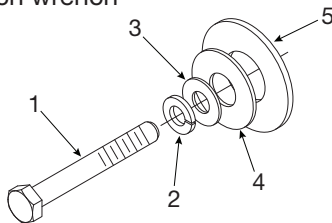

Plenum view from fan side

NOTE

If gasketing on marriage wall is missing, consult factory before installing hardware.

BAP TO ERS PLENUM FASTENER KIT		MD2 914746	MD3/MD4 914747	MD5/MD6 914748	MD7 914749
Part Description	Part #	Quantities			
1 CS,HH,,313-18X2.5,SS,316	416866	11	13	15	21
2 WSHR,LOCK,,313,SS,316	415811	11	13	15	21
3 WSHR,FLAT,,313X.045X.34X.75,SS,316	415798	11	13	15	21
4 WSHR,FLAT,,5X.06X.531X1.25,SS,316	415803	11	13	15	21
5 WSHR,FLAT,,75X.1X.812X1.75,SS,316	415830	11	13	15	21
Assembly Instructions	1016722	1	1	1	1

Maintenance Log

Date _____ Time _____ AM/PM

Notes: _____

Date _____ Time _____ AM/PM

Notes: _____

Date _____ Time _____ AM/PM

Notes: _____

Date _____ Time _____ AM/PM

Notes: _____

Date _____ Time _____ AM/PM

Notes: _____

Date _____ Time _____ AM/PM

Notes: _____

Date _____ Time _____ AM/PM

Notes: _____

Date _____ Time _____ AM/PM

Notes: _____

Our Commitment

As a result of our commitment to continuous improvement, Greenheck reserves the right to change specifications without notice.

Product warranties can be found online at Greenheck.com, either on the specific product page or in the literature section of the website at Greenheck.com/Resources/Library/Literature.

AMCA Publication 410-96, Safety Practices for Users and Installers of Industrial and Commercial Fans, provides additional safety information. This publication can be obtained from AMCA International, Inc. at www.amca.org.

