

## Installation, Operation and Maintenance Manual

Please read and save these instructions for future reference. Read carefully before attempting to assemble, install, operate or maintain the product described. Protect yourself and others by observing all safety information. Failure to comply with these instructions will result in voiding of the product warranty and may result in personal injury and/or property damage.

### Table of Contents

---

474117 – Vektor-ERS Curb Assembly . . . . .	.2
1016916 – Vektor-ERS Fastener Kit Knock Down ERS Roof Curb . . . . .	.5
1016917 – Vektor-ERS Fastener Kit ERS Curb Insulation Clips . . . . .	.7
1016918 – Vektor-ERS Fastener Kit Plenum Assembly to Roof Curb . . . . .	.8
1032090 – Vektor-ERS Fastener Kit Interior Section of Modular Roof Curb . . . . .	.9

## Vektor® ERS-MD Fan Plenum Curb Assembly Instructions

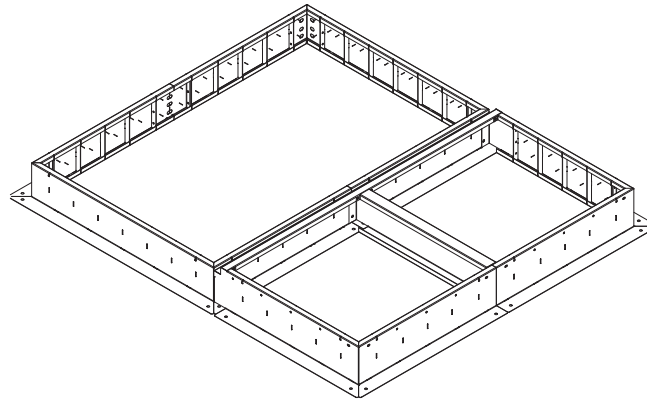

Greenheck VK-ERS curb is shipped in sections for field assembly. All required hardware is provided. Attachment to roof or structural members and building weather protection by others.

### Curb Section Parts List

#### ERS Plenum Section

Description	Quantity
End Panel	2
Corner Bracket	4
Side Panel	4
Side Bracket	2

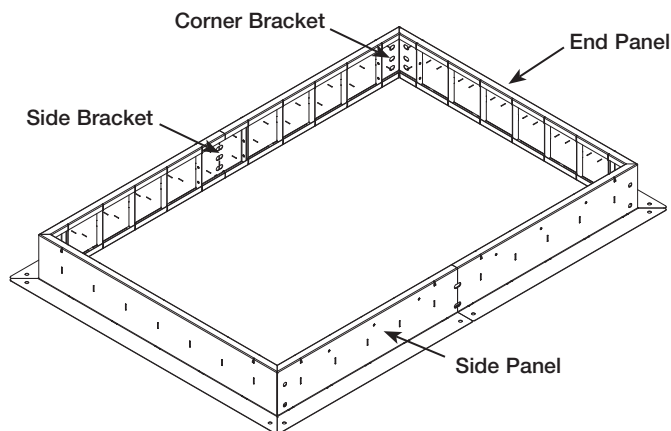

#### Fan Bypass Air Plenum (BAP) Section\*

Description	Number of Fans	Quantity
End Panel		2
Corner Bracket		4
Side Panel	one fan two fans three fans	1 2 3
Center T-Bracket	one fan two fans three fans	0 1 2
M-Wall Bracket	one fan two fans three fans	1 2 2
Center Support Bracket	one fan two fans three fans	0 1 2

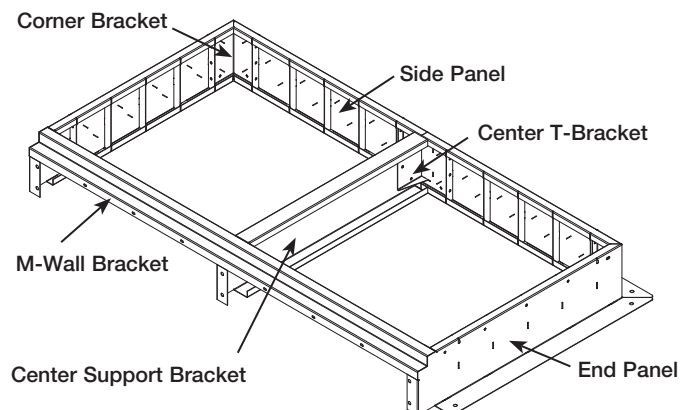

#### NOTE

Shipping with these assembly instructions are parts and subassembly drawings which provide dimensions and quantities required.

\*Image shown is a representative drawing. Actual curb for bypass air plenum section may have additional pieces, depending on quantity of fans. Image is for a two fan system.

## NOTE

The side and end panels, and corner brackets between the two sections are differentiated from each other by the overall height. The panels and brackets are 1-1/2 inches (38mm) higher for the bypass air plenum section than ERS plenum section.

## Hardware and Miscellaneous Items

- 5/16 x 1-1/2 316 SS bolt, lock and flat washer assemblies
- 1/2 x 1-1/2 316 SS bolt, 1/2 flat (qty 2) washer, 3/4 flat (qty 2) washer, lock washer and nut assemblies
- 5/16 x 1-inch moly coat 316 SS bolts, rubberized washer and lock washer assemblies
- Caulk
- Foam insulation
- Insulation clips

## Assembly Instructions for ERS Plenum Curb

Curb for the ERS plenum consists of four sides with the fourth side support against the Vektor fan bypass air plenum.

### Side Panel(s) Assembly

Examine the four side panel pieces. Two panels have additional bolt holes at the corner end. Only matching side panels are to be secured together. **Location of holes depends on size and quantities of fans for this system.**

ERS Side Panel without additional corner holes

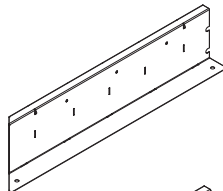

ERS Side Panel with additional corner holes

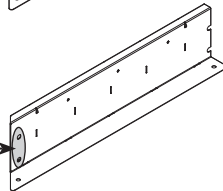

With two matching side panel pieces, set in an upright position resting on roof flashing. Butt flat edges of side panels together with mitered edge towards outside. Take one side bracket and slide into each side panel. Secure the pieces together using the 1-inch moly coat SS bolt assemblies. Bolts are to be tightened into the nut zerks. The insulation in all of the brackets (side, corner and center T-bracket) has not been fully secured so that it can be removed to make fastening the moly coat bolt assemblies easier. After tightening bolts, and replacing insulation if it was removed, secure insulation in place using the insulation clips.

Take the two remaining matching side panels and connect using same procedure.

### End Panel to Side Panel(s) Assembly

With side panel assembly complete, take either end panel and set in an upright position, resting on roof flashing, with mitered edge butted up against side panel assembly corner miter. Take one corner bracket and insert into side panel. Then insert into the end panel. Secure to each panel piece using 1-inch moly coat SS bolt assemblies and same method as used in attaching the side brackets as before.

Repeat the procedure connecting remaining end panel to the assembly using remaining corner brackets and fastener assemblies.

# Assembly Instructions for Vektor Fan Bypass Air Plenum (BAP) Curb

## M-Wall to ERS Plenum Curb Section

To the ERS plenum side panel assembly with extra holes, align M-wall bracket to be centered on side panel assembly and orientated with flat side of the bracket up.

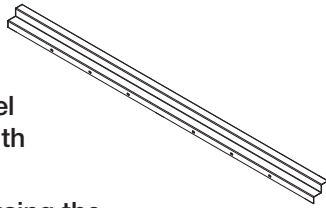

Attach the M-wall bracket using the 5/16 x 1-inch moly coat 316 SS bolt assemblies. *May be more than one piece.*

## End Panel(s) Attachment

The end panels for Vektor fan BAP curb section each have one flanged edge. The flanged edge is secured to the ERS plenum curb section utilizing the additional bolt holes located in the side panels. Set end panel piece in upright position, resting on roof flashing and the flanged edge flush to the ERS side panel. Align the holes between the side panel and the flange. Attach using the 1/2 x 1-1/2 316 SS bolt and washers.

Repeat the procedure connecting remaining end panel to other side panel or ERS curb assembly.

## Center Support Attachment

The center support has one flanged edge. The flanged edge is to be secured to the M-wall bracket and ERS plenum side panel. Set center support in upright position, resting on roof flashing and flush ERS plenum curb side panel and M-wall bracket. Align the holes between the side panel and the flange. Attach using the 1/2 x 1-1/2 316 SS bolt and washers and a 5/16 x 1-inch moly coat bolt assembly to the M-wall bracket.

## Center T-Bracket to Center Support Panel

Vektor fan BAP center T-bracket is to be connected to center support panel. This will only fit in one orientation. Place center T-bracket into position and secure with 1-inch moly coat SS bolt assemblies and use the same method as used in attaching the other side and corner brackets.

## Side Panel(s) Connection

After center T-bracket and end panels have been secured, the side panels can be installed. Only one end of each side panel is able to be secured to the center T-bracket and the other only to the corner joint with the end panels. Take either side panel and set into upright position, resting on roof flashing and between T-bracket flange and end panel's corner. Use 5/16 x 1-inch moly coat bolt fastener assemblies and secure side panel into position.

Repeat the procedure in connecting remaining side panel to T-bracket and end panel.

## Caulking

Apply the caulk to help seal any joints between the curb panels.

## Foam Insulation Tape

Provided foam insulation tape is to be applied to the top surface of all roof curb panels. Foam insulation is to be applied prior to setting the ERS plenum and Vektor fan BAP. (Foam insulation for the BAP is shipped with the BAP). Care should be taken to apply the foam insulation so that there are no gaps or spaces between pieces.

## Vektor Fan Bypass Air Plenum Attachment

The 5/16 x 1-1/2 316 SS bolt assemblies provided in the panels of the Vektor fan BAP section are for mounting the BAP to the curb. Assemblies will need to be removed prior to setting the fan BAP onto the curb. Refer to the Vektor-ERS Installation, Operation and Maintenance Manual for the procedure on how the plenum sections are to be mounted to the ERS roof curb.

### NOTE

Relative orientation of assembled curb to the standard duct connection locations for the plenum mounting on the roof curb.

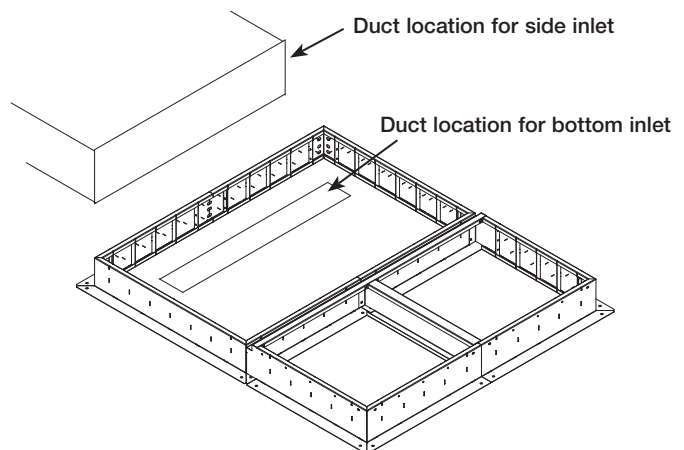

## Assembly Instructions

**READ THROUGH THESE INSTRUCTIONS PRIOR TO STARTING ASSEMBLY.**

### Document Instructions

Use Document #1016916 with fastener kits 915007 – 915013. These kits are to be used with the Vektor-M Energy Recovery System (ERS) curbs. The fasteners contained within the kit are to be used to assemble and join the bypass air plenum (BAP) and ERS sections. Use images located within this document to locate the position of the fasteners on the unit.

### Assembly Instructions for Curb Panels and Brackets (Fastener Kits 915007 – 915010)

1. See Greenheck Document #474117 (Fan Plenum Curb Assembly) for full installation instructions.
2. Fastener kit includes fasteners required to assemble BAP and ERS sections by joining curb panels with bolt in brackets (corner, side, "T", and M-wall). Depending on configuration, some kits may have extra hardware when completed.
3. See images below to locate bolt holes. Install moly-coated 316 stainless steel bolts through curb panels into brackets. Insulation pieces may need to be removed.
4. When curb is fully assembled, fasten insulation back into place using fastener kit 915014.

#### Tools Required

- Cordless drill (electric or pneumatic)
- 1/2 inch nut setter
- 1/2 inch wrench

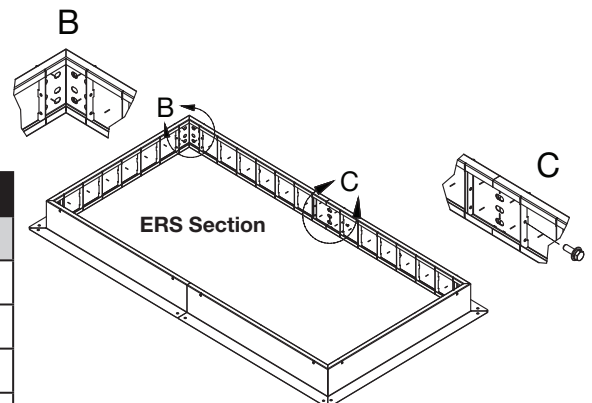
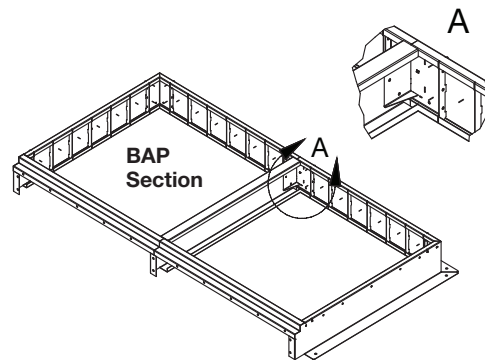
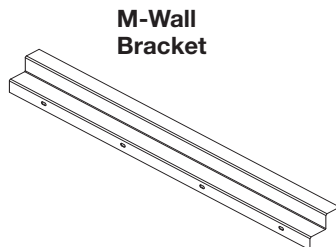
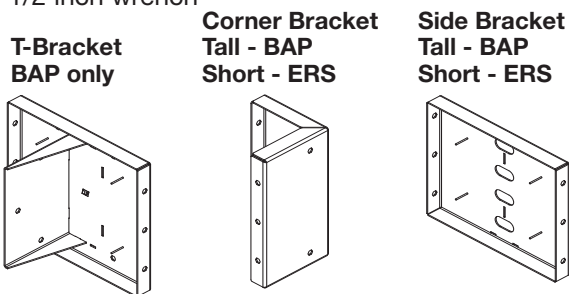
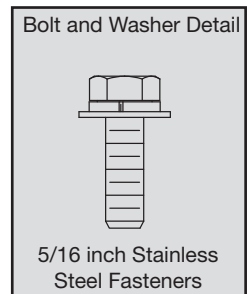

#### FASTENER KIT – BAP AND ERS CURB SECTIONS

Kit #	Part Description	Part #	Quantity
915007	CS,HH,.,313-18X1,SS,316,MOLY	416511	56
915008			72
915009			84
915010			98
	Assembly Instructions	1016916	1

## Assembly Instructions for BAP Section to ERS Section

### (Fastener Kits 915011 – 915013)

1. See Greenheck Document #474117 (Fan Plenum Curb Assembly) for full installation instructions.
2. The fastener kit includes hardware to bolt together the BAP section to the ERS section as one unit.
3. See image to the right to locate bolt holes. Install 316 stainless steel bolts through brackets of ERS section into BAP section. Some insulation may need to be removed.
4. When curb is fully assembled, fasten insulation back into place using fastener kit 915014.

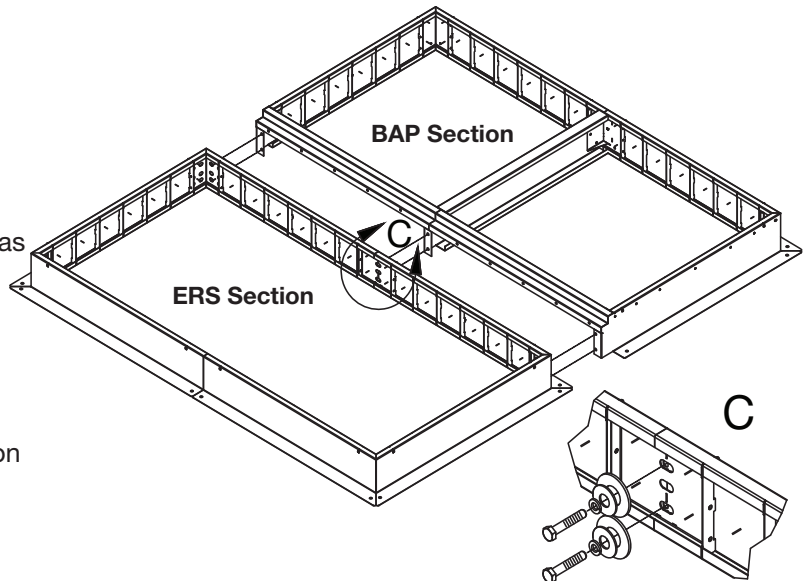

### Tools Required

- Cordless drill (electric or pneumatic)
- 3/4 inch nut setter
- 3/4 inch wrench

#### FASTENER KIT 915011 – JOIN 1X1 BAP AND ERS SECTIONS

Part Description	Part #	Quantity
SCR,CS,HH,.5-13X1.5,SS,316	415782	4
NUT,HEX,.5-13,SS,316	415802	4
WSHR,LOCK,SPLIT,.5,SS,316	415809	4
WSHR,FLAT,.75X.1X.812X1.75,SS,316	415830	8
WSHR,FLAT,.05X.06X.531X1.25,SS,316	415803	8

#### FASTENER KIT 915012 – JOIN 2X1 BAP AND ERS SECTIONS

Part Description	Part #	Quantity
SCR,CS,HH,.5-13X1.5,SS,316	415782	6
NUT,HEX,.5-13,SS,316	415802	6
WSHR,LOCK,SPLIT,.5,SS,316	415809	6
WSHR,FLAT,.75X.1X.812X1.75,SS,316	415830	12
WSHR,FLAT,.05X.06X.531X1.25,SS,316	415803	12

#### FASTENER KIT 915013 – JOIN 3X1 BAP AND ERS SECTIONS

Part Description	Part #	Quantity
SCR,CS,HH,.5-13X1.5,SS,316	415782	8
NUT,HEX,.5-13,SS,316	415802	8
WSHR,LOCK,SPLIT,.5,SS,316	415809	8
WSHR,FLAT,.75X.1X.812X1.75,SS,316	415830	16
WSHR,FLAT,.05X.06X.531X1.25,SS,316	415803	16

#### Bolt and Washer Detail

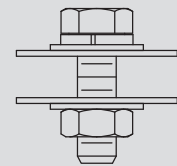

1/2 inch Bolt  
 1/2 inch Lock Washer  
 1/2 inch Flat Washer (2)  
 3/4 inch Flat Washer (2)  
 1/2 inch Nut

## Assembly Instructions

**READ THROUGH THESE INSTRUCTIONS PRIOR TO STARTING ASSEMBLY.**

### Document Instructions

Use Document #1016917 with fastener kit 915014. This kit is to be used with the Vektor-M Energy Recovery System (ERS) curbs. The insulation clips provided are to secure insulation pieces to the roof curb panels when assembly of curb is complete. Use images located within this document to locate the position of the fasteners on the unit.

### Assembly Instructions

1. See Greenheck Document #474117 (Fan Plenum Curb Assembly) for full installation instructions.
2. The fastener kit includes insulation clips to secure insulation to curb panels. In some cases, pieces of insulation may need to be removed prior to bolting in brackets. When all brackets are installed and the insulation is replaced, the clips can be pushed onto insulation pins. Do not install clips until curb is fully assembled.
3. See image below to locate which insulation pieces require insulation clips to be field installed. Image shown is representation, actual curb panel may vary.

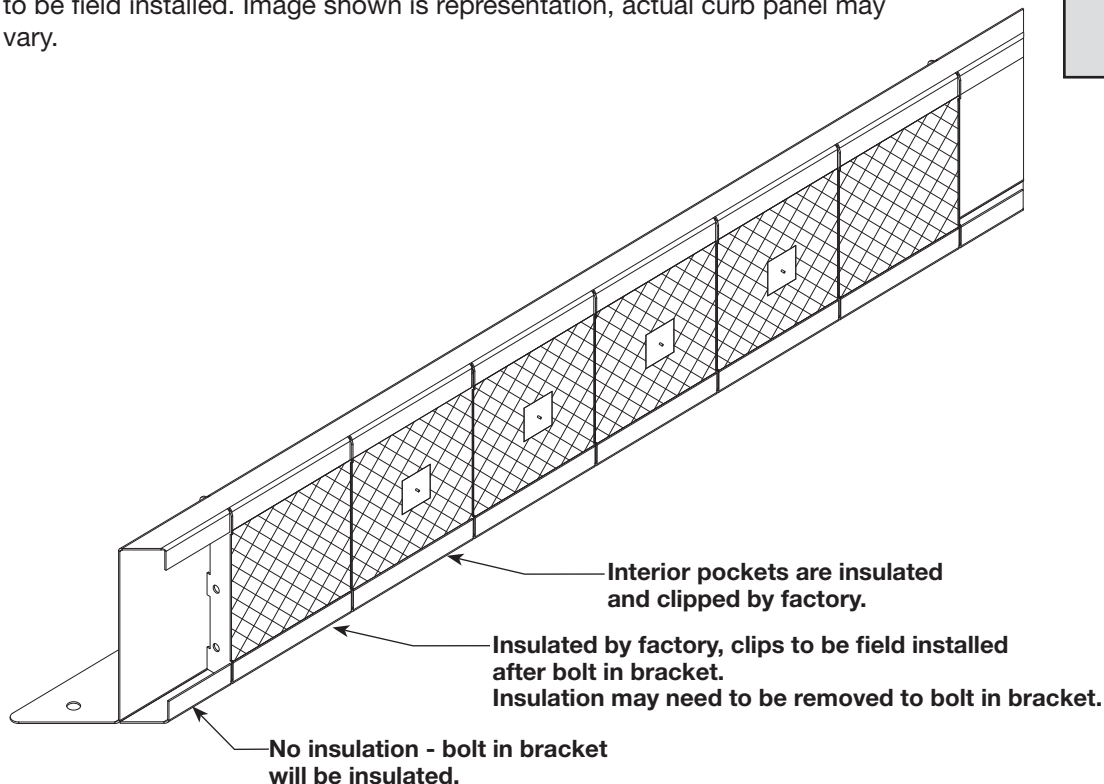
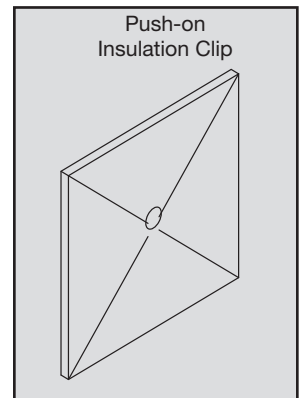

### FASTENER KIT 915014 – ERS CURB, INSULATION CLIPS

Part Description	Part #	Quantity
CLW,INSUL,1.5X1.5,GALV.	415660	36
Assembly Instructions	1016917	1

## Assembly Instructions

**READ THROUGH THESE INSTRUCTIONS PRIOR TO STARTING ASSEMBLY.**

### Document Instructions

Use Document #1016918 with fastener kits 915003-915006. This kit is to be used with the Vektor-ERS (Energy Recovery System). The fasteners contained within the kit are to be used to attach the plenum assembly to the roof curb. Use images located within this document to locate the position of the fasteners on the unit.

### Assembly Instructions

1. See Greenheck Document #474118 (Installation, Operation and Maintenance Manual: Energy Recovery System) for full bypass air plenum (BAP) and ERS installation instructions.
2. See image below to locate bolt holes. Install moly-coated 316 stainless steel bolts (provided) in all holes in plenum cap.
3. The number of fasteners per side may change with fan size and configuration (2x1 system, 3x1 system, etc.). Depending on configuration, some kits may have extra hardware when complete.

### Tools Required

- Cordless drill
- 1/2 inch nut setter

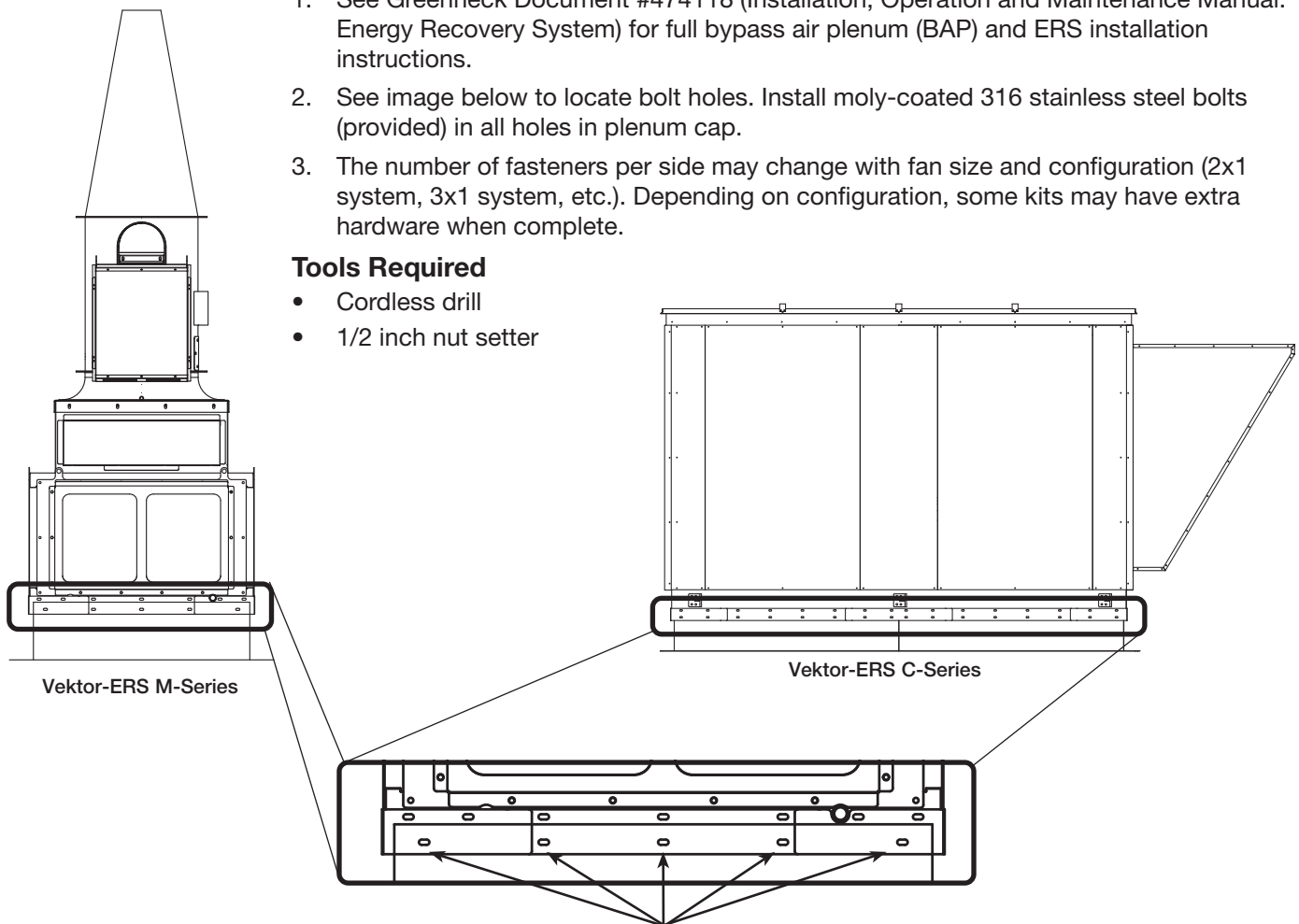

**Install supplied bolts through  
BAP skirting into roof curb.**

### FASTENER KIT – FAN ASSEMBLY TO ROOF CURB\*

Kit #	Part #	Part Description
915003 - 915006	416980	CS,HH,.313-18X2,SS,316,MOLY

\*Kits will be duplicated depending on configuration of system.



## Assembly Instructions

**READ THROUGH THESE INSTRUCTIONS PRIOR TO STARTING ASSEMBLY.**

### Document Instructions

Use Document #1032090 with fastener kit 918440. These kits are to be used with the Vektor-ERS (Energy Recovery System). The fasteners contained within the kit are to be used to join the interior sections of a modular roof curb. Use the images located within this document to locate the position of the fasteners on the unit.

### Assembly Instructions

1. See Greenheck Document #464652 (Installation, Operation and Maintenance Manual: Vektor-MD, Vektor-MH and Vektor-MS) for full fan installation instructions.
2. The fastener kit includes fasteners for one interior section connection. If the fan array includes multiple interior section connections, multiple fastener kits will be supplied.
3. See image to the right to locate bolt holes. Install moly-coated 316 stainless steel screws (provided) in all holes in roof curb interior.

### Tools Required

- Cordless drill
- 9/16 inch nut setter
- 9/16 inch wrench

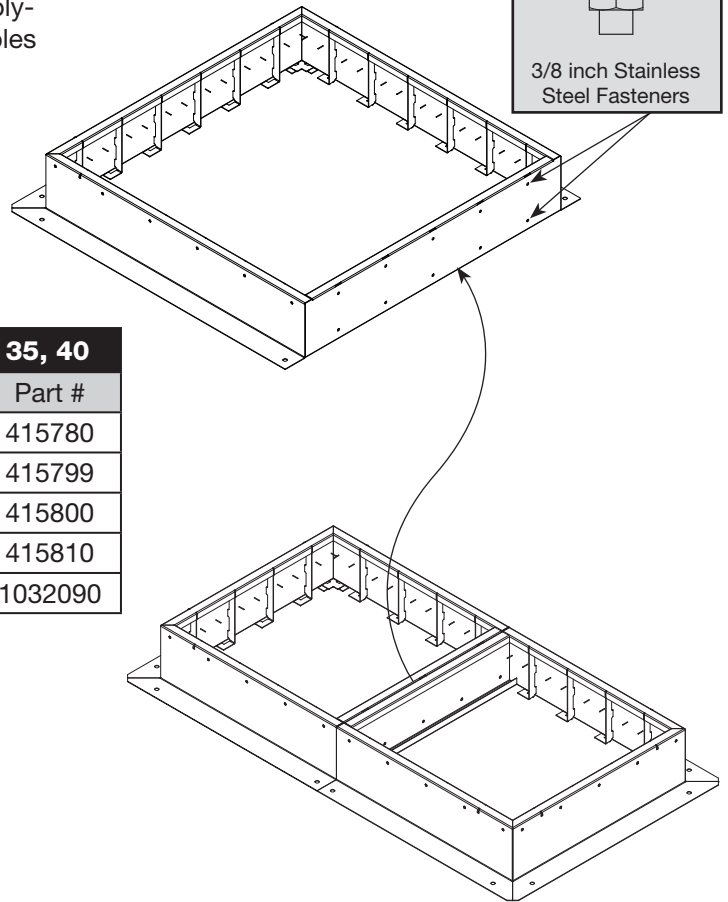
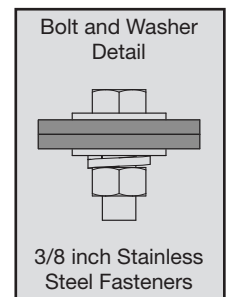

### FASTENER KIT 918440 – VEKTOR-ERS SIZE 25, 35, 40

Part Description	Part #
CS,HH,.375-16X1.25,SS,316,MOLY	415780
NUT,HEX,.375-16,SS,316	415799
WSHR,FLAT,.05X.406X.875,SS,316	415800
WSHR,LOCK,SPLIT,.375,SS,316	415810
Assembly Instructions	1032090

## Maintenance Log

---

Date \_\_\_\_\_ Time \_\_\_\_\_ AM/PM

Notes: \_\_\_\_\_  
\_\_\_\_\_  
\_\_\_\_\_  
\_\_\_\_\_

Date \_\_\_\_\_ Time \_\_\_\_\_ AM/PM

Notes: \_\_\_\_\_  
\_\_\_\_\_  
\_\_\_\_\_  
\_\_\_\_\_

Date \_\_\_\_\_ Time \_\_\_\_\_ AM/PM

Notes: \_\_\_\_\_  
\_\_\_\_\_  
\_\_\_\_\_  
\_\_\_\_\_

Date \_\_\_\_\_ Time \_\_\_\_\_ AM/PM

Notes: \_\_\_\_\_  
\_\_\_\_\_  
\_\_\_\_\_  
\_\_\_\_\_

Date \_\_\_\_\_ Time \_\_\_\_\_ AM/PM

Notes: \_\_\_\_\_  
\_\_\_\_\_  
\_\_\_\_\_  
\_\_\_\_\_

Date \_\_\_\_\_ Time \_\_\_\_\_ AM/PM

Notes: \_\_\_\_\_  
\_\_\_\_\_  
\_\_\_\_\_  
\_\_\_\_\_

Date \_\_\_\_\_ Time \_\_\_\_\_ AM/PM

Notes: \_\_\_\_\_  
\_\_\_\_\_  
\_\_\_\_\_  
\_\_\_\_\_

Date \_\_\_\_\_ Time \_\_\_\_\_ AM/PM

Notes: \_\_\_\_\_  
\_\_\_\_\_  
\_\_\_\_\_  
\_\_\_\_\_

## Our Commitment

---

*As a result of our commitment to continuous improvement, Greenheck reserves the right to change specifications without notice.*

Product warranties can be found online at [Greenheck.com](http://Greenheck.com), either on the specific product page or in the literature section of the website at [Greenheck.com/Resources/Library/Literature](http://Greenheck.com/Resources/Library/Literature).

AMCA Publication 410-96, Safety Practices for Users and Installers of Industrial and Commercial Fans, provides additional safety information. This publication can be obtained from AMCA International, Inc. at [www.amca.org](http://www.amca.org).

