

Model: XG-H4004-AF-1 Horizontal Blades Front - Flush Surface Mount
XG-H4004-AF-6 Horizontal Blades Front - T-Bar Lay In

XG-H4004-AF-1 - Flush Surface Mount

Face View

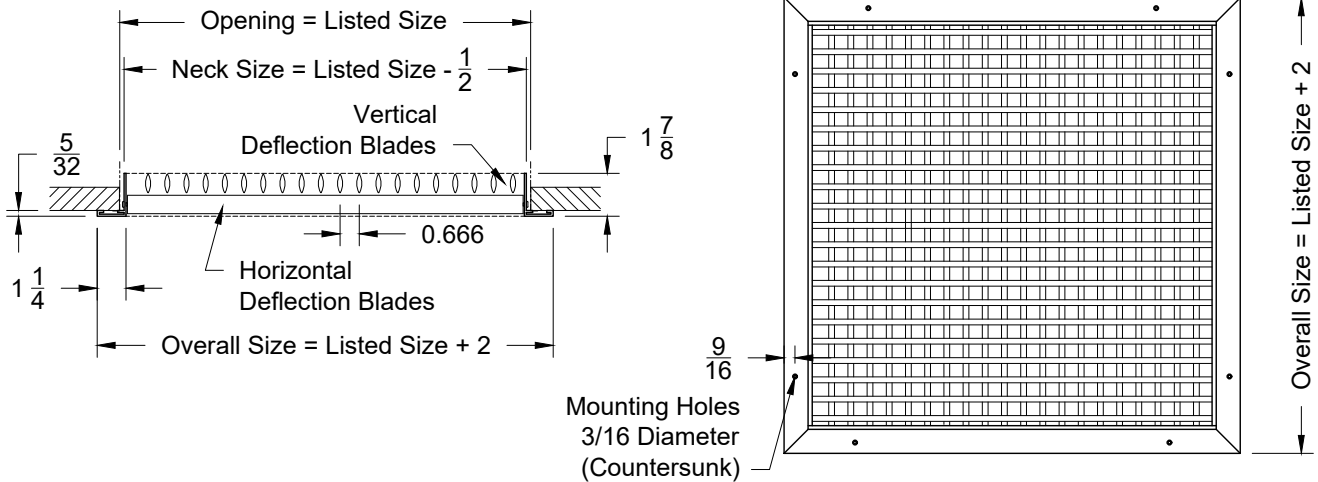

XG-H4004-AF-6 - T-Bar Lay-In

Face View

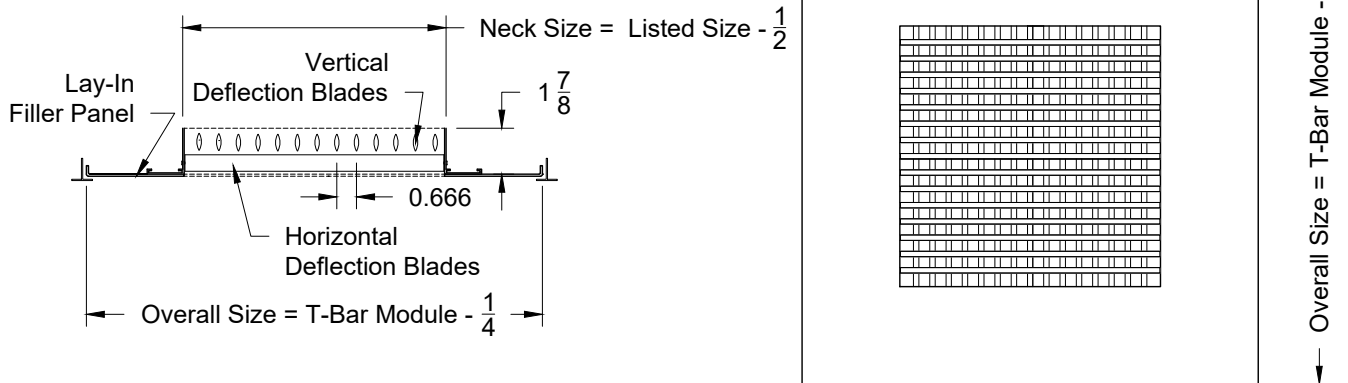

Note: This product complies with NFPA 90A-18 standard 4.3.7.3.2 and 4.3.8.3.2 and is constructed with openings through which a 1/2" sphere can not pass.

1. Available Finishes	2. Available Accessories	3. Available Options	4. Construction Details
Standard Finish: 01 White Finish 24 Mill Finish Optional Finish 02 Satin Silver 03 Black 28 Custom Color	XG-OBDA - Steel Opposed Blade Damper XG-OBDA - Aluminum OBD XG-L9 - Equalizing Grid XG-PF - Plaster Frame XG-TBPF - T-Bar Plaster Frame XG-TR - Square to Round Transition XG-TR-Deep - Deep Transition XG-LIPF - Lay-In Plaster Frame	XG-IS - Insect Screen XG-FGBP - Fiberglass Backpan XG-NSH - No Screw Holes	<ul style="list-style-type: none"> • Odd/Fractional Sizes Available • Oversized Units made in multiple sections • Largest single section is 48x48 • Mullion strips provided for joining units in field • Extruded Aluminum Airfoil blades.

All Dimensions ±1/16"

Model: XG-V4004-AF-1 Vertical Blades Front - Flush Surface Mount
 XG-V4004-AF-6 Vertical Blades Front - T-Bar Lay In

XG-V4004-AF-1 - Flush Surface Mount

Face View

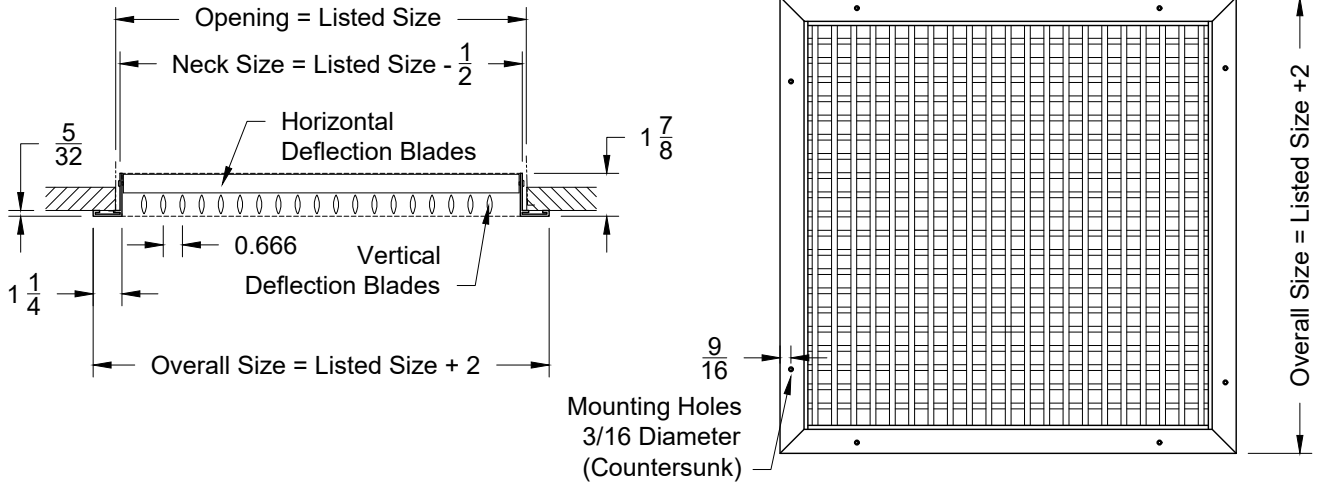

XG-V4004-AF-6 - T-Bar Lay In

Face View

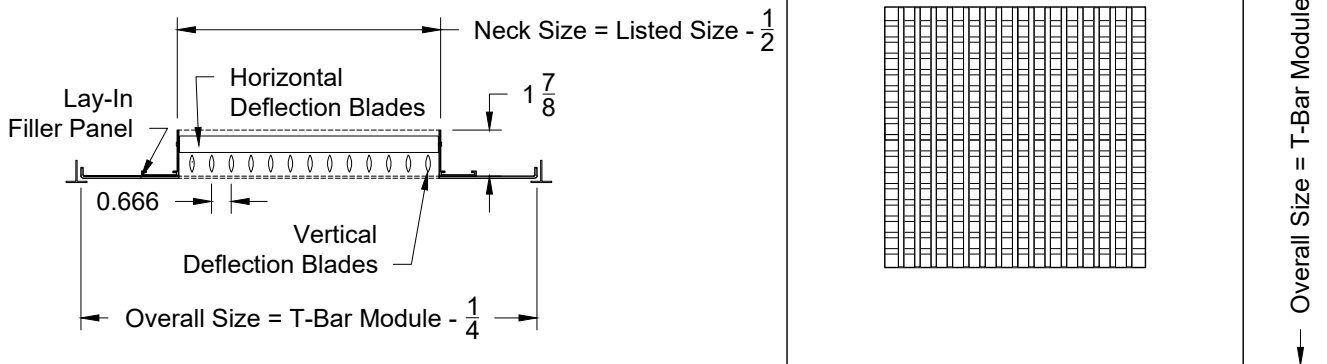

Note: This product complies with NFPA 90A-18 standard 4.3.7.3.2 and 4.3.8.3.2 and is constructed with openings through which a 1/2" sphere can not pass.

1. Available Finishes	2. Available Accessories	3. Available Options	4. Construction Details
Standard Finish: 01 White Finish 24 Mill Finish Optional Finish 02 Satin Silver 03 Black 28 Custom Color	XG-OBDD - Steel Opposed Blade Damper XG-OBDA - Aluminum OBD XG-L9 - Equalizing Grid XG-PF - Plaster Frame XG-TBPF - T-Bar Plaster Frame XG-TR - Square to Round Transition XG-TR-Deep - Deep Transition XG-LIPP - Lay-In Plaster Frame	XG-IS - Insect Screen XG-FGBP - Fiberglass Backpan XG-NSH - No Screw Holes	<ul style="list-style-type: none"> Odd/Fractional Sizes Available Oversized Units made in multiple sections Largest single section is 48x48 Mullion strips provided for joining units in field Extruded Aluminum Airfoil blades.

All Dimensions $\pm 1/16"$