

Installation, Operation and Maintenance Manual
XG-6600 Linear Slot Diffuser



Installation, Operation and Maintenance Manual

Please read and save these instructions for future reference. Read carefully before attempting to assemble, install, operate or maintain the product described. Protect yourself and others by observing all safety information. Failure to comply with these instructions will result in voiding of the product warranty and may result in personal injury and/or property damage.



Table of Contents

Getting Started	2
Model Nomenclature	3
Border Types – Quick Reference Guide	3
Border Types – Dimensional Drawings	4 - 6
End Border Types	7
Installation:	
Concealed Surface Mount (-12-1 Frame)	7 - 8
Concealed Tape and Spackle Mount (-52-1 Frame).	9
Concealed Spline Mount (-22-73 Frame)	9 - 11
Operation:	
Pattern Controller Adjustment	11
Maintenance:	
General Maintenance	12

Getting Started/Model Nomenclature

1. Before starting, inspect all shipping boxes for visible damage. If any visible damage is found, note it on the BOL and contact your local Greenheck Representative.
2. If you decide to keep the shipment, take all linear diffusers out of the shipping boxes, and inspect for any manufacturing flaws or hidden damage. If anything is found, contact your local Greenheck Representative.
3. Once all product is accounted for in acceptable condition locate any mounting hardware (if included) and be sure to keep this hardware with the applicable diffuser.
4. Referring to the model nomenclature breakdown and the Table of Contents, proceed to the appropriate page within this IOM to begin installation.

Model Nomenclature

XG-6600 Series Linear Slot Diffusers

Product Family							Return Model <i>Optional</i>	Frame Type	Border Type	Length in Inches	# of Slots	End Types	Finish				
X	G	-	6	6	5	0	R	-	1	1	-	6	108	x	3	1EB	20
							50 = 0.50" Slot Width 75 = 0.75" Slot Width 10 = 1" Slot Width 15 = 1.5" Slot Width	11-1 = Face Screw Surface Mount - No Hardware 12-1 = Surface Mount With Hardware (Concealed Mount) 10-6 = 1-1/8" Border Lay-In No Hardware 12-6 = 1-1/8" Border Lay-In With Hardware 20-6 = 3/4" Border Lay-In No Hardware 22-6 = 3/4" Border Lay-In With Hardware 22-73 = 3/4" Border Concealed Spline With Hardware - Plaster Frame 22-74 = 3/4" Border Concealed Spline With Hardware - Plaster/Wall Frame 22-75 = 3/4" Border Concealed Spline With Hardware - Wall Frame 30-6 = 1/2" Border Lay-In No Hardware 32-6 = 1/2" Border Lay-In With Hardware 40-7 = 9/16" Border Concealed Spline No Hardware 40-8 = 9/16" Border Lay-In - Drop Face No Hardware 40-9 = 9/16" Border Lay-In - Narrow Tee No Hardware 42-7 = 9/16" Border Concealed Spline With Hardware 42-8 = 9/16" Border Lay-In - Drop Face With Hardware 42-9 = 9/16" Border Lay-In - Narrow Tee With Hardware 50-1 = Tape and Spackle (Mud-In) Mount No Hardware 52-1 = Tape and Spackle (Mud-In) Mount With Hardware	Length of Linear in Inches	Quantity of Slots	1EB = 1 End Border and 1 Open End 1EC = 1 End Cap and 1 Open End 2EB = 2 End Borders (both ends have borders) 2EC = 2 End Caps (both ends have caps) OO = 2 Open Ends (both ends are open) MM = Mitered Ends (-50,-52 Frame Style Only) MO = 1 Mitered End 1 Open End (-50,-52 Frame Style Only)	20 = White Frame with Black Pattern Controller 21 = Clear Frame with Black Pattern Controller 03 = Black Frame and Black Pattern Controller					

Border Types - Quick Reference Guide

Frame	Application						Hardware		Border				
	Surface Mount	Lay-In	Drop Face	Narrow Tee	Concealed Spline	Tape and Spackle	With	Without	1/2"	9/16"	3/4"	1-1/8"	1-13/16"
XG-6600-11-1	X							X				X	
XG-6600-12-1	X						X					X	
XG-6600-10-6		X						X				X	
XG-6600-12-6		X					X					X	
XG-6600-20-6		X						X			X		
XG-6600-22-6		X					X				X		
XG-6600-22-73					X			X			X		
XG-6600-22-74					X			X			X		
XG-6600-22-75					X			X			X		
XG-6600-30-6		X						X	X				
XG-6600-32-6		X					X		X				
XG-6600-40-7					X			X		X			
XG-6600-40-8			X					X		X			
XG-6600-40-9				X				X		X			
XG-6600-42-7					X		X			X			
XG-6600-42-8			X				X			X			
XG-6600-42-9				X			X			X			
XG-6600-50-1						X		X					X
XG-6600-52-1						X	X						X

Border Types – Dimensional Drawings

Surface Mount

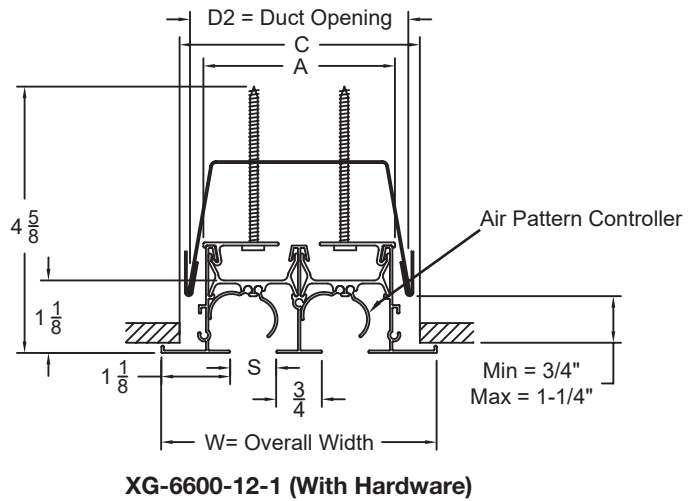
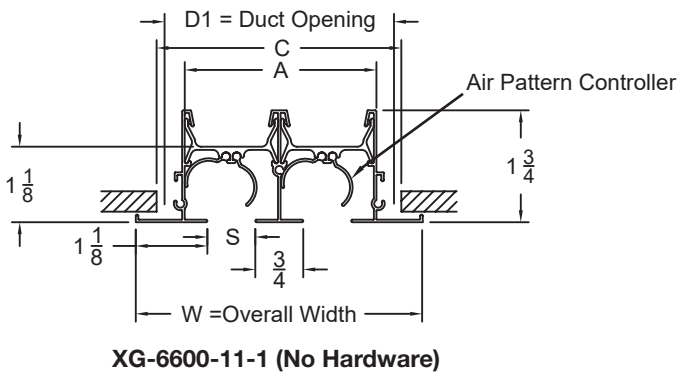

Lay-In Mount – 1-1/8" Border

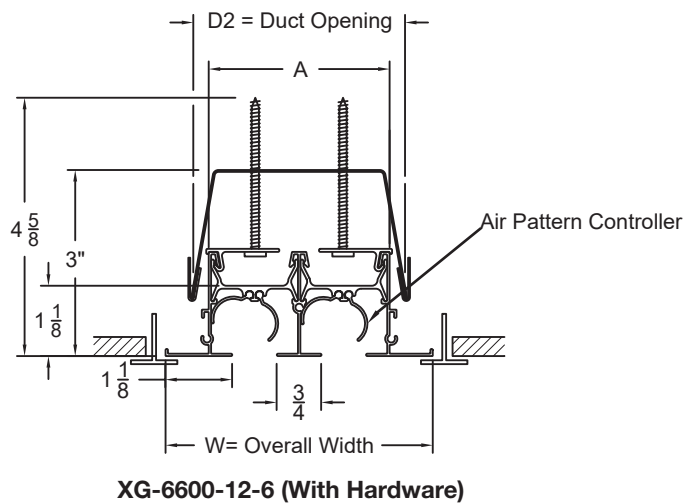
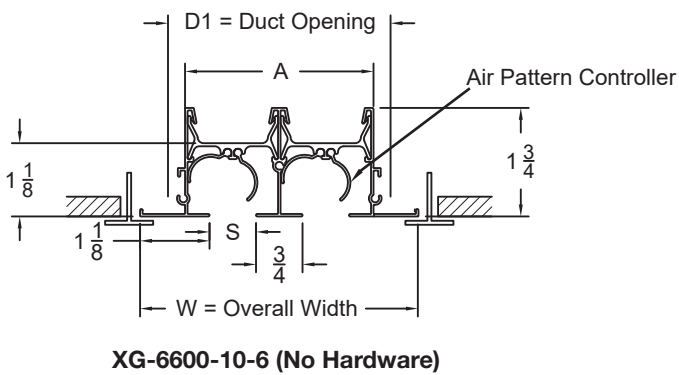

Lay-In Mount – 3/4" Border

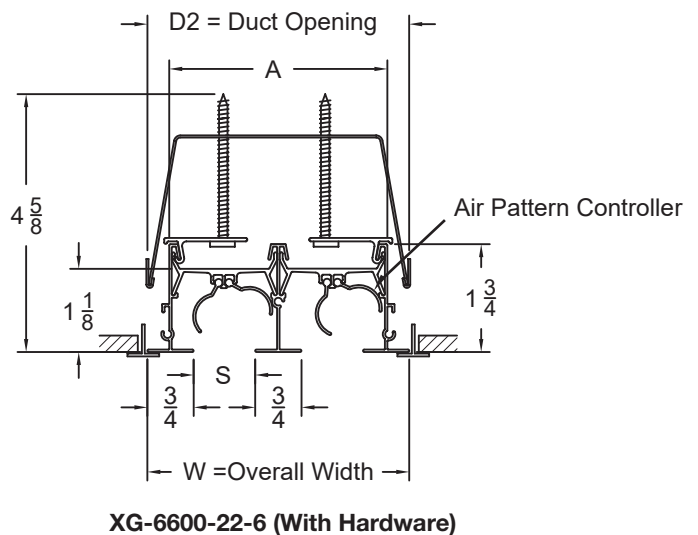
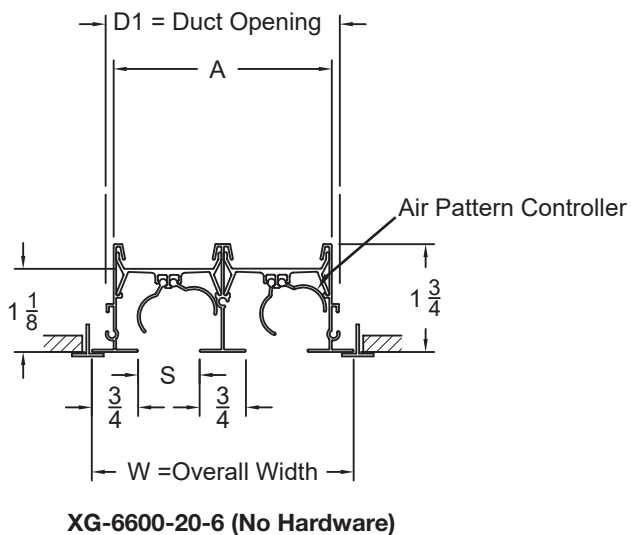

Border Types – Dimensional Drawings (continued)

Lay-In Mount – 1/2"

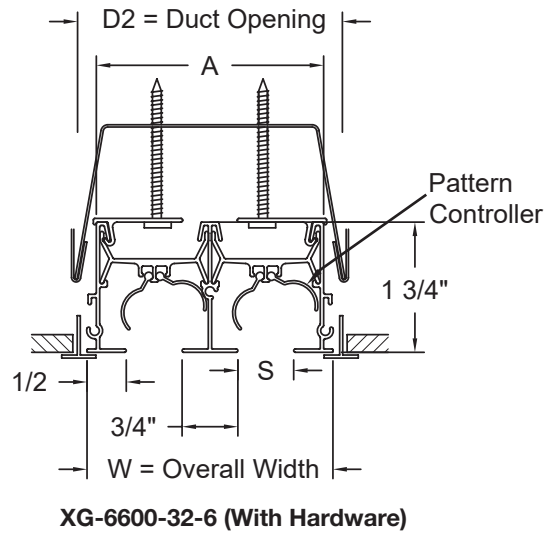
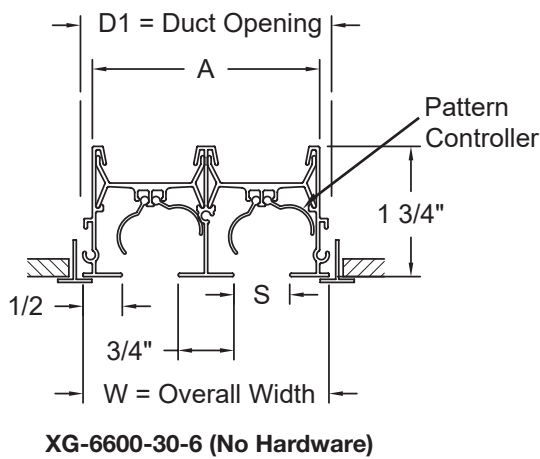

Lay-In Mount – 9/16" Border Drop Face

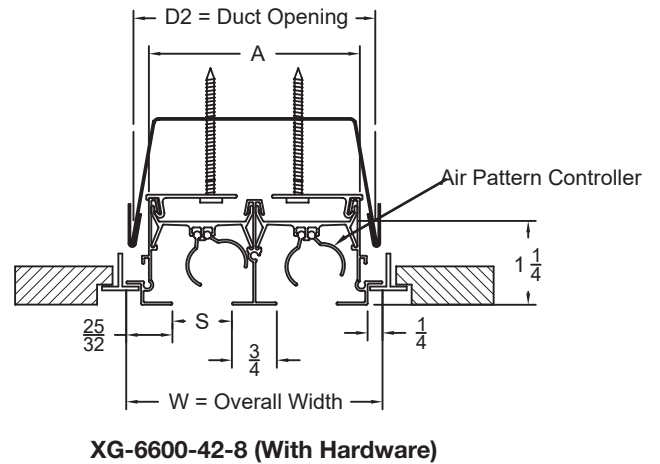
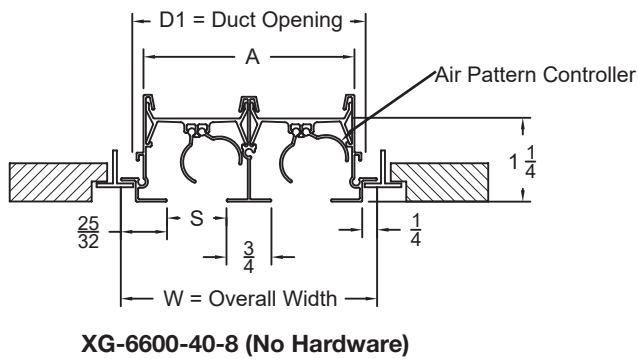

Lay-In Mount – 9/16" Border Narrow Tee

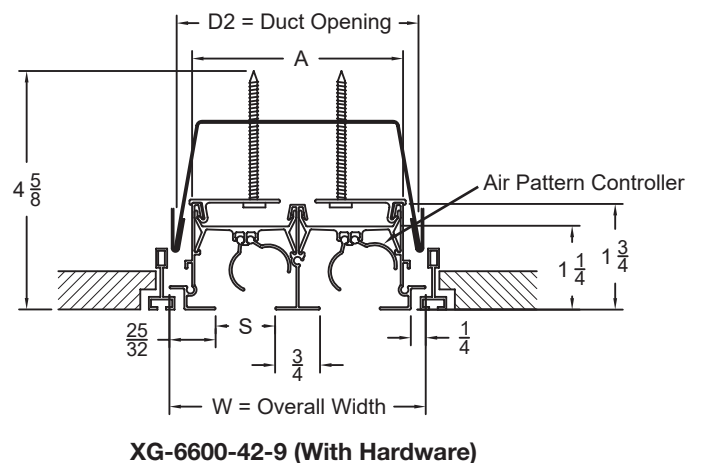
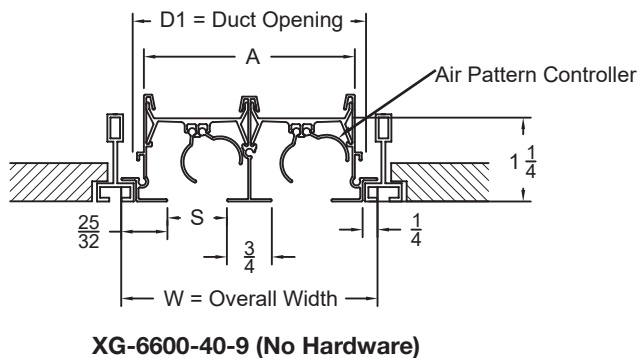

Border Types – Dimensional Drawings (continued)

Concealed Spline Mount – 3/4" Border

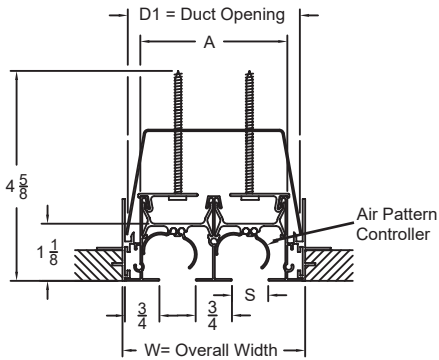

XG-6600-22-73 (Plaster Both Sides)

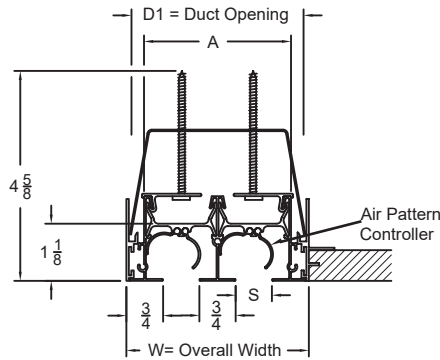

XG-6600-22-74 (Plaster / Wall Frame)

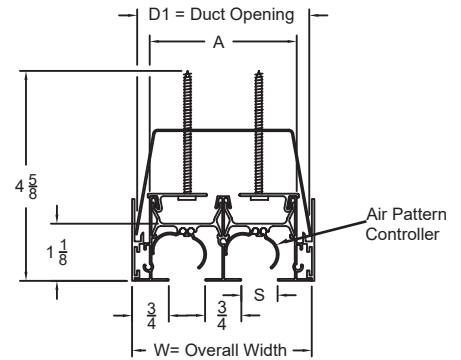

XG-6600-22-75 (Wall Frame)

Concealed Spline Mount – 9/16" Border

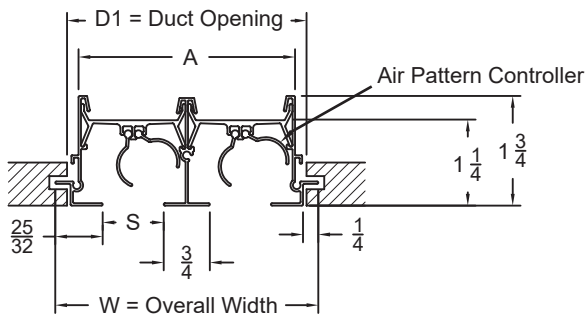

XG-6600-40-7 (No Hardware)

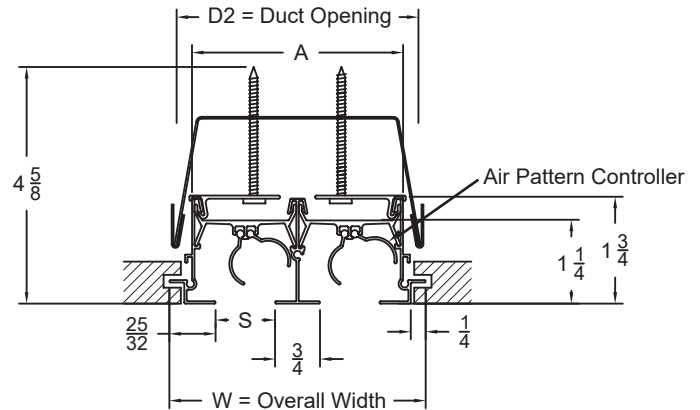

XG-6600-42-7 (With Hardware)

Tape and Spackle (Mud-In) Mount

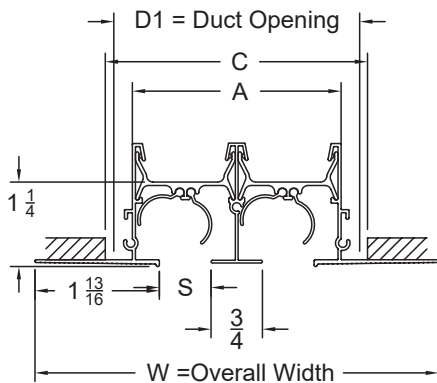

XG-6600-50-1 (No Hardware)

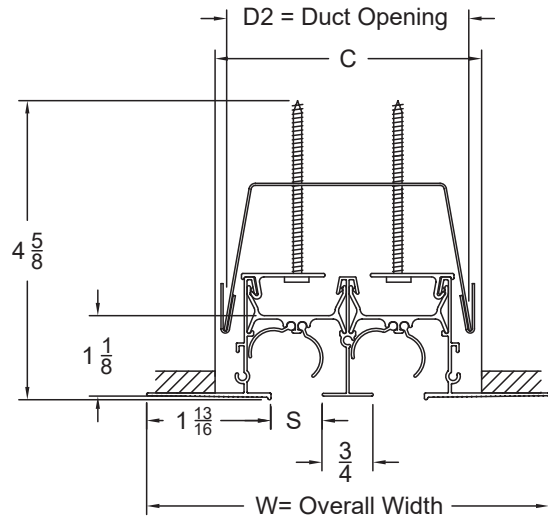

XG-6600-52-1 (With Hardware)

End Border Types

Surface Mount and Lay-In Options:

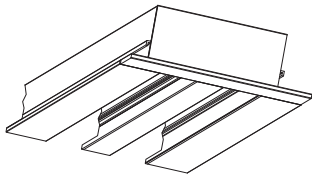

End Border (EB)

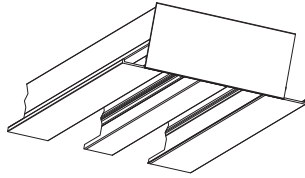

End Cap (EC)

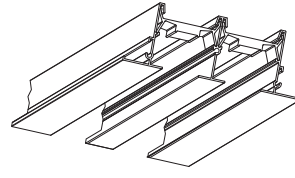

Open End (O)

Concealed Spline Options:

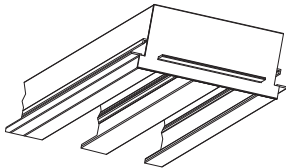

End Border (EB)

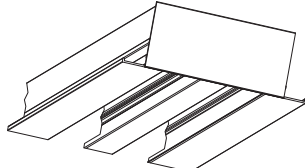

End Cap (EC)

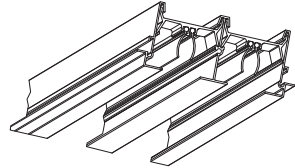

Open End (O)

Tape and Spackle (Mud-In):

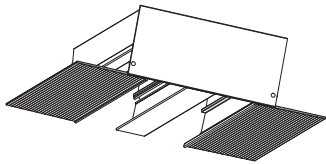

End Cap (EC)

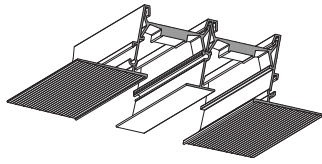

Open End (O)

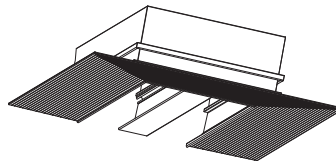

Mitered Ends (M)

Installation Instructions for Drywall Surface Mount Applications (Concealed Mount -12-1 Tape and Spackle 52-1 Frame)

This section applies to Greenheck model XG-6600-12-1 and XG-6600-52-1 specifically. The below can be used as a guideline to install other Greenheck XG-6600 frame styles that mount similarly with concealed mounting hardware in a surface mount application.

Step 1 – Mounting Hardware

- A. Locate and ensure all proper mounting brackets and screws were supplied with the linear diffuser before starting installation. See Figure 1 for a table showing how many hanger brackets are shipped with the corresponding linear lengths.

XG-6600 Linear Length	Number of Hanger Brackets
24" or less	2
> 24" to 48"	3
> 48" to 60"	4
> 60" to 96"	6

Figure 1 (Step 1A)

Step 2 – Framing the Opening

- A. Before installing drywall, an adequate frame must be constructed for the Greenheck XG-6600 Linear Slot Diffuser. This framing must be suitable to hold the weight of the diffuser (typically wood framing). The length and width of the framing depends on the length and number of slots of the linear diffuser being installed.
- B. In general, the length of the opening within the framing should be the ordered size plus $\frac{1}{2}$ " (see Figure 2) and the opening width should be the "C" dimension from the Greenheck XG-6600-11-12-1 and XG-6600-50-52-1 submittal. For convenience, we have provided the dimensional drawing (see Figure 3) and dimension table (see Figure 4) from the XG-6600-11-12-1 submittal (please note the most up-to-date information will be on the submittal).

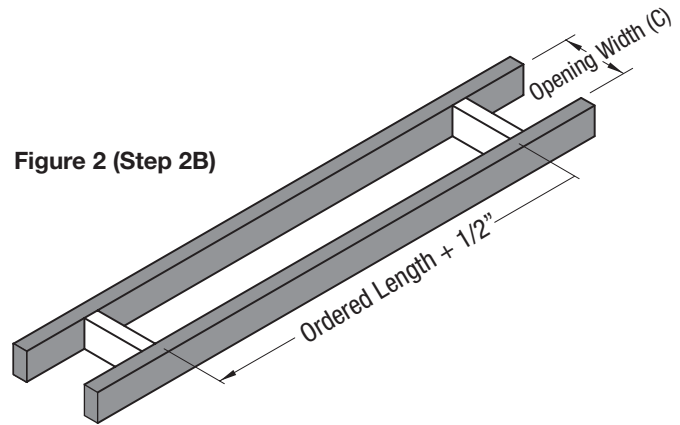

Figure 2 (Step 2B)

# of Slots	C Dimension (Inches)			
	XG-6650 (1/2" Slot)	XG-6675 (3/4" Slot)	XG-6610 (1" Slot)	XG-6615 (1-1/2" Slot)
1	1-7/8"	2-1/8"	2-3/8"	2-7/8"
2	3-1/8"	3-5/8"	4-1/8"	5-1/8"
3	4-3/8"	5-1/8"	5-3/4"	7-3/8"
4	5-5/8"	6-5/8"	7-5/8"	9-5/8"
5	6-7/8"	8-1/8"	9-3/8"	-
6	8-1/8"	9-7/8"	11-1/8"	-
7	9-3/8"	11-1/8"	12-7/8"	-
8	10-5/8"	12-5/8"	14-5/8"	-

Figure 4 (Step 2B): XG-6600-12-1 Dimension Table

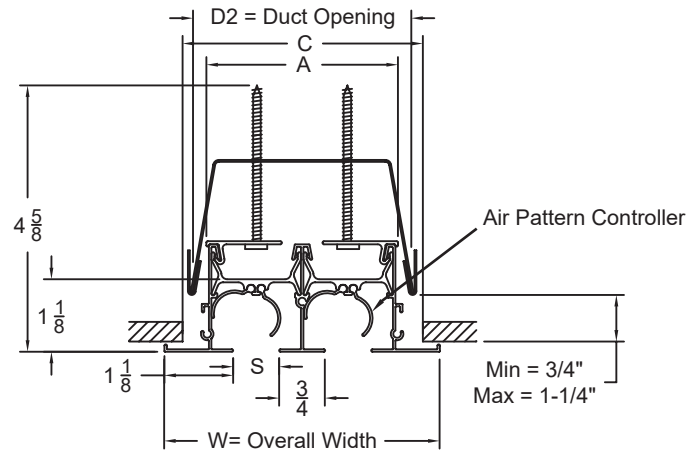

Figure 3 (Step 2B): XG-6600-12-1 Cut Section

Step 3 – Preparation for the Hanger Supports

- A. The hanger bracket hardware is meant to be installed above the plane of the sheet rock in the ceiling. Once installed above that plane, using the screws provided, you will be able to screw from the face of the diffuser and the linear diffuser will be pulled up into the opening.
- B. There are several ways to support the hanger brackets – see Figure 5.

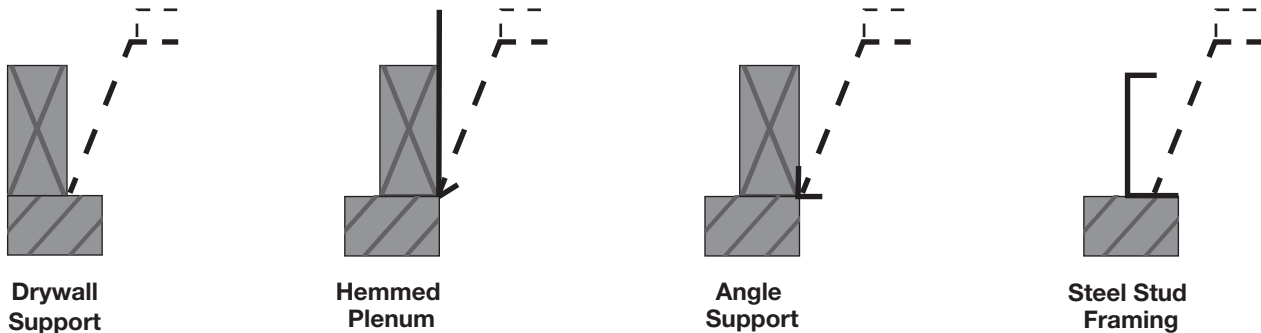

Figure 5 (Step 3B): Hanger Support Options

Step 4 – Installing Hanger Brackets

- A. To start, insert the screw through the face of the diffuser and start the screw into the hanger bracket – do not tighten all the way, only enough to be attached see Figure 5.
- B. Push all brackets up into the opening until all hanger brackets get caught on the hanger bracket support (drywall, hemmed plenum, angle, steel stud, etc.) – see Figure 6.
- C. Using a screwdriver or drill, tighten the screws to pull the linear slot diffuser up into the opening – see Figure 7.



Figure 5 (Step 4A)

Step 5 - Tape and Spackle (XG-6600-52-1 Only)

- A. Once the hanger bracket has been tightened to securely attach the 6600-52-1 unit to the ceiling, the next step is to use tape and spackle to conceal the flange.
- B. First use medium grit sand paper to rough up the drywall surface to ensure that the joint compound will adhere properly. Ensure surface of the linear is clean and free of dust.
- C. Apply a first coat of joint compound spackle to the surface of the linear's flange and surrounding border of drywall.
- D. Use drywall tape and install it around the entire perimeter of the unit. The tape should cover the aluminum perimeter flange of the linear, as well as overlap onto the drywall to ensure a smooth transition. Then apply another layer of spackle to the surface.
- E. Once the spackle is dry, apply a finishing compound and let it dry. Finish the installation by sanding the surface smooth, priming it and painting it.



Figure 6 (Step 4B): Hanger Bracket Install Using Angles (other methods similar)

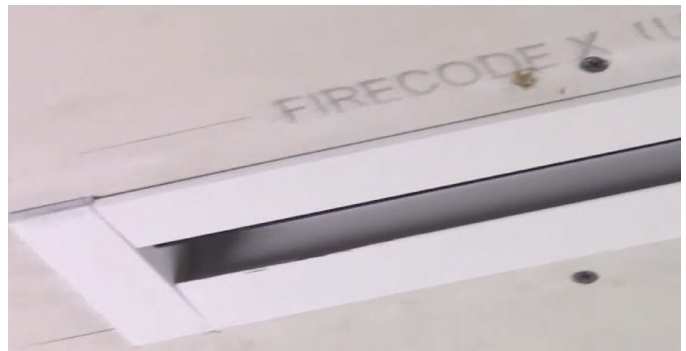

Figure 7 (Step 4C)



Installation Instructions for Concealed Spline Mount (-22-73 Frame)

This section applies to Greenheck model XG-6600-22-73 specifically.

Step 1 – Mounting Hardware

- A. Locate and ensure all proper mounting brackets and screws were supplied with the linear diffuser before starting installation. See Figure 8 for a table showing how many hanger brackets are shipped with the corresponding linear lengths.

XG-6600 Linear Length	Number of Hanger Brackets
24" or less	2
> 24" to 48"	3
> 48" to 60"	4
> 60" to 96"	6

Figure 8 (Step 1A)

Step 2 – Framing the Opening

- A. Before installing drywall, an adequate frame must be constructed for the Greenheck XG-6600 Linear Slot Diffuser. This framing must be suitable to hold the weight of the diffuser (typically wood framing). The length and width of the framing depends on the length and number of slots of the linear diffuser being installed.
- B. In general, the length of the opening within the framing should be the ordered size + 1-5/8" if the unit has end borders, and if the unit has end caps, the length of the opening should be the listed size + 1/4" (see Figure 9) and the opening width should be the "D1" dimension from the Greenheck XG-6600-22-73-74-75 submittal plus 1/2". For convenience, we have provided the dimensional drawing (see Figure 10) and dimension table (see Figure 11) from the XG-6600-22-73-74-75 submittal (please note the most up-to-date information will be on the submittal).

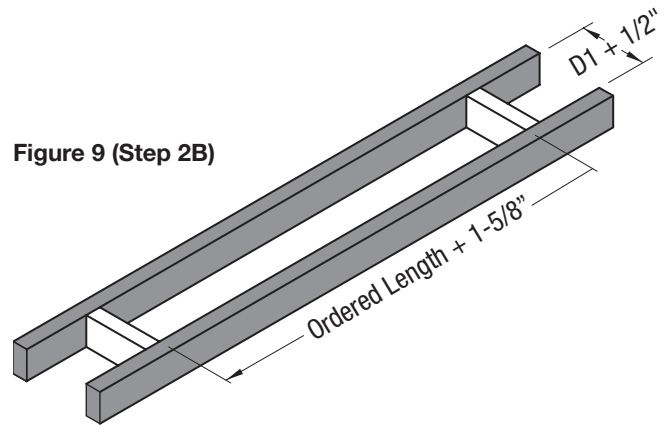

Figure 9 (Step 2B)

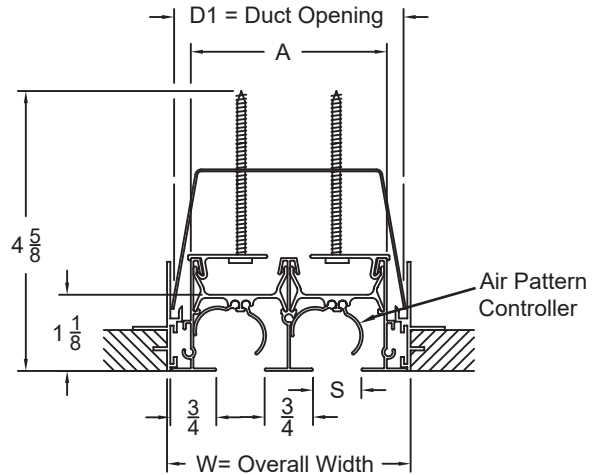

Figure 10 (Step 2B): XG-6600-22-73 Cut Section

# of Slots	D1 Dimension (Inches)			
	XG-6650 (1/2" Slot)	XG-6675 (3/4" Slot)	XG-6610 (1" Slot)	XG-6615 (1-1/2" Slot)
1	1-11/16"	1-15/16"	2-3/16"	2-11/16"
2	3"	3"	4"	5"
3	4-3/16"	4-15/16"	5-11/16"	7-3/16"
4	5-7/16"	6-7/16"	7-7/16"	9-7/16"
5	6-11/16"	7-15/16"	9-3/16"	-
6	8"	9"	11"	-
7	9-3/16"	10-15/16"	12-11/16"	-
8	10-7/16"	12-7/16"	14-7/16"	-

Figure 11 (Step 2B): XG-6600-22-73 Dimension Table

Step 3 – Installing Sub Frame

- A. The hanger bracket hardware is meant to be installed above the plane of the sheet rock in the sub frame provided. Once installed above that plane, using the screws provided, you will be able to screw from the face of the diffuser and the linear diffuser will be pulled up into the opening/sub frame.
- B. Install and secure sub frame provided in framing – see Figure 12. Note: sub end borders need to be cut to size and notched if used.

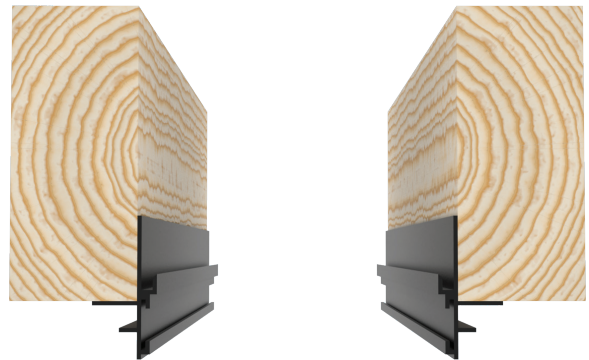

Figure 12 (Step 3B):
Sub Frame Installed in Framing

Step 4 – Installing Sheet Rock / Drywall

- A. Install drywall below framing, butted up against the lower section of the subframe – see Figure 13.

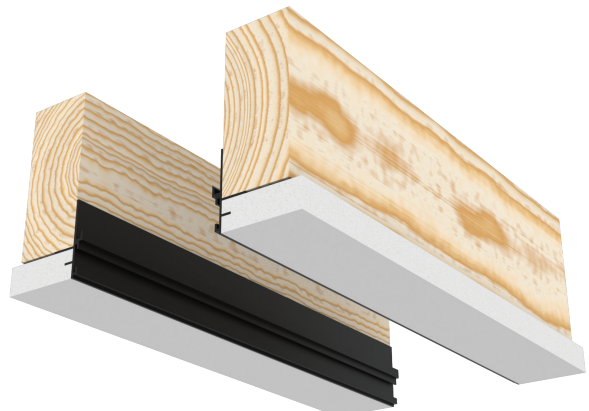

Figure 13 (Step 4A)

Step 5 – Installing Hanger Brackets

- A. To start, insert the screw through the face of the diffuser and start the screw into the hanger bracket – do not tighten all the way, only enough to be attached – see Figure 14.
- B. Push all brackets up into the opening until all hanger brackets get caught on the sub frame support – see Figure 15.
- C. Using a screwdriver or drill, tighten the screws to pull the linear slot diffuser up into the opening.

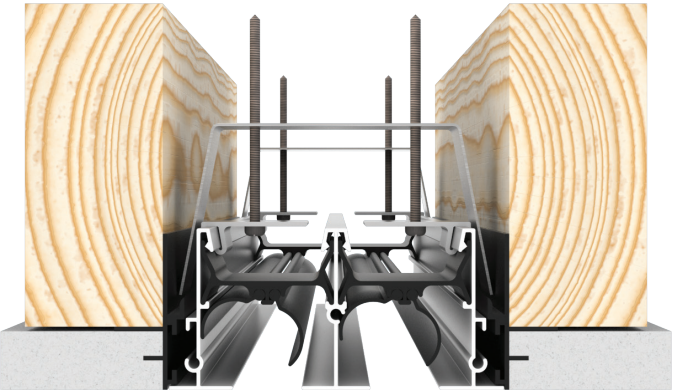
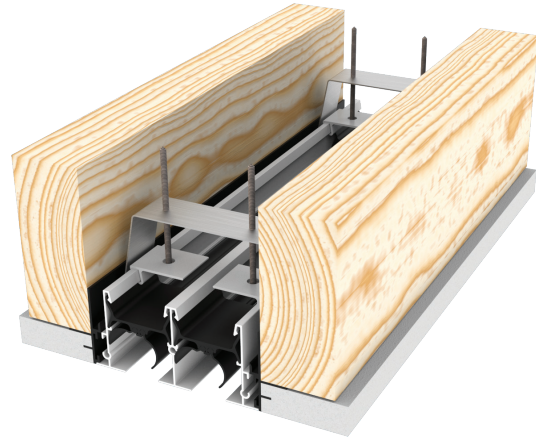

Figure 15 (Step 5B): Install Linear Into Sub Frame



Figure 14 (Step 4A)



Operation

Pattern Controller Adjustment (Supply Models Only)

The pattern controllers can be used to adjust the direction of the airflow as well as dampen the volume of airflow when needed.

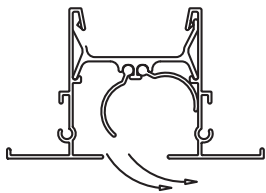

Horizontal Right

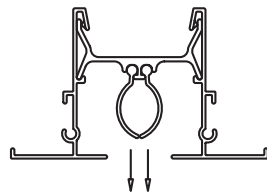

Vertical

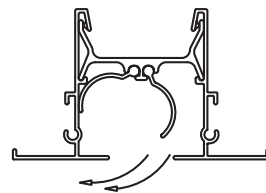

Horizontal Left

General Maintenance

Linear Slot Diffusers are basically maintenance free. The face of most diffusers can be cleaned with water and mild detergent if dirt and dust begin to build up.

Our Commitment

As a result of our commitment to continuous improvement, Greenheck reserves the right to change specifications without notice.

Product warranties can be found online at Greenheck.com, either on the specific product page or in the literature section of the website at Greenheck.com/Resources/Library/Literature.

