

Installation, Operation and Maintenance Manual

Please read and save these instructions for future reference. Read carefully before attempting to assemble, install, operate or maintain the product described. Protect yourself and others by observing all safety information. Failure to comply with these instructions will result in voiding of the product warranty and may result in personal injury and/or property damage.



Table of Contents

General - Safety Information	2
Receiving Inspection and Hanging/Installation Requirements	3
General - Model Number Code	3
Installation	4
Troubleshooting	7
Flow Sensor	9-10

General - Safety Information

Only qualified personnel should install this unit. Personnel should have a clear understanding of these instructions and should be aware of general safety precautions. Improper installation can result in electric shock, possible injury due to coming in contact with moving parts, as well as other potential hazards. If more information is needed, contact a licensed professional engineer before moving forward.

1. Follow all local electrical and safety codes, as well as the National Electrical Code (NEC), the National Fire Protection Association (NFPA), and the Canadian Electrical Code (CEC), where applicable.
2. Unit must be securely and adequately grounded.
3. Verify that the power source is compatible with the equipment.
4. Electrical equipment should be transported, stored, installed, and operated only in the environment for which it is designed.

DANGER

Improper installation, adjustment, alteration, service or maintenance can cause property damage, injury or death. Read the installation, operating and maintenance instructions thoroughly before installing or servicing this equipment.

WARNING

Always disconnect power before working on or near a unit. Use appropriate lockout tagout procedures to prevent accidental power up.

NOTICE: This appliance is not intended for use by persons (including children) with reduced physical, sensory or mental capabilities, or lack of experience and knowledge, unless they have been given supervision or instruction concerning use of the appliance by a person responsible for their safety. Children should be supervised to ensure that they do not play with the appliance.

Receiving Inspection and Hanging/Installation Requirements

Prior to removing the shipping materials, visually inspect the packing materials. There should be a black plastic strip wrapped in the clear plastic stretch wrap. If this black plastic strip is missing, the shipment may have been repacked by the shipper and you should make a note of this on the shipping documents and inform the delivering carrier. If any damage or other concerns are present, make a note of this on the shipping documents and inform the delivering carrier.

After unpacking the Single Duct Air Terminals, check for shipping damage. If any shipping damage is found, report it immediately to the delivering carrier.

Always store the product in a clean dry location prior to installation.

Units with controls are not recommended for use in ambient temperatures greater than 95°F. For protection of controls, do not store in temperatures above 135°F.

The unit maximum operating Inlet Air Temperature is 100°F.

The unit maximum operating static pressure is 3.0 in. wg.

General - Model Number Code

The model number code provides basic identification of the unit. Example: XG-TH06

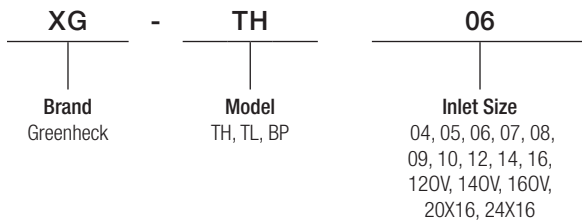

Installation

CAUTION: HAZARD OF EQUIPMENT DAMAGE

Do not use the flow sensor, connecting tubing or damper shaft as a lift point. Damage to the components may result.

NOTICE: Unit is not recommended for installation above 2,000 m.

NOTICE: The Single Duct Powered Air Terminal must be installed such that the bottom of the unit is at a height of 2.5 m or greater.

NOTICE: Zero clearance to combustable surfaces.

Unless local building codes require hangers, the smaller size basic Single Duct Air Terminals may be light enough to be supported by the ductwork itself. However, when accessory components such a controls, hot water reheat coils, sound attenuators or electric reheat are included, the single duct terminal should be supported directly with straps screwed into the side of the terminal. (See figure 1)

Figure 1 - Hanging Straps

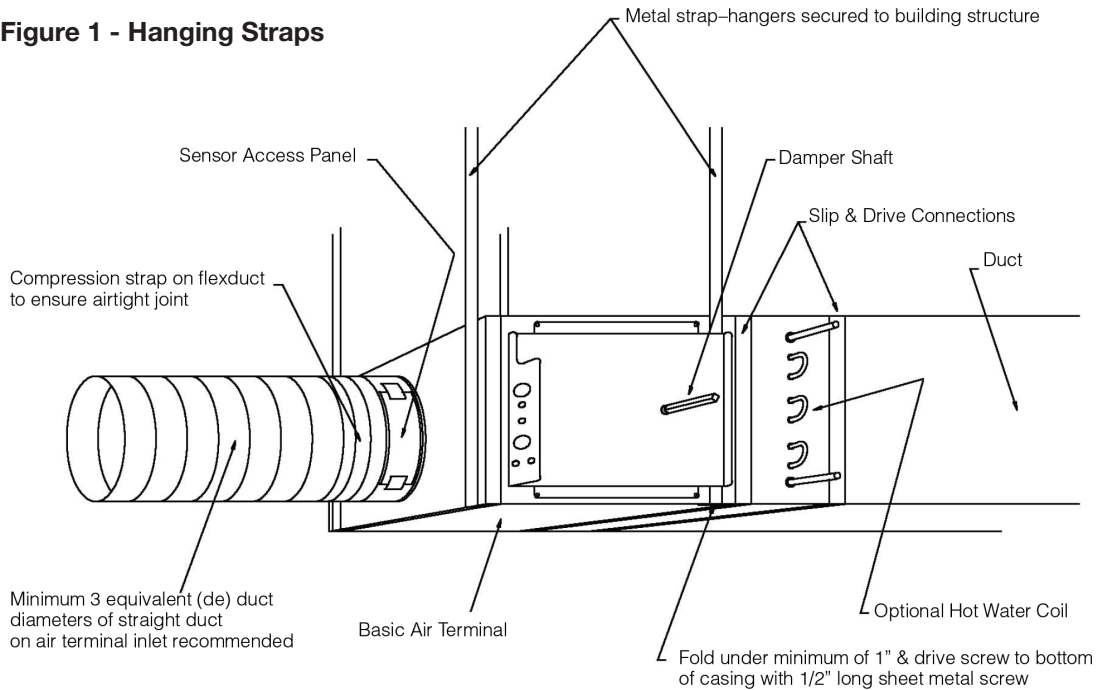

Alternate trapeze hangers or the method prescribed for the rectangular duct on the job specification may be used. (See figure 2)

Figure 2 - Trapeze

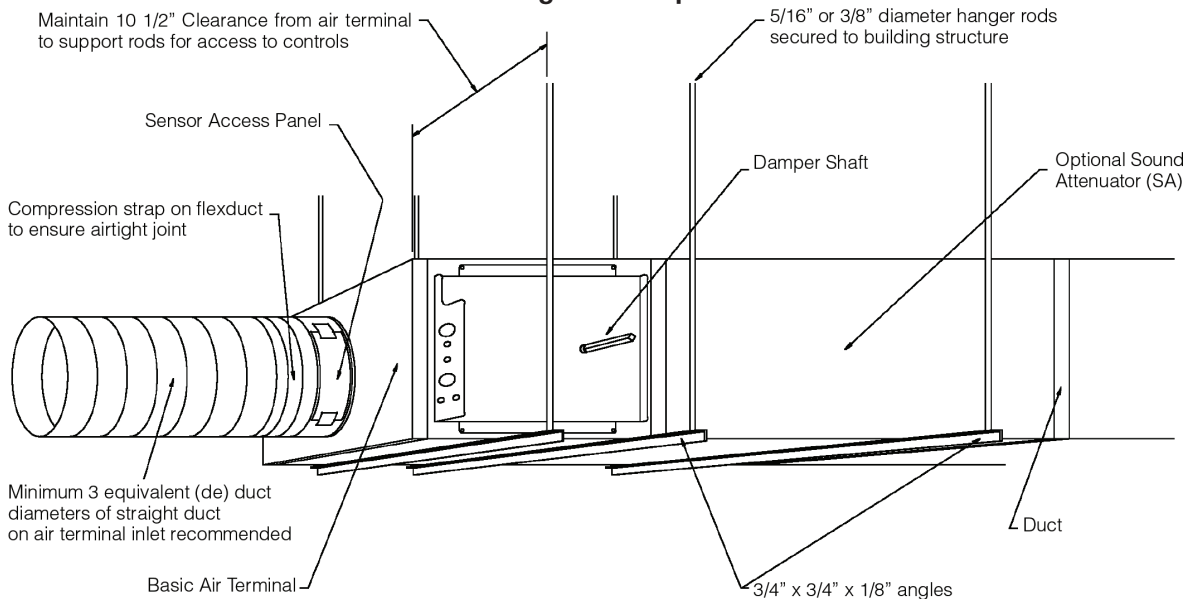

Single Duct Air Terminals may also be suspended with factory-supplied and field-installed hanger brackets and field-supplied and installed hanger rods. (See figure 3)

Figure 3 -Optional Hanger Brackets and Hanger Rods

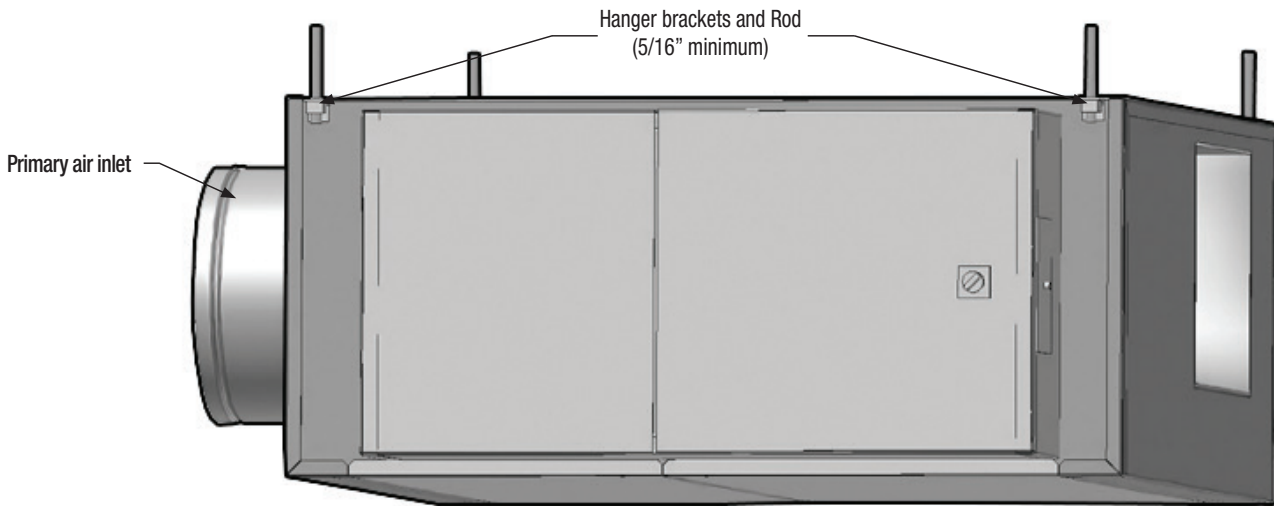

Single Duct Terminal Units are not designed nor suitable for outdoor use.

In advance of start-up, verify all electrical connections are tight and the correct voltage is supplied to the Single Duct Terminal Unit per the rated voltage listed on the unit label. If factory-supplied controls are present, review all wiring diagrams to assure a complete working knowledge.

IMPORTANT

If equipped with pneumatic controls, the orientation of the Single Duct Air Terminal unit is critical. The pneumatic controls must be mounted right side up. The Single Duct Terminal must be level within + or – 10 degrees of horizontal, both parallel to the airflow and at right angle of airflow. The control side of the Single Duct Terminal is labeled with an arrow indicating up. Unless otherwise noted, most electric, analog electronic and digital controls are not position sensitive and may be installed in any orientation.

MINIMUM CLEARANCE FOR ACCESS

Single Duct Air Terminals require sufficient space to allow servicing of the controls and electric reheat power hookup (if applicable). Horizontal clearance requirements are dependent upon access panel dimensions which are indicated on the appropriate submittal. For control panel access, a minimum of 18" is recommended. See the appropriate submittal for control panel location.

CAUTION

These clearance recommendations are not meant to preclude NEC requirements or local building codes that may be applicable, which are the responsibility of the installing contractor.

CONNECTING DUCT WORK

NOTICE: Do not insert duct work inside the inlet collar of the Single Duct Air Terminal. Inlet duct should be installed in accordance with SMACNA guidelines.

1. Slip each inlet duct over the inlet collar of the Single Duct Air Terminal.
2. Fasten and seal the connection by method prescribed by job specification.
3. The diameter of the inlet duct in inches must be equal to the listed size of the Single Duct Air Terminal; e.g., a duct that actually measures 8 inches must be fitted to a size 8-inch Single Duct Air Terminal. The inlet tube of the Single Duct Air Terminal is manufactured 1/8" smaller than the listed size in order to fit inside the duct.
4. If an inlet airflow sensor is installed, it is recommended the installer provide a minimum of 3 duct diameters of straight duct at the Single Duct Air Terminal inlet.
5. The outlet end of the Single Duct Air Terminal is designed for use with slip and drive duct connections (flanged outlets optional).
6. A rectangular duct the size of the Air Terminal outlet should be attached. (Refer to submittal for correct size.)

FIELD ELECTRICAL WIRING

DANGER

High voltage electrical supply is needed for this equipment. The control cabinet contains live electrical parts. Contacting these parts with power applied may cause serious injury or even death. This work should only be performed by a qualified electrician.

All field wiring must comply with local building codes and NEC. (ANSI/NFPA 70).

When applicable, electrical control and piping diagrams are attached to the inside of the control enclosure cover of the Single Duct Air Terminal.

Use copper only conductors with insulation rated 75°C.

The Single Duct Air Terminal must be properly grounded per NEC 424-14 and 250.

Always check product label for voltage and current data to determine the proper wire size and over current protection.

The control panel cover must be closed or in place before applying electric power to the Single Duct Air Terminal.

These recommendations are not meant to preclude NEC requirements or other applicable local building codes and are the sole responsibility of the installing contractor.

NOTICE: If the unit is not ordered with an internal disconnecting device then a disconnection device that shall disconnect all phases must be provided by the customer and incorporated in the fixed wiring.

SINGLE DUCT AIR TERMINALS WITH ELECTRICAL REHEAT

WARNING

Single Duct Air Terminals must not be operated without downstream ductwork in place. Failure to have downstream ductwork installed will expose the line voltages and high temperature present in the operating heater elements. Contact with these heater elements may cause serious injury or death.

- Prior to installation always inspect the electric heating coils for damage.
- All electric reheat is balanced by kW per stage.
- The installing electrician should rotate the electric reheat stages by phase in order to balance the buildings electrical load.
- The "UP" arrow orientation must be followed to prevent nuisance tripping or overheating which will cause damage to the electric heater and or building.

SINGLE DUCT AIR TERMINALS WITH HOT WATER COILS

CAUTION: HAZARD OF EQUIPMENT DAMAGE

The copper tubing should not be used as lift points. Always inspect the hot water coils for damage prior to installing the Single Duct Air Terminal.

- The hot water coil casing must be field insulated.
- The hot water coils do not have drip pans and are not suitable for use as cooling coils.
- The hot water coil maximum water operating temperature is 195°F.
- The hot water coils are leak tested to 300 psi, with a minimum burst pressure of 2000 psi at ambient temperature.
- The hot water coil maximum operating water pressure is 250 psi.

CONTROLS

NOTICE: Single Duct Air Terminals with digital controls, if factory programmed, incorporate specific communication addresses. Installing the Single Duct Air Terminal in a different location than noted on the Single Duct Air Terminal label and building plans may result in excessive start-up labor and is the sole responsibility of the contractor.

For information on controls provided by other manufacturers and installed on the Air Terminals, contact the local branch or dealer.

INLET FLOW SENSOR

Single Duct Air Terminals are shipped with factory-installed (where applicable) pressure differential inlet flow sensors in the primary inlet. See **figure 4** for calibration curve and K factors. Bypass Air Terminals offer an optional downstream flow sensor for field installation a minimum of 3 feet downstream of box discharge.

Troubleshooting

Investigating Noise Complaints

- Noise from a Single Duct Air Terminal can be due to a variety of conditions and can be difficult to eliminate.
- The first step is to isolate the type, source and direction.
- Generally, noise heard at the air outlet is considered a discharge type.
- Noise heard through the ceiling is considered radiated noise.
- For detailed information concerning noise transmission in buildings, refer to AHRI Standard 885-2008, "Procedure for estimating occupied space sound levels in the application of air terminals and air outlets."

Discharge Noise

- This is usually caused by high static pressure or little to no internal duct lining downstream of the Air Terminal.
- It can sometimes be caused by the air outlet itself.
- Air outlet generated sounds can be reduced by reducing flow or increasing an outlet size.
- Reducing static pressure, flow or adding additional downstream attenuation materials will reduce discharge sounds from the Air Terminal.

Radiated Noise

- Radiated noise is most commonly associated with Fan Powered Terminals.

Electric Duct Heater

CAUTION

Use extreme care if testing the electric heater with power on.

The control cabinet contains live electrical parts. Contacting these parts with the power applied may cause serious injury or death.

This unit should be serviced by a licensed electrician or a similarly qualified electrical service technician.

If the electric heater does not operate:

- Check electric power into the unit and verify the input power agrees with the label data.
- Verify the Air Terminal is installed properly (according to the airflow orientation).
- Review the wiring diagram attached to the inside of the control enclosure cover to verify the field wiring is correct with proper gauge wire, overcurrent protection and properly grounded.

If the electric heater cycles on and off:

- Verify the airflow is uniformly distributed across the face of the heater elements.
- Check for obstructions in the duct or insufficient airflow. (70 cfm per kW required)

If conditioned space fails to warm up:

- Verify the electric heater controls and thermostat are compatible and wired properly.
- Relocate the room thermostat if it is located in a position that is too warm.

If condition space overheats:

- Verify the electric heater controls and room thermostat are compatible and wired properly.
- Relocate the room thermostat if it is located in a position that is too cold.
- Verify the air distribution to the space is appropriate for the required thermal load.

Specific Electric Heater Troubleshooting Procedures:

PROBLEM: Heater Does Not Energize	
Cause	Solution
Power not properly connected to the heater	<ol style="list-style-type: none"> 1. With a voltmeter, check the power wiring terminals to ensure proper voltage is available to the heater element side of the power terminal block or to the field side of the disconnect switch, power fusing or circuit breaker. 2. If proper voltage is not present, check the terminal studs for proper wiring and check power source for power.
Disconnect switch, toggle switch or circuit breaker are set to OFF position	<ol style="list-style-type: none"> 1. Set disconnect switch, toggle switch or circuit breaker to ON position.
Power fuses are blown or circuit breaker is tripped	<ol style="list-style-type: none"> 1. Replace fuse(s) with same type and amperage as those provided with the heater from the manufacturer or reset circuit breaker by first setting circuit breaker to OFF position then resetting to ON position. 2. With an ammeter, check amp draw on the power lines. 3. For heaters with fusing, amp draw should not exceed the fuse amperage. 4. Amp draw should not exceed the circuit breaker rated value. 5. If the amp draw is excessive, check the power supply as described above for power voltage. 6. If fuses blow or circuit breaker trips again, check for a short. 7. If no short is present and the power supply wiring/voltage are correct, contact factory for further assistance.
Manual reset safety switch has tripped	<ol style="list-style-type: none"> 1. Push the reset safety button on back of safety reset. The manual safety reset is located inside the control enclosure cover near the bottom on the heater element header.
Airflow/static switch is not engaging	<ol style="list-style-type: none"> 1. Jumper out the airflow/static switch by connecting the lead attached to the normally open terminal to the normally closed terminal. 2. If the heater starts operating, two conditions could exist. <ol style="list-style-type: none"> A. The airflow/static switch may be defective. B. There is insufficient airflow to make the switch. 3. To verify available static pressure, disconnect the pneumatic tubing from the HI side of the airflow/static switch and connect to a magnehelic gauge. 4. The differential pressure should be at least 0.08 in. wg. 5. It is recommended that at least 0.2 in. of downstream static pressure is available. 6. If available static pressure is in a dead band, between the two ranges, the airflow/static switch will not engage and could cause chattering of the contacts. Some method must be devised to increase the available static pressure. 7. If sufficient static pressure is available, check to ensure the pneumatic tubing is connected to the correct port (HI) on the airflow/static switch.

Specific Electric Heater Troubleshooting Procedures:

PROBLEM: Heater Does Not Energize	
Cause	Solution
Automatic Safety Reset Switch is bad	<ol style="list-style-type: none"> 1. Allow the duct temperature to cool down below 90°F. 2. If the heater still does not energize, jumper out the automatic safety reset switch. 3. If the heater now energizes, contact the factory for a replacement automatic safety reset switch.
Manual Safety Reset Switch is bad	<ol style="list-style-type: none"> 1. Allow the duct temperature to cool down below 90°F. 2. If the heater still does not energize, perform the following: <ol style="list-style-type: none"> A. On heaters with the manual safety reset switch connected in the backup contact circuit, jumper out the manual safety reset switch. B. If the backup contactor now engages, contact the factory for a replacement manual safety reset switch. C. If the backup contactor fails to engage, there is a problem in the backup contactor holding coil. D. Use an ohmmeter to check continuity of the holding coil on the backup contactor. E. If bad, contact factory for replacement backup contactor.
Insufficient airflow across the electric heating elements	<ol style="list-style-type: none"> 1. The minimum allowable airflow across the heating elements is 70 cfm/kW. 2. Unless this recommended minimum airflow is met, the leaving air temperature of the heater will be greater than the safety reset switch limits. This will cause nuisance tripping of the safety reset switch. 3. Reset the minimum airflow across the heating elements during a call for heat at 70 cfm/kW.

WARNING

On all troubleshooting that requires working inside the heater casing, disconnect the power first! Jumpers used for diagnostic purposes should be removed before returning the heater to normal operation.

Figure 4 - Multi-Quadrant Averaging Flow Sensor

MODEL	INLET SIZE	K FACTOR
XG-TH, XG-FCI, XG-FCQ XG-FVI, XG-DD XG-DH, XG-BP XG-RT, XG-RA XG-TL (4 to 10) XG-FCI C2 (4 to 8) XG-FVL C2 (4 to 8)	04 Rnd	300
	05 Rnd	375
	06 Rnd	540
	07 Rnd	760
	08 Rnd	990
	09 Rnd	1250
	10 Rnd	1640
	12 Rnd	2350
	14 Rnd	3250
	16 Rnd	4100
XG-TL (12)	12 Flat Oval	2270
XG-TL (14) & XG-FVL C6	14 Flat Oval	2850
XG-TL (16)	16 Flat Oval	3550
XG-FVL C4	14x8 Rect	2450
XG-FCI C4	16x8 Rect	2770
XG-FCI, XG-FCQ, & XG-FVI C7	18x16 Rect	6200
XG-TH 20	20x16 Rect	6430
XG-TH 24	24x16 Rect	7270

Note: K-factor is the calibration flow constant at 1 in. wg delta P



How to tell which sensor you have:
Multi-quadrant - two additional metal balancing taps directly out of the inlet tube.

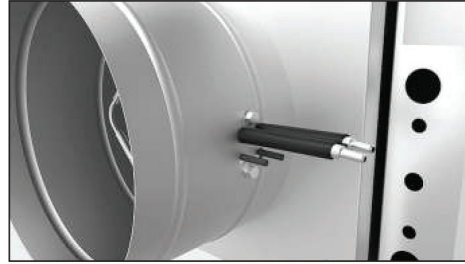

$$Cfm = \sqrt{\Delta p} \times K \text{ Factor}$$

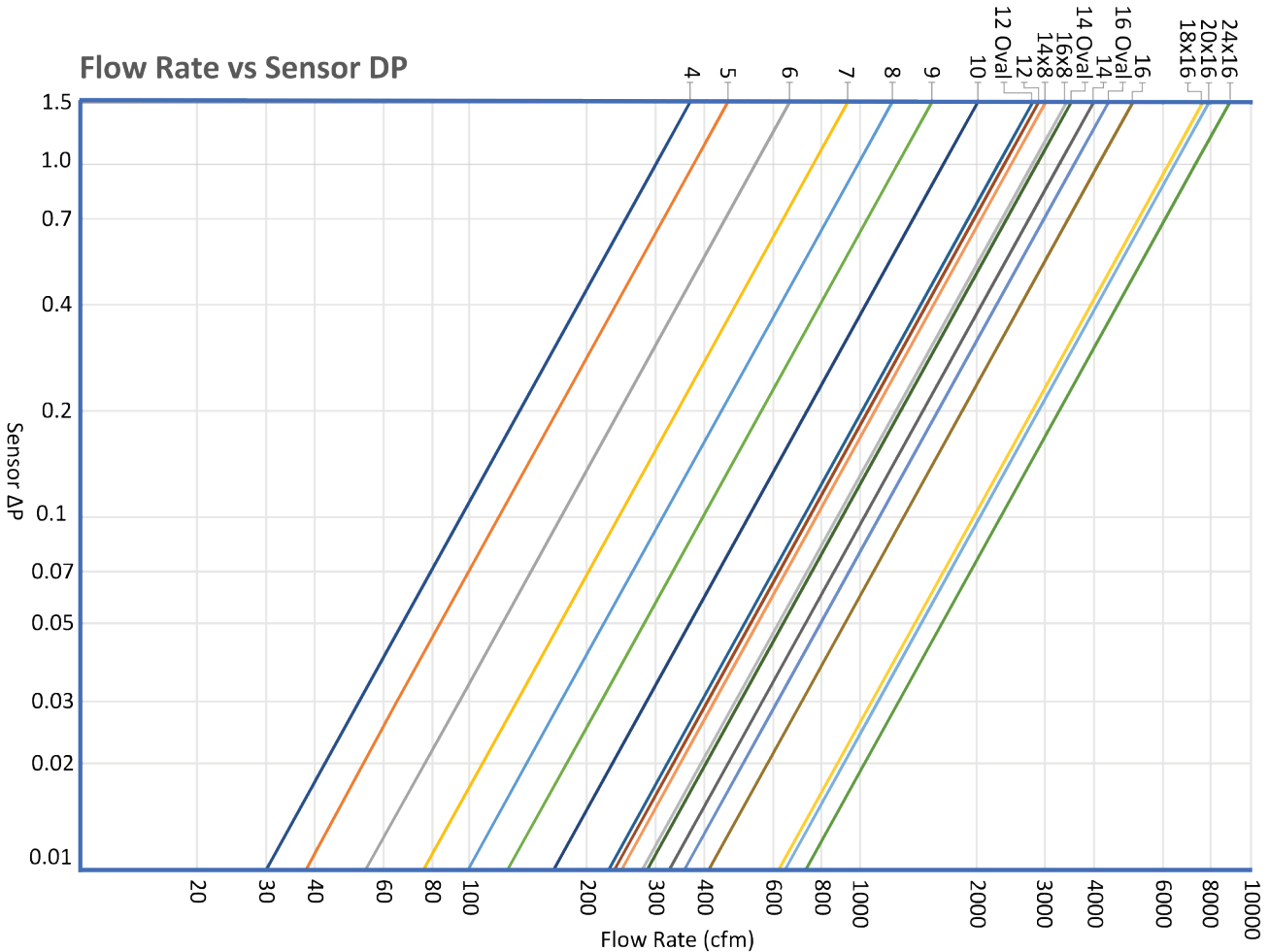

Center Averaging Flow Sensor

INLET SIZE	K FACTOR
4	215
5	345
6	517
7	658
8	929
9	1154
10	1417
12	2082
14	2718
16	3698
120V	2010
140V	2610
160V	3712
14x8	2491
16x8	2816
18x16	5297
20x16	5670
24x16	6797

Note: K-factor is the calibration flow constant at 1 in. wg delta P



How to tell which sensor you have:

Center Averaging - only two tubes coming out of the inlet tube with a T in the middle of the tubing.

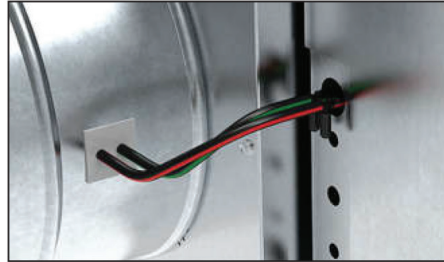

$$Cfm = \sqrt{\Delta p} \times K \text{ Factor}$$

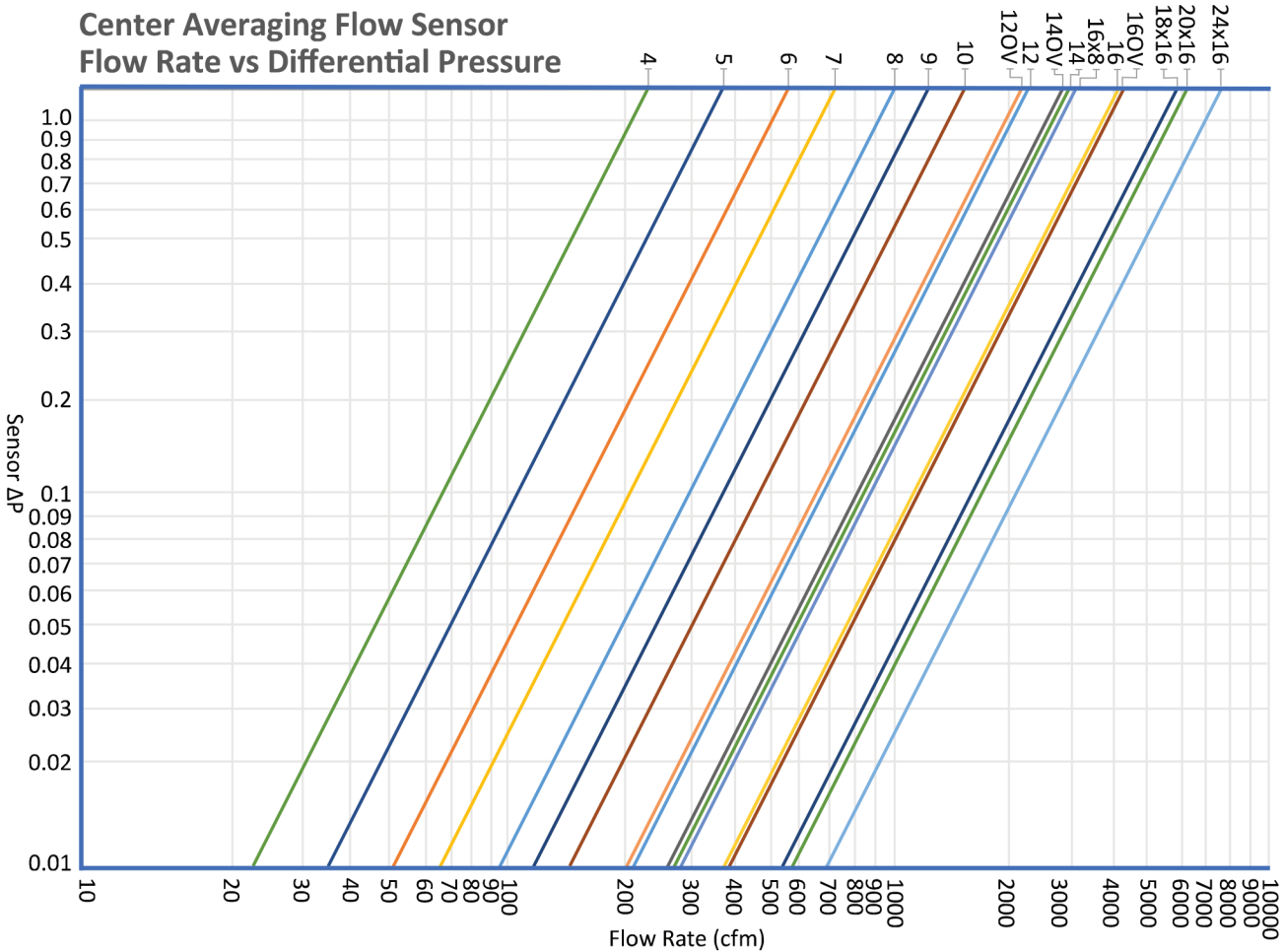

Our Commitment

As a result of our commitment to continuous improvement, Greenheck reserves the right to change specifications without notice.

Product warranties can be found online at Greenheck.com, either on the specific product page or in the literature section of the website at Greenheck.com/Resources/Library/Literature.

