

## Installation, Operation and Maintenance Manual

Please read and save these instructions for future reference. Read carefully before attempting to assemble, install, operate or maintain the product described. Protect yourself and others by observing all safety information. Failure to comply with these instructions will result in voiding of the product warranty and may result in personal injury and/or property damage.



### Table of Contents

General Safety Information . . . . .	2
Introduction to the Microprocessor Control and High Voltage Panel. . . . .	3
MOA Control and Power System Components . . . . .	4
Wire Installation and Routing . . . . .	5-9
General Operation . . . . .	10-11
Control Panel Field Wired Inputs and Outputs . . . . .	12
Microprocessor Display Use. . . . .	13
Parameter Adjustment . . . . .	14
Controller Navigation. . . . .	15
Main Screen . . . . .	16
Menu . . . . .	17-22
Touch Screen Display Use. . . . .	23
Home Screen. . . . .	24
Menu . . . . .	25-26
Fan Status . . . . .	27
Troubleshooting . . . . .	28
Appendix A: Power and Control Box Interconnect Drawing . . . . .	29
Appendix B: Control Panel Wire Diagram . . . . .	30-31
Appendix C: Points List . . . . .	32-51
Maintenance Log. . . . .	Backcover

#### DANGER

Always disconnect, lock and tag power source before installing or servicing. Failure to disconnect power source can result in fire, shock or serious injury.

#### CAUTION

When servicing the fan, motor may be hot enough to cause pain or injury. Allow motor to cool before servicing.

#### CAUTION

Precaution should be taken in explosive atmospheres.

#### DANGER

Pour écarter les risques d'incendie, de choc électrique ou de blessure grave, veiller à toujours débrancher, verrouiller et étiqueter la source de courant avant l'installation ou l'entretien.

#### ATTENTION

Lors de toute intervention sur la soufflante, le moteur peut être suffisamment chaud pour provoquer une douleur voire une blessure. Laisser le moteur refroidir avant toute maintenance.

#### ATTENTION

Faire preuve de précaution dans les atmosphères explosives.

## General Safety Information

---

Only qualified personnel should install this unit. Personnel should have a clear understanding of these instructions and should be aware of general safety precautions. Improper installation can result in electric shock, possible injury due to contact with moving parts, as well as other potential hazards. If more information is needed, contact a licensed professional engineer before moving forward.

1. Follow all local codes, as well as the National Electrical Code (NEC), the National Fire Protection Agency (NFPA), where applicable. Follow the Canadian Electrical Code (CEC) in Canada.
2. Do not allow power cable to kink or come in contact with oil, grease, hot surfaces, or chemicals. Replace cord immediately if damaged.
3. Verify the power source is compatible with the equipment.

### Receiving

Upon receiving the product, check to ensure all items are accounted for by referencing the delivery receipt or packing list. Inspect each crate or carton for shipping damage before accepting delivery. Alert the carrier of any damage detected. The customer will make a notation of damage (or shortage of items) on the delivery receipt and all copies of the bill of lading which is countersigned by the delivering carrier. If damaged, immediately contact your local sales representative. Any physical damage to the unit after acceptance is not the responsibility of the manufacturer.

### Unpacking

Verify that all required parts and the correct quantity of each item have been received. If any items are missing, report shortages to your local representative to arrange for obtaining missing parts. Sometimes it is not possible that all items for the unit be shipped together due to availability of transportation and truck space. Confirmation of shipment(s) must be limited to only items on the bill of lading.

### Handling

Handle in such a manner as to keep from scratching or damaging components. Damage to components may reduce ability of system to resist corrosion.

### Storage

Units are protected against damage during shipment. If the unit cannot be installed and operated immediately, precautions need to be taken to prevent deterioration of the unit during storage. The user assumes responsibility of the unit and accessories while in storage. The manufacturer will not be responsible for damage during storage. These suggestions are provided solely as a convenience to the user.

#### Indoor

The ideal environment for the storage of units and accessories is indoors, above grade, in a low humidity atmosphere which is sealed to prevent the entry of blowing dust, rain, or snow. Temperatures should be evenly maintained between 30°F (-1°C) and 110°F (43°C). Wide temperature swings may cause condensation and “sweating” of metal parts. All accessories must be stored indoors in a clean, dry atmosphere. Remove any accumulations of dirt, water, ice, or snow and wipe dry before moving to indoor storage. To avoid “sweating” of metal parts, allow cold parts to reach room temperature. To dry parts and packages, use a portable electric heater to eliminate any moisture build up. Leave coverings loose to permit air circulation and to allow for periodic inspection. The unit should be stored at least 3-1/2 in. (89 mm) off the floor on wooden blocks covered with moisture proof paper or polyethylene sheathing. Aisles between parts and along all walls should be provided to permit air circulation and space for inspection.

### Inspection and Maintenance during Storage

While in storage, inspect equipment once per month. Keep a record of inspection and maintenance performed. If moisture or dirt accumulations are found on parts, the source should be located and eliminated.

### Removed from Storage

As units are removed from storage to be installed in their final location, they should be protected and maintained in a similar fashion, until the equipment goes into operation. Prior to installing the unit and system components, inspect the unit assembly to make sure it is in working order. Check all fasteners and accessories for tightness.

# Introduction to the Microprocessor Control and High Voltage Panel

## Electrical Panel

The high voltage electrical panels and wiring are provided with the unit to simplify the electrical installation.

## Control Panel

A control panel is provided with the unit that contains a preprogrammed microprocessor and mounted pressure transducer.

## Program Features

The microprocessor controller offers control through easy monitoring and adjustment of unit parameters by way of a lighted graphical display and an integral push-button keypad.

## Preprogrammed Operating Sequences

The controller has been preprogrammed to offer control of the array using the provided pressure transducer. Pressure monitoring is local to the array. The controller may be controlled by an external 0-10V from a source such as a BMS.

## Building Management System (BMS) Communication

The user can remotely adjust set points, view unit status points and alarms. The microprocessor controller is capable of communicating over several protocols:

- BACnet® MSTP
- Modbus RTU
- BACnet® IP
- Modbus TCP

Reference Points List for a complete list of BMS points.

## Alarm Management

The microprocessor controller will monitor the unit's status for alarm conditions. Upon detecting an alarm, the controller will record the alarm description, time, date, and input/output status points for user review. Alarms are also communicated via BMS (if equipped).

## Touch Screen Display (optional)

The 7-inch Touch Screen Display is an LCD screen that is mounted to the cover of the control panel. It is used to gain access to the unit controller allowing monitoring of the unit and parameter adjustment without opening the control panel.

### WARNING

Electrical shock hazard. May cause personal injury or equipment damage. Service must be performed only by personnel that are knowledgeable in the operation of the equipment being controlled.

Mechanical high static protection cutoffs must be installed by others to protect the system and equipment from over-pressurization when using factory provided control sensors. The manufacturer does not assume responsibility for this.

## MOA Control and Power System Components

All components for the Modular Open Array (MOA) are shipped loose and must be accounted for prior to installation. Refer to the submittal for exact quantities of components. Contact your local sales representative if discrepancies are found.

Shipped Loose Components	
Quantity	Description
1	Control panel
See submittal	Industrial Power Panel(s)
See submittal	Motor Power Cable Assemblies – See submittal for lengths*
1	RJ45 Communication Cables – 10 ft
See submittal	Differential pressure tubing
1	DC power patch cord – 6 ft

\*Manufacturer supplied wire and cabling is only viable for installations in which the Industrial Power Panel(s) and Control Panel are within ten linear feet from the MOA.

### Customer-Supplied System Components

- Mounting hardware for all components for all power and control panels.
- Power wiring from source to factory supplied power panel(s), including feeder protection and local disconnect.
  - Consult job submittal for quantity provided.
- Communications and/or control wiring from source to factory supplied control panel.
- Control wiring from BMS to factory supplied control panel. See Appendix A: Power and Control Box Interconnect drawing for details. *(Optional)*
- Control wiring from control panel to motors. *(Optional)*

# Wire Installation and Routing

The provided high voltage panel(s) and control panel shall be mounted per site requirements in accordance with the appropriate national standards and local codes. Power cable (TC-ER) and CAT5 cable are provided for each fan in the array, the length of which allows for the panel to be mounted within 10 linear feet from the side of the array wall. CAT5 cables and power pigtails are factory wired to each motor. A single 10 ft CAT5 cable is provided to connect the first motor in the array to the control panel.

If the panel must be mounted farther from the array, all extra wire will be supplied by the customer.

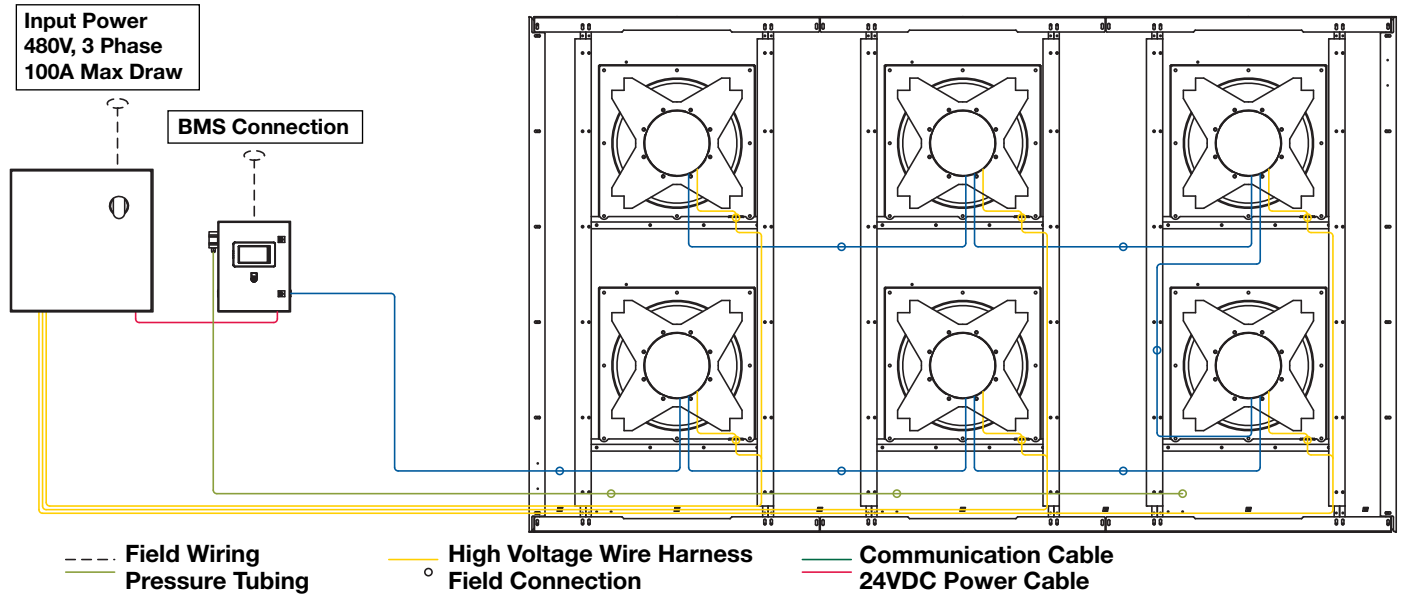

The provided field wires have a plug that will be mounted to a support on the array wall and connected to a mating component prewired to the motor. The last motor connected via the control cables will have an extra wire not needed for the array. This cable can be spooled and attached to the fan, or removed.



### Mounting to the array wall

The plug on the end of the motor power cable assembly will be mounted to a support on the right side of the fan/motor assembly support. The plug will engage with the support using two fastening legs on the clip.



### Connecting the motor

The mating plug from the motor can be secured to the previously mounted power cable assembly. The plug connection with the motor is not intended to be a disconnect.



### Routing the wires

Power wires shall be routed along the right-hand side of the fan panel and secured to the panel using the provided zip ties with pine tree fasteners, inserted into factory-cut holes.

Cable routing should be completed prior to installation of the sheet metal reinforcement angles, ensuring all cables are covered. For panels with multiple fans, the power cables can be bundled into the same zip tie.

Route and mount cables along the bottom L brackets of the MOA structure utilizing provided zip ties and holes in sheet metal pieces. Power cables should be routed away from communication wires to limit communication noise.

After the cable assemblies leave the footprint of the MOA, they shall be routed and mounted according to national standards and local codes.

### Connection at Panel

Land flying leads of motor power cables to appropriate branch circuit fuses within industrial power panel by certified personnel. All fuse holders in the Electrical Panel come with 15A fuses, factory installed.

Motor grounding is done through the motor power cable assembly to power box. A separate frame ground connection has not been designed into the array frame. Contact your local sales representative if protection against electrical noise is a concern.

### NOTE

Some fuse holders may remain unused after all motors have been wired.

## Communication Cable Installation and routing of communication cable

The control panel comes with quick connects for 24VDC power, communication to motors and to BMS.

All communication wires should be routed and secured to the left side of the fan, when possible. Communication and high voltage wires should be routed away from each other as much as possible to limit communication noise.



---

### Control Panel Power

---

A quick connect cable is provided with the control panel to power the control panel via the factory mounted quick connects on the industrial and control panels. See Appendix A: Power and Control Interconnect drawing for details.

Control box grounding is done through the DC power patch cord.



---

### Motor Communication

---

The RJ45 connector mounted to the control panel labeled "MOTOR" will be used to connect the controller to the first motor. (See Appendix A: Power and Control Box Interconnect drawing for port pin out.)

Each motor will have to be connected to the previous motor utilizing the factory mounted RJ45 cables on the motors with provided coupler. The two communication cables installed on the motor are connected internally, therefore the cables can be connected in any order. The last motor in the series will have a communication cable that is unused.

Communication cables shall be routed and mounted to the left side of the fan panel and secured to the array wall using provided zip ties.

Any extra length of communication cable can be coiled and secured to the fan assembly.



---

### BMS Communication

---

The control panel has two factory installed RJ45 ports for BMS communication, ethernet and RS485. It is possible for qualified personnel to mount the BMS communication directly to the controller via terminal J26 BMS2. (See Field Inputs for more information.)



## Pressure Differential Tubing Installation and routing of pressure differential tubing

Pressure differential tubing is pre-mounted to the fan panels and terminated at a bracket located at the lower left corner of the fan panel(s). All panels will be connected to the same main line that connects to the pressure transducer mounted on the control panel.

Black line represents the high-pressure value.

White line represents the low-pressure value.



### Panel connections

Using provided tubing and connectors, all fan panels shall be connected into a single line routed along the base of the MOA.

Tubing lines can be secured to the MOA using zip ties or other methods.

Do not pinch the tubing when tightening the zip ties.



### Connection to pressure transducer

Using the provided clear tubing and adapters located inside the control panel, connect the black tube to the Positive (+) connection on the pressure transducer and the white tube to the Negative (-) connection on the pressure transducer.

Tubing provided for the unit is 1/4-inch OD nylon tubing. The connector on the pressure transducer requires 6 mm ID tubing. Adapters are provided with the control panel to connect the black and white tube with the pressure transducer. It may be necessary to use a small section of clear tubing to complete the connection.



**Motor Addresses** Identification of motor address for communication to the controller

Motors will come with a preprogrammed IP address, 1-64, that match the number of fans that will be on the MOA. Fans will be labeled with the IP address for field identification. There is no need to install the motors in sequential order on the MOA wall, the address is only for communication purposes.

If there is a need to reprogram the IP address of a motor(s), contact the factory.



# General Operation

## Unit Disabled Command

The unit will become disabled due to the following:

- Unit is disabled from the controller's Unit Enable screen.
- Unit is disabled from the HOA (Hand/Off/Auto) switch.
- The remote start input does not have a signal.
- A system shutdown alarm is activated.

## Unit Start Command

The microprocessor controller requires a digital input to enable operation. The unit can then be commanded on or off by digital input or keypad. When a start command becomes active, the controller will ramp the fans up until the input setting, typically static pressure, is achieved. The controller will maintain this setting until a STOP command is received.

### NOTE

The fan motor always starts with at least 6% and stops below 4.5% of the rated speed with a minimum speed setting of 0 rpm. See diagram below for further details.

The motor always starts with at least 6% of the rated speed and stops below 4.5% of the rated speed (providing that the "Min. Speed" setting is "0" rpm see add-on-modules).

With the settings "E1 min." and "E1 max." (see add-on-modules) it is possible to adapt the setting signal/speed characteristic, e.g. for setting signal: 0...5V, 2...10V.

Diagram setting signal and motor speed

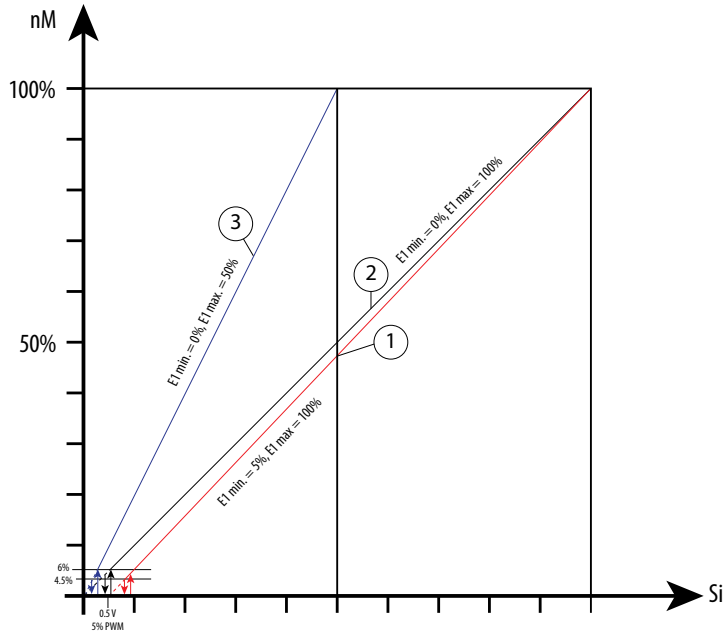

0	1	2	3	4	5	6	7	8	9	10	0 – 10 V
0	10	20	30	40	50	60	70	80	90	100	0 – 100% PWM

<b>nM</b>	<b>Motor speed</b>	<b>4.5%</b>	<b>Height of stop speed</b>
<b>100%</b>	<b>Rated speed</b>	<b>0.5 V / 5% PWM</b>	<b>Value start analog input (factory setting)</b>
<b>6%</b>	<b>Height of start speed</b>	<b>Si</b>	<b>Speed setting signal 0...10V / 0...100% PWM</b>

①	<p><b>Factory setting:</b> E1 min. = 5%, E1 max. = 100%</p> <p>0.5...10 V 0...100% speed setting</p> <p>i.e. the motor starts with 6% of the rated speed at a setting signal of approximately 1V.</p>
②	<p><b>Example:</b> E1 min. = 0%, E1 max. = 100%</p> <p>0...10 V 0...100% speed setting</p>
③	<p><b>Example:</b> E1 min. = 0%, E1 max. = 50%</p> <p>0...5 V 0...100% speed setting</p>

## **Unit Stop Command**

A shutdown occurs when the user of the BMS disables the system by using the HOA switch, keypad, or start signal is deactivated. Shutdown will also occur when the safety signal is interrupted. Once the shutdown is commanded, the fan(s) will lose the speed command and come to a stop.

## **Unit Status Output**

The microprocessor will send status outputs via digital signal, if activated by the user. The status will provide information if the unit is in alarm or is ready to receive a signal.

## Control Panel Field Wired Inputs and Outputs

The control panel for the MOA has field connections that can be utilized by the BMS to control and get feedback from the array. All field wiring is to be landed at the terminal strips located inside the control panel. Inputs must be activated in the *Unit Config* menu in the microprocessor. See Unit Config menu for more information.

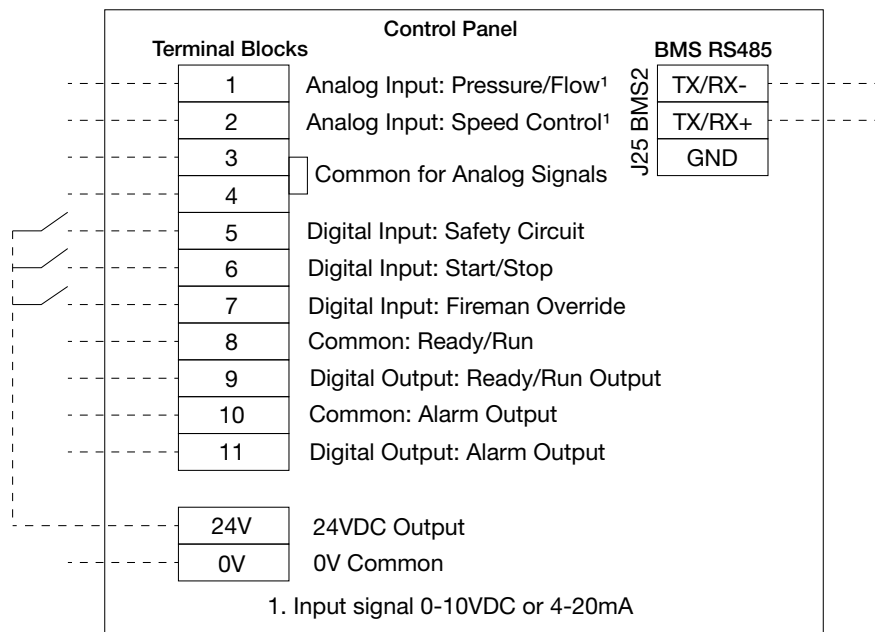

All inputs use a 24VDC signal unless noted above.

BMS communication can be connected via mounted RJ45 connection or hard wired into terminal J25 BMS2.

Digital inputs, terminals 5-7, are opto-isolated 24VDC dry contacts.

Digital outputs, terminals 8-11, are normally open relays.

### Speed Control Input

The microprocessor will come equipped with the optional use of a remote sensor 0-10V or 4-20mA signal and can be used to control the speed of the fans in the array. Input signal to be landed at Terminal 2 with reference landed at Terminal 3 or 4.

A read only input for remote pressure sensor can be landed on Terminal 1, with reference landed at Terminal 3 or 4, to allow for a read out to be available locally at the control panel.

### Digital Inputs

The microprocessor will come equipped to handle hard wired inputs from the BMS to control the array.

**Safety Circuit** – When enabled, the Safety Circuit is a normally closed circuit, the system will continue to run if a 24VDC signal is active on the input. If that signal is lost, a hard shut down will occur and the fans will cease running until the circuit is closed. Signal landed at Terminal 5 and reference landed at 0V (Common).

**Start/Stop Circuit** – When enabled, the Start/Stop Circuit will command the controller to start or stop the system in Auto mode. The Start command is active when a 24VDC signal is present. The Stop command will activate when no signal is present. Signal landed at Terminal 6 and reference landed at 0V (Common).

**Fireman Override** – When enabled, the Fireman Override will override all other speed commands from the BMS or controller and set the fans to ramp to the speed set in the *Unit Config* menu. Sending a 24VDC signal to the input will activate the input. Signal landed at Terminal 7 and reference landed at 0V (Common).

**Ready/Run Output** – When enabled, the Ready/Run Output will send a state change to the BMS for the array. When the system is commanded to start and no alarms are present, the controller will send a 24VDC signal to the BMS indicating that the system will accept a speed signal. Signal landed at Terminal 9 and reference landed at Terminal 8.

**Alarm Output** – When enabled, the Alarm Output will send an alarm signal to the BMS for the array. When the system is commanded to start and alarms are present, the controller will send a 24VDC signal to the BMS indicating that the system is in alarm. This signal will only indicate that an alarm is present in the system, further investigation may be necessary. Signal landed at Terminal 11 and reference landed at Terminal 10.

## Microprocessor Display Use

The microprocessor controller is located in the unit control panel. The face of the controller has six buttons, allowing the user to view the unit conditions and alter parameters. The microprocessor controller is preprogrammed with easy-to-use menus. A touch screen display mounted to the door of the control panel is also available. Controller comes with preinstalled BACnet® license.

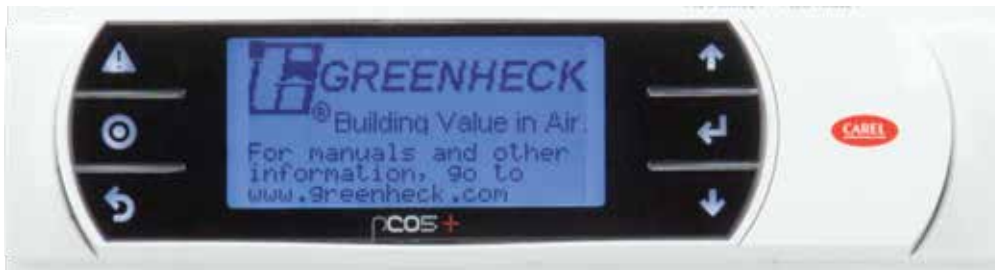

### Keypad Description



Button	Description	Functions
	Main Menu	Press to go directly to the Main Menu from any screen. A password screen will appear the first time the button is pressed or if the session has timed out. Default password: <b>1945</b> From the Main Menu, navigate to the following screens: Input/output BMS settings Device status Device config Unit config Alarm logs Settings Logout
	Alarm	The Alarm button flashes when there is an active alarm. Press to view alarms. Press twice to go to the alarms reset screen.
	Escape	Press from the Main Menu to view the Unit Status screen. Press to go back one menu level.
	Up	Press to navigate through the menus/screens. Press after entering a variable to increase a current value.
	Enter	Press to enter a highlighted menu or screen item. Press to enter a writable variable and press again to confirm the new variable value.
	Down	Press to navigate through the menus/screens. Press after entering a variable to decrease the current value.

## Parameter Adjustment

Unit Setup 1/8	
Process Control:	Pressure
Cntrl/ Auto/Man:	Auto
Man Setpoint:	ORPM
Remote Control:	Off
Rem. Cntrl Type:	UI2

The cursor always begins in the upper left corner of the display and will be blinking. Press the  button to move the cursor down for parameter adjustment.

Unit Setup 1/8	
Process Control:	Pressure
Cntrl/ Auto/Man:	Auto
Man Setpoint:	ORPM
Remote Control:	Off
Rem. Cntrl Type:	UI2

Once the cursor has reached the desired parameter, press the   buttons to adjust the value.

Unit Setup 1/8	
Process Control:	Pressure
Cntrl/ Auto/Man:	Auto
Man Setpoint:	ORPM
Remote Control:	Off
Rem. Cntrl Type:	UI2

When satisfied with the adjustment, press the  button to save the parameter. When finished, make certain the cursor is in the upper left corner. If the cursor is not in the upper left corner, the changes will not be saved. The cursor must be in the upper left corner to enable screen advancement.

# Controller Navigation

Main Screen	
	↳ Unit Enable
<i>i</i>	↳ Information
<i>Set</i>	↳ System Control Point

Main Menu	
<i>Password</i>	Will appear, the Default Password is <b>1945</b> . <b>Note:</b> Password can be changed in the Settings Menu.
<i>Input/Output</i>	↳ Current I/O values <b>Note:</b> The Input/Output menu is read-only. The status screens are displayed depending on the I/O configuration.
<i>BMS Settings</i>	↳ Protocol Setup <b>Note:</b> Additional screens are displayed depending on the BMS protocol selected.
<i>Device Status</i>	↳ Fan(s) list <b>Note:</b> List of fans displayed is dependent on the number of fans set in the Array Setup screen.
<i>Device Config</i>	↳ Individual Fan Configuration <b>Note:</b> List of Fans displayed is dependent on the number of fans set in the Array Setup screen.
<i>Unit Config</i>	↳ Unit Setup
	↳ Communication Loss
	↳ PID Config
	↳ I/O Config
<i>Alarm Logs</i>	
<i>Settings</i>	↳ Date/Time
	↳ Unit of Measure (UoM)
	↳ Language
	↳ Network
	↳ Password Change
	↳ Initialization
<i>Logout</i>	



## Main Screen

The main screen displays the current state of the system:

Current pressure at the array

Current speed of the motors

Status of the unit – Hand, Off by Keyboard/HOA, Auto



### Unit Enable

*Unit Enable* menu allows the user to enable and disable the unit through the controller.

Use the  $\uparrow$   $\downarrow$  buttons to scroll through the quick menu symbols displayed at the lower right corner of the screen. Press the  $\leftarrow$  button when the  $\text{⏻}$  icon is displayed.

Change to (ON/OFF): Enables the user to manually turn unit on/off via display using the  $\uparrow$   $\downarrow$  buttons to change the state and press  $\leftarrow$ .

### Set

*Set* menu allows the user to set the system run point for the array. This setting is the pressure that the controller will maintain locally when the unit is put into Auto mode while using the provided pressure transducer.

Use the  $\uparrow$   $\downarrow$  buttons to scroll through the quick menu symbols displayed at the lower right corner of the screen. Press the  $\leftarrow$  button when the **Set** icon is displayed.

Set Point – Static pressure value at the array that the system will maintain at the array.

Offset – adjustment to the set point if the reading from the pressure transducer does not match a test reading at the array. Allows the user to adjust the set point without changing the set value.



### NOTE

This setting is not applicable if a remote sensor is being utilized.

### Information

The Information pages provide the firmware and software information for the controller.

# Menu

The controller is equipped with several menus to help guide users with altering program parameters. The following menus can be accessed by pressing the  button. To enter the desired menu, press the  button.

## Unit Config

The Unit Config menu allows the user to view and adjust unit control parameters.

The settings in this menu are required for the startup of the array system. All field wire connections shall be completed prior to modifying any settings in the Unit Config menu.

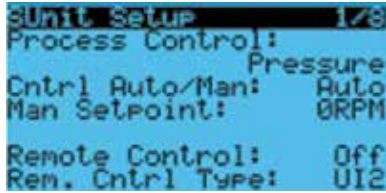

### Unit Setup

*Unit Setup* selections are utilized to set the parameters for control of the array.

#### Set Point Selections:

**Process Control** – Set the type of control transducer will be used. The control type selected dictates the displayed units for the process set point. Pressure is the default selection as the factory settings are to utilize the provided pressure transducer to control the speed of the fans.

Pressure – Set control set point units to inches of water column (in. wg).

Temperature – Set control set point units to degrees Fahrenheit (°F).

Flow – Set the control set point units to cubic feet per minute (CFM).

Volatile Organic Compounds (VOC) – Set the set point units to mg.

Remote – Remove the units from control set point.

**Control Auto/Manual** – Allows the controller to override the Hand/Off/Auto (HOA) switch located on the door of the panel. Default operation is Auto.

**Manual Set Point** – Set the speed at which the fans will operate if the HOA is moved to the Hand position.

**Remote Control** – Enable the use of a Universal Input (UI) to dictate the speed at which the fans operate based on a remote sensor within the building system. To control the unit with a remote signal, the Remote control needs to be ON.

**Remote Control Type** – Change the remote signal input source from an analog signal attached to UI2 (Location 2 on the terminal strip) to a BMS signal.

### Setup – Fan Cont.

*Setup – Fan Cont.* selections are made to ensure the controller is configured to match the installed array.

#### Set Point Selections:

**Number of Fans** – The controller is programmed to control up to 64 fans on any given installation. The selected value must equal the number of fans installed in the array. See submittal for exact information.

**Fan Type** – Update the controller with the type of motor installed on the array. Default value is Ziehlabegg. This parameter will not need to be changed.

**Fan Size** – Two sizes of wheels are available for the MOA, 400 mm and 560 mm. The variable must be changed to match the size fan for the installation. See submittal for exact information

**Fan Display Units** – Setting allows for the speed of the fans to be set to one of three options: RPM, Hz, or %. Adjusting is at the discretion of the user.

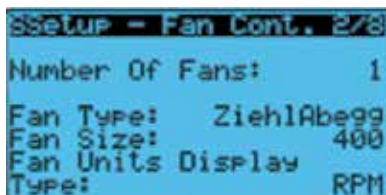

---

### Setup – Comm Loss

---

*Comm Loss Mode* selections are utilized to set the actions of the motors if communication is lost between the microprocessor and the motors.

Set Point Selections:

*Speed* – Input to set the speed of the fans, range zero to maximum RPM.

*Lag Time* – Set the amount of time, in seconds, required before the motors ramp to the set speed.

*Set Values* – Set and enable the speed and lag time values into the program.

```
3Setup - Comm. Loss 3/8
Comm. Loss Mode
Speed:          500rpm
Lag Time:      5s
Set Values:    Off
```

**NOTE**

Communication Loss mode is not enabled by default. If the command is not needed, settings do not need to be adjusted and can be skipped. If enabled, the motors will return to the initial set point automatically when communication is restored.

---

### Setup – PID

---

*Setup PID* selections allow for onsite adjustments to the PID loop for the provided pressure transducer as well as adjustments to the minimum and maximum RPM of the motors

```
3Setup - PID 4/8
Gain:          5.0
Integral:      10
Derivative:    1
Fan Min RPM:  0
Fan Max RPM:  3160
```

**NOTE**

It is recommended that the setting for min and max RPM not be adjusted, allowing the controller to have the full range of speed available to adjust the speed of the motors to account for unexpected changes within the system.



---

## Setup – IO

---

Setup IO is a series of pages that contain selections for the field wire inputs and outputs for the microprocessor.

### Available Field Inputs:

Pressure/flow reference  
Speed override  
Safety input  
Start/stop input  
Fireman override (input)  
Ready/run output  
Alarm output

### Set Point Selections:

UI1 Settings – This selection allows for a read-only output from a remote sensor to be displayed at the controller.

**UI1 Enabled** activates the input.

Alarm will trigger if no signal is found on the input and the input is active.

**Input Min/Max** values for the system must be set per the system requirements.

**Input Type** allows for a 0-10VDC or 4-20 mA signal input.

---

```
3Setup - IO 5/8
UI1 Settings
UI1 Enabled: Yes
Pressure In: 0.0inH2O
Pressure In: 8.0inH2O
UI1 Input Type:4-20mA
```

UI2 Settings – This selection allows for an input from a remote sensor to control the fans. For use with an existing sensor located away from the array.

**UI2 Enabled** activates the input.

**Input Min/Max** values for the system default to 0 and 100%, respectively.

**Input Type** allows for a 0-10VDC or 4-20 mA signal input.

```
3Setup - IO 6/8
UI2 Settings
UI2 Enabled: Yes
UI2 Min: 0.0%
UI2 Max: 100.0%
UI2 Input Type:0-10VDC
```



UI3 Settings – This selection sets the control parameters for the provided pressure transducer. The array is rated for a pressure range of 0-8 in. wg. The minimum and maximum values can be set to limit the pressure in the system.

*UI3 Enabled* activates the input.

*Input Min/Max* values can be adjusted to the rating for the system the array is installed. **Do not exceed 8.0 in. wg.**

*Input Type* allows for a 0-10VDC or 4-20 mA signal input. When using the provided pressure transducer, the input type must be set to 4-20mA.



Digital IO Settings – This selection screen displays and activates the field inputs for the controller. If an input is going to be utilized for the installation, it will need to be activated on this screen. See Field Inputs for more information.

## Alarms

The Alarms menu allows the user to view active alarms, reset active alarms and view, clear or export the alarm history.

Alarm Logs is a list of past or active alarm codes. Menu can be accessed through the Main Menu or by pressing the button. To clear the alarm list, press and hold the button for three seconds.

## Settings

Settings is a series of selections to update the visualizations on the microprocessor screens.

---

### Date/Time



Allows the user to set the date and time format.

---

### Unit of Measure (UoM)

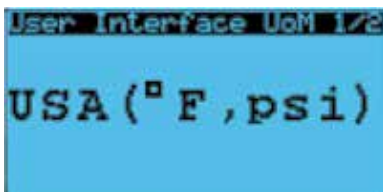

At the User Interface UoM screen, units displayed on the microprocessor screen can be changed to match the requirements of the user.

---

### Language



User can change the display language of the microprocessor by pressing the button to cycle through the options and pressing the button to confirm.

---

### Network

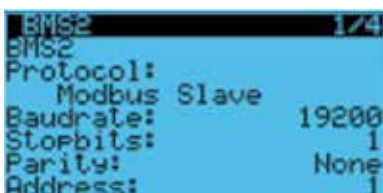

Settings for the controller can be modified, if needed, to match the requirements of the system.

*BMS Settings* – Communication settings can be updated to match the needs of the BMS.





## Password Change

The factory set password can be updated by the user. It is recommended to not change the Manufacturer password.

## Logout

Logout ends the session when selected and access to the Main Menu will require the password to be reentered.

### NOTE

The microprocessor will time out and log out of the Main Menu after inactivity.

## Input/Output

Display the status information of the inputs and outputs of the system to the controller.





The Input/Output screens are read-only displays showing the status of the analog and digital inputs. Only the inputs and outputs activated in the Unit Config menu will display on the Input/Output list. Included in the list of statuses are the Hand and Auto modes.

## BMS Settings

The BMS Settings menu allows the user to view and adjust the controller BMS settings.

The settings in this menu are required for BMS communication. The parameter screens will change based on the protocol selected by the user.

### To change BMS parameters:

Move cursor to desired parameter by pressing the  button. Press the   buttons to adjust the parameter. Press the  button to accept adjusted value.

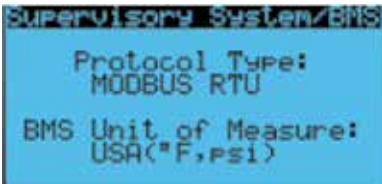

## Protocol Selection

This setting allows the user to select the communication protocol for the BMS. Unit of measure for BMS communication can also be set.



## Modbus RTU Parameters

This screen only appears if the selected BMS protocol is set to Modbus RTU. Factory settings are shown in the screen to the left.

Available on the J25 BMS2 port, the default communication settings are 19200 8N2 at address 1.



## Modbus TCP Parameters

This screen only appears if the selected BMS protocol is set to Modbus TCP. Factory defaults are shown in the screen to the left.

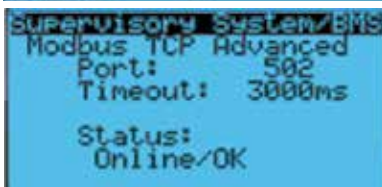

```
Supervisory System/BMS
Device Inst:
BACnet MS/TP Settings
Address: 009
Baud Rate: 19200
Max Master: 005
Max Info Frames: 005
```

### BACnet MS/TP Parameters

This screen only appears if the selected BMS protocol is set to BACnet MS/TP. Factory defaults are shown to the left.

Available on the J25 BMS2 port, the default device instance is 77000, baud rate is 19200, Mac address is 1, max Masters is 127, and Max Info Frames is 10.

```
Supervisory System/BMS
Device Inst:
BACnet IP Advanced
Port:
Timeout: ms
Cmd Timeout: ms
Status: Online/OK
Last Error:
```

### BACnet IP Parameters

This screen only appears if the selected BMS protocol is set to BACnet IP. Factory defaults are shown to the left.

Available from the Ethernet port, the controllers IP, Netmask, Gateway, and DNS settings can be set up to work with the applicable network. The default device instance is 77000 and the port is 47808.

## Device Status

The **Device Status** screens provide information for each fan in the array.

In the Device Status menu all fans in the array will be listed. The quantity of fans will update to match the value entered in the Unit Config menu. The screens under each fan are laid out identically and provide the same type of read only information. Six screens show varying information about an individual fan in the array.

### Information shown:

- |                         |                  |
|-------------------------|------------------|
| Speed                   | Motor current    |
| Product information     | RMS line voltage |
| Unique device signature | Current power    |

## Device Config

The **Device Config** menu allows the user to view and adjust motor parameters.

The settings in this menu are intended to control each fan in the array individually. Normal operation will not require any changes to the parameters in the Device Config menu.

```
Fan Config 1 1/5
Fan 1 Enable: YES
Speed ctrl mode: rpm
```

### Fan Config

Fan Enable – allows the user to disable a fan in the array.

Speed Control Mode – set the control units for a fan to RPM or %. This is only for communication from the controller.

```
Fan Config 1 2/5
Speed Suppression
Range 1: DISABLED
Min: 0rpm
Max: 0rpm
```

### Speed Suppression

Allows the user to set an RPM range for the individual fan that the program will not run. This is to be used only if there are system concerns with the fans operating at certain speeds.

```
Fan Config 1 3/5
Fan address: 1
Enable procedure for
changing the fan
address: ---
Check condition
```

### Fan Addressing

Shows the address of the fan and allows the user to change the address of an individual fan in the array.

### NOTE

Changes to the address may cause alarms if the address is the same as another fan in the array or not continuous with the other fan addresses.

```
Fan Config 1 4/5
Fan baudrate: 19200
Fan parity cfg: 8E1
Enable changing
interface settings: ---
Check condition
```

### Communication Protocol Settings







Displays the communication protocol information for the fan. The settings displayed are factory default.









## Touch Screen Display Use

The pGDx is an optional display mounted on the cover of the control panel. The display has its own HMI to simplify the configuration of the array parameters, but allows identical access to the menus and screens found on the mounted control display.

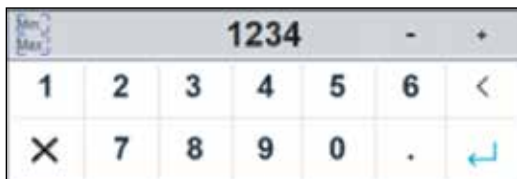
Touch Screen Key Description		
Button	Description	Functions
	Home	Press to go directly to the home screen from any menu location.
	Alarm	Press to go directly to the alarm log.
	Settings	Press to go directly to the Main Menu from any screen. A password screen will appear the first time the button is pressed or if the session has timed out. Default password: <b>1945</b>
	Back	Press to go to the last screen visited.
	Next	Press to move to the next screen in a menu.
	Previous	Press to move to the previous screen in a menu.
	Logout	Press to logout of the session. Will require the password to be reentered to enter the menus.





For menu selections that require an input value, when the selection box is touched, a popup keypad will appear on the screen.



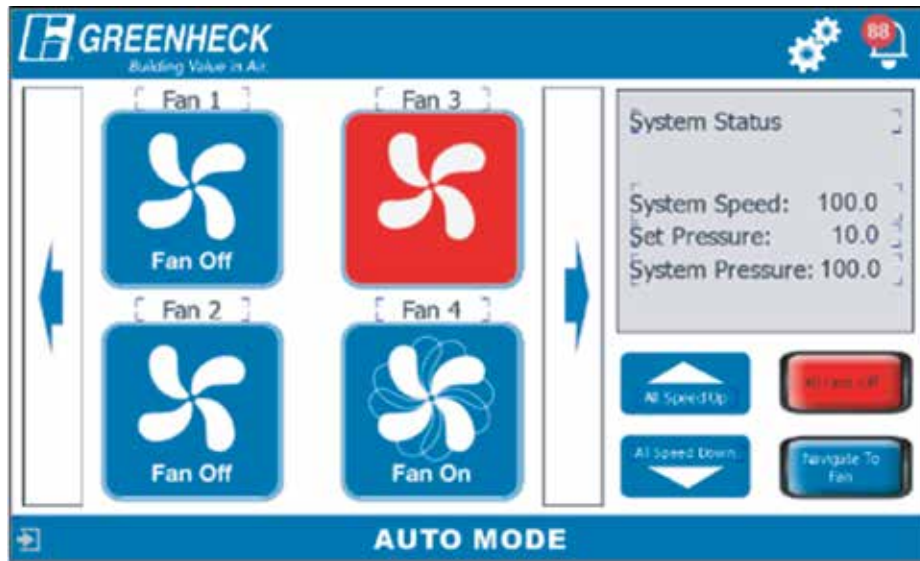



Popup Keypad Navigation		
Button	Description	Functions
	Cancel	Allows the user to close the keypad without saving the entered value.
	Backspace	Allows the user to erase previously entered values.
	Enter	Allows the user to save changes and close the keypad.

# Home Screen

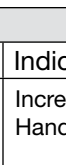

The Home Screen of the touch display interface will display the fans in the MOA system in groups of four. If there are more than four fans in the array, use the   buttons to navigate to the other fan icons. The icons on the Home Screen provide visual feedback on the status of each fan. The Home Screen also provides status information for the system. Depending on the mode that the controller is in, Auto or Hand, certain buttons will be available on the screen. When the controller is placed in Hand mode   buttons will appear on the screen allowing the user to increase or decrease the speed of the fan.

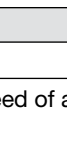
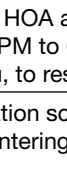
Unit Status Symbols			
Symbol	Indicates	Symbol	Indicates
	Fan Off		Increase speed of all fans when controller is in Hand mode.
	Fan On		Reduce speed of all fans when controller is in Hand mode.
	Fan in Alarm		Override the HOA and sets controller to Manual mode and RPM to 0. See Unit Setup, under Unit Config menu, to reset the controller to Auto mode.
			Open navigation screen to quickly view the status of a fan by entering ID of desired fan.

# Menu

The HMI is equipped with several menus to help guide users with altering program parameters.

To enter the menu screen for the HMI, press the  button.



## Login

The Login screen will appear after pressing the  button the first time the menu is accessed or after the session has timed out. If desired, the password can be changed in the Systems setting menu.

Default password: **1945**

## Array Settings

The **Array Settings** allows the user to view and adjust the unit control parameters.

Array Settings sets the parameters needed to configure the program to match the array installed.

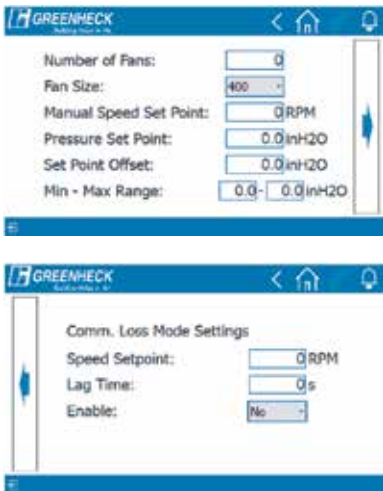

## Array Settings

Array sets the parameters needed to configure the program to match the array installed.

**Number of Fans** – The controller is programmed to control up to 64 fans on any given installation. The selected value must equal the number of fans installed in the array. See submittal for exact information.

**Fan Size** – Two sizes of wheels are available for the MOA, 400 mm and 560 mm. The variable must be changed to match the size fan for the installation. See submittal for exact information.

**Manual Set Point** – Set the speed at which the fans will operate if the HOA is moved to the *Hand* position.

**Pressure Set Point** – Static pressure value at the array that the system will maintain at the array.

**Set Point Offset** – Adjustment to the set point if the reading from the pressure transducer does not match a test reading at the array. Will allow the user to adjust the set point without changing the set value.

**Min – Max Range** – Set values for the minimum and maximum pressure for the system. Values to be adjusted to the rating for the system the array is installed. **Do not exceed 8.0 in. wg.**

**Comm Loss Mode** selections are utilized to set the actions of the motors if communication is lost between the microprocessor and the motors.

Set Point Selections:

**Speed Set Point** – Input to set the speed of the fans, range zero to maximum RPM.

**Lag Time** – Set the amount of time, in seconds, required before the motors ramp to the set speed.

**Enable** – Set and enable the speed and lag time values into the program.





### NOTE

Communication Loss mode is not enabled by default. If the command is not needed, no settings need to be adjusted and can be skipped. If enabled, the motors will return to the initial set point automatically once communication is restored.

## System Settings

The **System Settings** screens allow for changes to the communication protocol.

The settings in this menu are required for BMS communication. The parameter screens will change based on the protocol selected by the user.

System Setting Buttons			
Button	Function	Button	Function
	Open Terminal screen that mirrors the screen on the mounted controller.		Open popup screen to allow the user to change the password.
	Open the screen to modify the IP parameters for the controller.		Save all changes made on the screen.

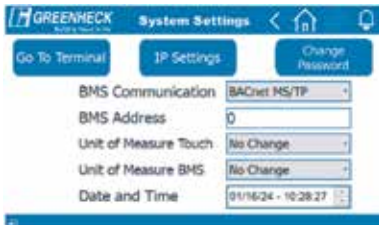

To change BMS parameters:

Touch the blue highlighted box to select or enter a value.

**Protocol Selection** – This setting allows the user to select the communication protocol for the BMS. Four options are available for the microprocessor:

- Modbus RTU
- Modbus TCP
- BACnet MS/TP
- BACnet IP

Unit of measure for touch screen and BMS communication can also be set.

Terminal screen has the same menu structure and functions as the controller described in the above microprocessor navigation and settings sections.

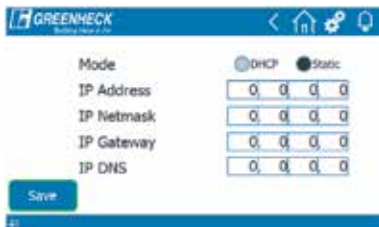

## Alarm Logs

View current and past alarms in the system.

Alarm Logs list past or active alarm codes. Menu can be accessed through the Main Menu or by pressing the  button.



## BACnet Settings

View and modify BACnet communication protocols.

The settings in this menu are required for BMS communication. The parameter screens will change based on the protocol selected by the user.

**BACnet MSTP** – The default device instance is 77000, baud rate is 19200, Mac address is 1, Max Masters is 127, and Max Info Frames is 10.

**BACnet IP** – The controllers IP, Netmask, Gateway, and DNS settings can be set up to work with the applicable network. The default device instance is 77000 and the port is 47808.

# Fan Status

On the Home Screen, icons for each fan will be present.

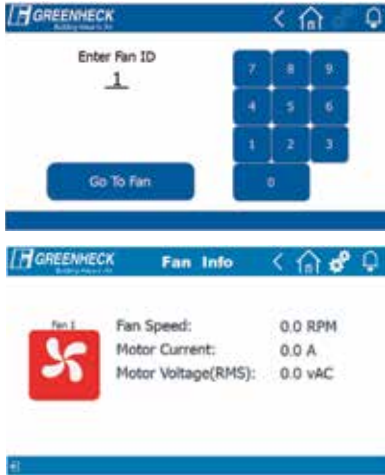

## Fan Info

The *Fan Info* screen provides some basic information for the motor.

### Information shown:

- Speed
- Motor current
- RMS line voltage

# Troubleshooting

General		
Issue	Possible Cause	Recommended Action
No communication to fans	CAT5 cable not connected	Check cable connection on the control panel. Check cable connection at each motor.
	Broken wire in CAT5 cable	Connect controller to next motor in line until communication is established. Replace cable for motors that are not communicating.
	Motor ID incorrect	Contact factory for assistance.
Unstable fan conditions, fan is not balancing the system and continues to change speed.	BMS PID timing incorrect	Increase time functions in the system.
	BMS PID overlap incorrect	Create an increased dead band between PID for fan and bypass.
	BMS fan control not working properly	Check BMS control and determine if condition is occurring at full speed and bypass is closed.
	Duct pressure transducer failure	Verify power and signal at duct pressure transducer(s).
System has an unfavorable, negative pressure condition.	BMS fan control not working properly	Check BMS control and determine if condition is occurring at fan low speed and bypass full open.
	Duct pressure transducer failure	Verify power and signal at duct pressure transducer(s).
Pressure reading is low or at zero even though the fan is operating.	Sure-Aire tubing leak or blockage	Inspect tubing and blow out tubing with air.
	Sure-Aire tube lines hooked up backwards	Flip the high and low tube lines.
	Sure-Aire transducer for system is bad	Test voltage with meter for 24 V and output signal.

General System Failure Mode
If communication is lost from the BMS, the controller will take over control of the system and maintain the most recent settings until communication is restored.
If communication is lost from the controller, the motors will, by default, maintain the current RPM setting until communication is restored.

# Appendix A: Power and Control Box Interconnect Drawing

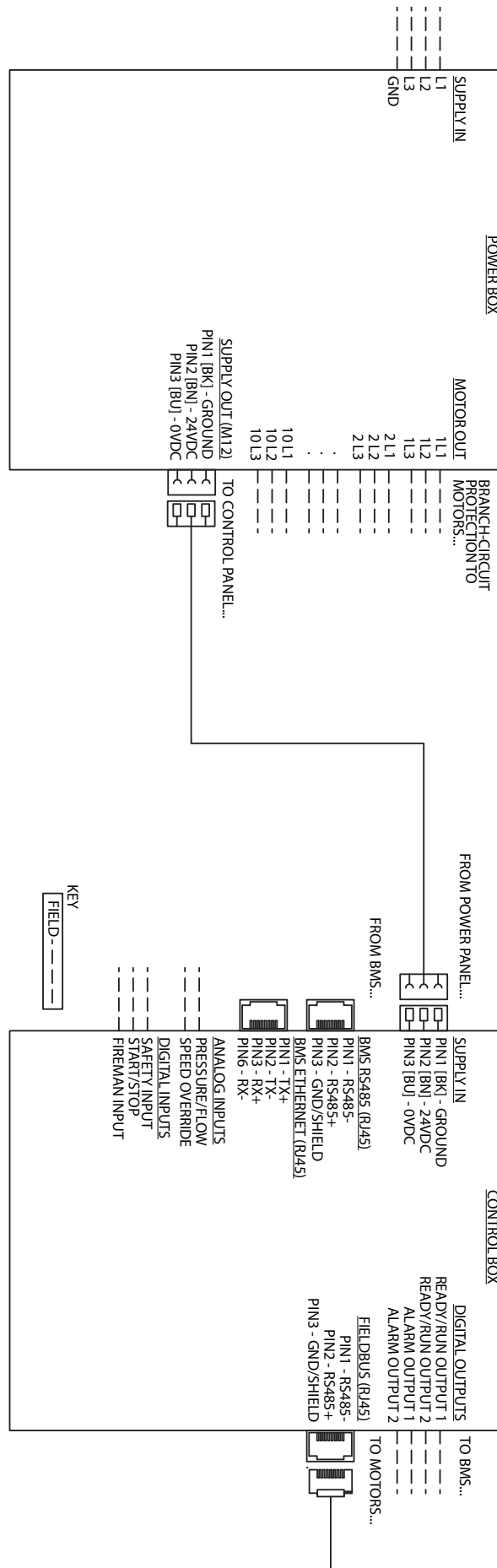





# OPTIONAL 7-INCH TOUCH SCREEN

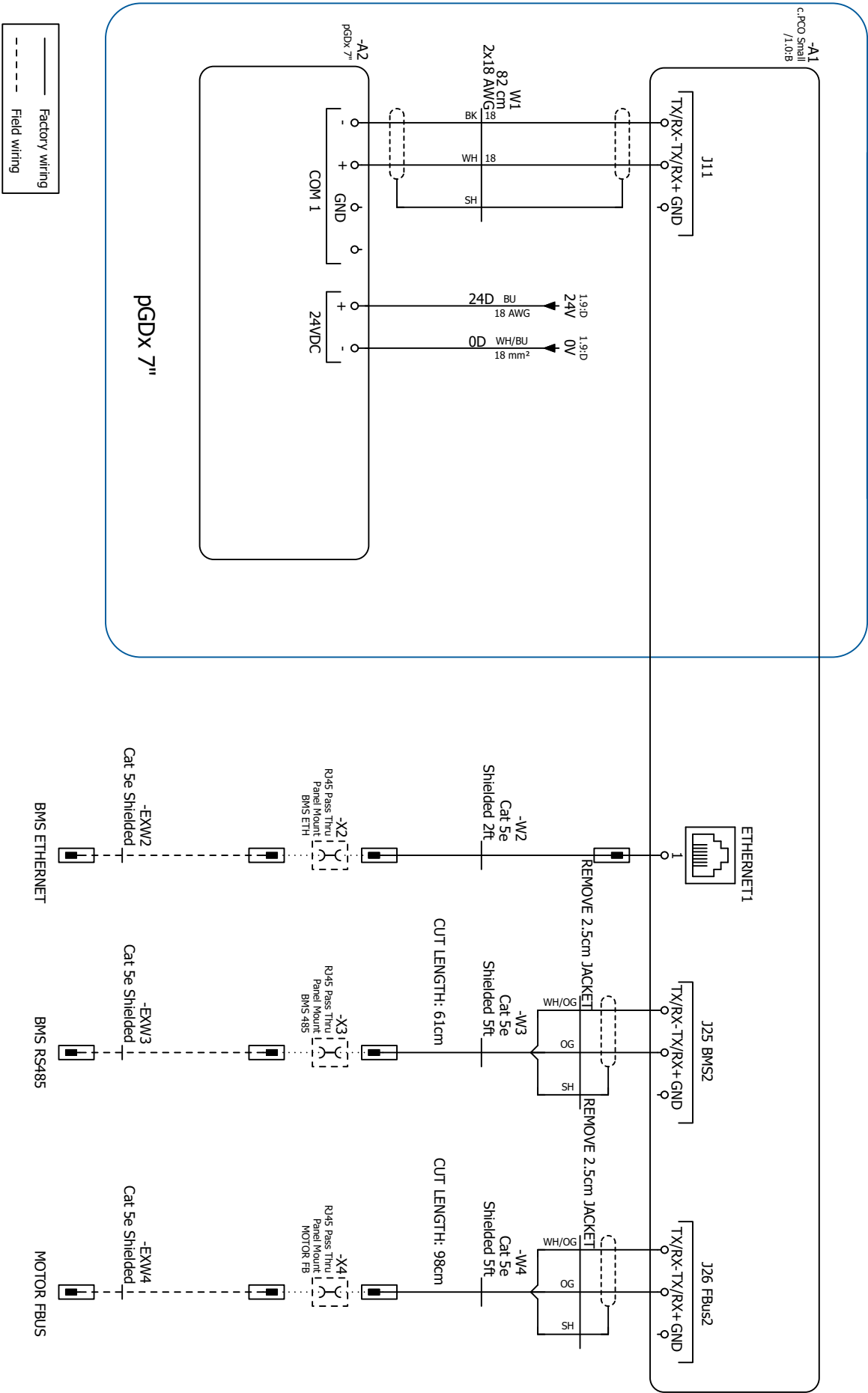

## Appendix C: Points List

Analog Values										
Variable	Description	Active Text	Inactive Text	BACnet				MODBUS		
				Object Instance	Object Type	Access	Hyst	Index	Register Type	Size
Fan_Output	Fan Percent output			1	AV	Read/Write	0			
Press_Setpt	Pressure Setpt			2	AV	Read/Write	0	30002	Holding	2
Remote_Control_BMS_Val	Remote control value by BMS			3	AV	Read/Write	0	30010	Holding	2
Output_Disp_pGDx	Overall output display for pGDx			4	AV	Read/Write	0	30013	Holding	2
BMS_Fan_Current[1]	Current Draw Fan 1			132	AV	Read	0	40004	Input	2
BMS_Fan_Current[2]	Current Draw Fan 2			133	AV	Read	0	40006	Input	2
BMS_Fan_Current[3]	Current Draw Fan 3			134	AV	Read	0	40008	Input	2
BMS_Fan_Current[4]	Current Draw Fan 4			135	AV	Read	0	40010	Input	2
BMS_Fan_Current[5]	Current Draw Fan 5			136	AV	Read	0	40012	Input	2
BMS_Fan_Current[6]	Current Draw Fan 6			137	AV	Read	0	40014	Input	2
BMS_Fan_Current[7]	Current Draw Fan 7			138	AV	Read	0	40016	Input	2
BMS_Fan_Current[8]	Current Draw Fan 8			139	AV	Read	0	40018	Input	2
BMS_Fan_Current[9]	Current Draw Fan 9			140	AV	Read	0	40020	Input	2
BMS_Fan_Current[10]	Current Draw Fan 10			141	AV	Read	0	40022	Input	2
BMS_Fan_Current[11]	Current Draw Fan 11			142	AV	Read	0	40024	Input	2
BMS_Fan_Current[12]	Current Draw Fan 12			143	AV	Read	0	40026	Input	2
BMS_Fan_Current[13]	Current Draw Fan 13			144	AV	Read	0	40028	Input	2
BMS_Fan_Current[14]	Current Draw Fan 14			145	AV	Read	0	40030	Input	2
BMS_Fan_Current[15]	Current Draw Fan 15			146	AV	Read	0	40032	Input	2
BMS_Fan_Current[16]	Current Draw Fan 16			147	AV	Read	0	40034	Input	2
BMS_Fan_Current[17]	Current Draw Fan 17			148	AV	Read	0	40036	Input	2
BMS_Fan_Current[18]	Current Draw Fan 18			149	AV	Read	0	40038	Input	2
BMS_Fan_Current[19]	Current Draw Fan 19			150	AV	Read	0	40040	Input	2
BMS_Fan_Current[20]	Current Draw Fan 20			151	AV	Read	0	40042	Input	2
BMS_Fan_Current[21]	Current Draw Fan 21			152	AV	Read	0	40044	Input	2

Variable	Description	Active Text	Inactive Text	BACnet				MODBUS		
				Object Instance	Object Type	Access	Hyst	Index	Register Type	Size
BMS_Fan_Current[22]	Current Draw Fan 22			153	AV	Read	0	40046	Input	2
BMS_Fan_Current[23]	Current Draw Fan 23			154	AV	Read	0	40048	Input	2
BMS_Fan_Current[24]	Current Draw Fan 24			155	AV	Read	0	40050	Input	2
BMS_Fan_Current[25]	Current Draw Fan 25			156	AV	Read	0	40052	Input	2
BMS_Fan_Current[26]	Current Draw Fan 26			157	AV	Read	0	40054	Input	2
BMS_Fan_Current[27]	Current Draw Fan 27			158	AV	Read	0	40056	Input	2
BMS_Fan_Current[28]	Current Draw Fan 28			159	AV	Read	0	40058	Input	2
BMS_Fan_Current[29]	Current Draw Fan 29			160	AV	Read	0	40060	Input	2
BMS_Fan_Current[30]	Current Draw Fan 30			161	AV	Read	0	40062	Input	2
BMS_Fan_Current[31]	Current Draw Fan 31			162	AV	Read	0	40064	Input	2
BMS_Fan_Current[32]	Current Draw Fan 32			163	AV	Read	0	40066	Input	2
BMS_Fan_Current[33]	Current Draw Fan 33			164	AV	Read	0	40068	Input	2
BMS_Fan_Current[34]	Current Draw Fan 34			165	AV	Read	0	40070	Input	2
BMS_Fan_Current[35]	Current Draw Fan 35			166	AV	Read	0	40072	Input	2
BMS_Fan_Current[36]	Current Draw Fan 36			167	AV	Read	0	40074	Input	2
BMS_Fan_Current[37]	Current Draw Fan 37			168	AV	Read	0	40076	Input	2
BMS_Fan_Current[38]	Current Draw Fan 38			169	AV	Read	0	40078	Input	2
BMS_Fan_Current[39]	Current Draw Fan 39			170	AV	Read	0	40080	Input	2
BMS_Fan_Current[40]	Current Draw Fan 40			171	AV	Read	0	40082	Input	2
BMS_Fan_Current[41]	Current Draw Fan 41			172	AV	Read	0	40084	Input	2
BMS_Fan_Current[42]	Current Draw Fan 42			173	AV	Read	0	40086	Input	2
BMS_Fan_Current[43]	Current Draw Fan 43			174	AV	Read	0	40088	Input	2
BMS_Fan_Current[44]	Current Draw Fan 44			175	AV	Read	0	40090	Input	2
BMS_Fan_Current[45]	Current Draw Fan 45			176	AV	Read	0	40092	Input	2
BMS_Fan_Current[46]	Current Draw Fan 46			177	AV	Read	0	40094	Input	2
BMS_Fan_Current[47]	Current Draw Fan 47			178	AV	Read	0	40096	Input	2
BMS_Fan_Current[48]	Current Draw Fan 48			179	AV	Read	0	40098	Input	2

Variable	Description	Active Text	Inactive Text	BACnet				MODBUS		
				Object Instance	Object Type	Access	Hyst	Index	Register Type	Size
BMS_Fan_Current[49]	Current Draw Fan 49			180	AV	Read	0	40100	Input	2
BMS_Fan_Current[50]	Current Draw Fan 50			181	AV	Read	0	40102	Input	2
BMS_Fan_Current[51]	Current Draw Fan 51			182	AV	Read	0	40104	Input	2
BMS_Fan_Current[52]	Current Draw Fan 52			183	AV	Read	0	40106	Input	2
BMS_Fan_Current[53]	Current Draw Fan 53			184	AV	Read	0	40108	Input	2
BMS_Fan_Current[54]	Current Draw Fan 54			185	AV	Read	0	40110	Input	2
BMS_Fan_Current[55]	Current Draw Fan 55			186	AV	Read	0	40112	Input	2
BMS_Fan_Current[56]	Current Draw Fan 56			187	AV	Read	0	40114	Input	2
BMS_Fan_Current[57]	Current Draw Fan 57			188	AV	Read	0	40116	Input	2
BMS_Fan_Current[58]	Current Draw Fan 58			189	AV	Read	0	40118	Input	2
BMS_Fan_Current[59]	Current Draw Fan 59			190	AV	Read	0	40120	Input	2
BMS_Fan_Current[60]	Current Draw Fan 60			191	AV	Read	0	40122	Input	2
BMS_Fan_Current[61]	Current Draw Fan 61			192	AV	Read	0	40124	Input	2
BMS_Fan_Current[62]	Current Draw Fan 62			193	AV	Read	0	40126	Input	2
BMS_Fan_Current[63]	Current Draw Fan 63			194	AV	Read	0	40128	Input	2
BMS_Fan_Current[64]	Current Draw Fan 64			195	AV	Read	0	40130	Input	2
BMS_Fan_Voltage[1]	RMS Voltage Fan 1			196	AV	Read	0	40324	Input	2
BMS_Fan_Voltage[2]	RMS Voltage Fan 2			197	AV	Read	0	40326	Input	2
BMS_Fan_Voltage[3]	RMS Voltage Fan 3			198	AV	Read	0	40328	Input	2
BMS_Fan_Voltage[4]	RMS Voltage Fan 4			199	AV	Read	0	40330	Input	2
BMS_Fan_Voltage[5]	RMS Voltage Fan 5			200	AV	Read	0	40332	Input	2
BMS_Fan_Voltage[6]	RMS Voltage Fan 6			201	AV	Read	0	40334	Input	2
BMS_Fan_Voltage[7]	RMS Voltage Fan 7			202	AV	Read	0	40336	Input	2
BMS_Fan_Voltage[8]	RMS Voltage Fan 8			203	AV	Read	0	40338	Input	2
BMS_Fan_Voltage[9]	RMS Voltage Fan 9			204	AV	Read	0	40340	Input	2
BMS_Fan_Voltage[10]	RMS Voltage Fan 10			205	AV	Read	0	40342	Input	2
BMS_Fan_Voltage[11]	RMS Voltage Fan 11			206	AV	Read	0	40344	Input	2

Variable	Description	Active Text	Inactive Text	BACnet				MODBUS		
				Object Instance	Object Type	Access	Hyst	Index	Register Type	Size
BMS_Fan_Voltage[12]	RMS Voltage Fan 12			207	AV	Read	0	40346	Input	2
BMS_Fan_Voltage[13]	RMS Voltage Fan 13			208	AV	Read	0	40348	Input	2
BMS_Fan_Voltage[14]	RMS Voltage Fan 14			209	AV	Read	0	40350	Input	2
BMS_Fan_Voltage[15]	RMS Voltage Fan 15			210	AV	Read	0	40352	Input	2
BMS_Fan_Voltage[16]	RMS Voltage Fan 16			211	AV	Read	0	40354	Input	2
BMS_Fan_Voltage[17]	RMS Voltage Fan 17			212	AV	Read	0	40356	Input	2
BMS_Fan_Voltage[18]	RMS Voltage Fan 18			213	AV	Read	0	40358	Input	2
BMS_Fan_Voltage[19]	RMS Voltage Fan 19			214	AV	Read	0	40360	Input	2
BMS_Fan_Voltage[20]	RMS Voltage Fan 20			215	AV	Read	0	40362	Input	2
BMS_Fan_Voltage[21]	RMS Voltage Fan 21			216	AV	Read	0	40364	Input	2
BMS_Fan_Voltage[22]	RMS Voltage Fan 22			217	AV	Read	0	40366	Input	2
BMS_Fan_Voltage[23]	RMS Voltage Fan 23			218	AV	Read	0	40368	Input	2
BMS_Fan_Voltage[24]	RMS Voltage Fan 24			219	AV	Read	0	40370	Input	2
BMS_Fan_Voltage[25]	RMS Voltage Fan 25			220	AV	Read	0	40372	Input	2
BMS_Fan_Voltage[26]	RMS Voltage Fan 26			221	AV	Read	0	40374	Input	2
BMS_Fan_Voltage[27]	RMS Voltage Fan 27			222	AV	Read	0	40376	Input	2
BMS_Fan_Voltage[28]	RMS Voltage Fan 28			223	AV	Read	0	40378	Input	2
BMS_Fan_Voltage[29]	RMS Voltage Fan 29			224	AV	Read	0	40380	Input	2
BMS_Fan_Voltage[30]	RMS Voltage Fan 30			225	AV	Read	0	40382	Input	2
BMS_Fan_Voltage[31]	RMS Voltage Fan 31			226	AV	Read	0	40384	Input	2
BMS_Fan_Voltage[32]	RMS Voltage Fan 32			227	AV	Read	0	40386	Input	2
BMS_Fan_Voltage[33]	RMS Voltage Fan 33			228	AV	Read	0	40388	Input	2
BMS_Fan_Voltage[34]	RMS Voltage Fan 34			229	AV	Read	0	40390	Input	2
BMS_Fan_Voltage[35]	RMS Voltage Fan 35			230	AV	Read	0	40392	Input	2
BMS_Fan_Voltage[36]	RMS Voltage Fan 36			231	AV	Read	0	40394	Input	2
BMS_Fan_Voltage[37]	RMS Voltage Fan 37			232	AV	Read	0	40396	Input	2
BMS_Fan_Voltage[38]	RMS Voltage Fan 38			233	AV	Read	0	40398	Input	2

Variable	Description	Active Text	Inactive Text	BACnet				MODBUS		
				Object Instance	Object Type	Access	Hyst	Index	Register Type	Size
BMS_Fan_Voltage[39]	RMS Voltage Fan 39			234	AV	Read	0	40400	Input	2
BMS_Fan_Voltage[40]	RMS Voltage Fan 40			235	AV	Read	0	40402	Input	2
BMS_Fan_Voltage[41]	RMS Voltage Fan 41			236	AV	Read	0	40404	Input	2
BMS_Fan_Voltage[42]	RMS Voltage Fan 42			237	AV	Read	0	40406	Input	2
BMS_Fan_Voltage[43]	RMS Voltage Fan 43			238	AV	Read	0	40408	Input	2
BMS_Fan_Voltage[44]	RMS Voltage Fan 44			239	AV	Read	0	40410	Input	2
BMS_Fan_Voltage[45]	RMS Voltage Fan 45			240	AV	Read	0	40412	Input	2
BMS_Fan_Voltage[46]	RMS Voltage Fan 46			241	AV	Read	0	40414	Input	2
BMS_Fan_Voltage[47]	RMS Voltage Fan 47			242	AV	Read	0	40416	Input	2
BMS_Fan_Voltage[48]	RMS Voltage Fan 48			243	AV	Read	0	40418	Input	2
BMS_Fan_Voltage[49]	RMS Voltage Fan 49			244	AV	Read	0	40420	Input	2
BMS_Fan_Voltage[50]	RMS Voltage Fan 50			245	AV	Read	0	40422	Input	2
BMS_Fan_Voltage[51]	RMS Voltage Fan 51			246	AV	Read	0	40424	Input	2
BMS_Fan_Voltage[52]	RMS Voltage Fan 52			247	AV	Read	0	40426	Input	2
BMS_Fan_Voltage[53]	RMS Voltage Fan 53			248	AV	Read	0	40428	Input	2
BMS_Fan_Voltage[54]	RMS Voltage Fan 54			249	AV	Read	0	40430	Input	2
BMS_Fan_Voltage[55]	RMS Voltage Fan 55			250	AV	Read	0	40432	Input	2
BMS_Fan_Voltage[56]	RMS Voltage Fan 56			251	AV	Read	0	40434	Input	2
BMS_Fan_Voltage[57]	RMS Voltage Fan 57			252	AV	Read	0	40436	Input	2
BMS_Fan_Voltage[58]	RMS Voltage Fan 58			253	AV	Read	0	40438	Input	2
BMS_Fan_Voltage[59]	RMS Voltage Fan 59			254	AV	Read	0	40440	Input	2
BMS_Fan_Voltage[60]	RMS Voltage Fan 60			255	AV	Read	0	40442	Input	2
BMS_Fan_Voltage[61]	RMS Voltage Fan 61			256	AV	Read	0	40444	Input	2
BMS_Fan_Voltage[62]	RMS Voltage Fan 62			257	AV	Read	0	40446	Input	2
BMS_Fan_Voltage[63]	RMS Voltage Fan 63			258	AV	Read	0	40448	Input	2
BMS_Fan_Voltage[64]	RMS Voltage Fan 64			259	AV	Read	0	40450	Input	2



Binary Values										
Variable	Description	Active Text	Inactive Text	BACnet				MODBUS		
				Object Instance	Object Type	Access	Hyst	Index	Register Type	Size
OnOffUnitMng.BmsOnOff	Unit On/Off by BMS	ON	OFF	1	BV	Read/Write	0	10000	Coil	1
OnOffUnitMng.EnBmsOnOff	Unit On/Off by BMS	ON	OFF	2	BV	Read/Write	0	10001	Coil	1
Local_Remote_Cntl	"False - local mode, true -	REMOTE	LOCAL	3	BV	Read/Write	0	10007	Coil	1
Remote_Control_Type	0-U12, 1=BMS	BMS	U12	4	BV	Read/Write	0	10008	Coil	1
AI_Offline_ZA_1.Active	Offline ZA 1 - Alarm Status	ALARM	OK	20	BV	Read/Write	0	20000	Discrete	1
AI_Offline_ZA_2.Active	Offline ZA 2 - Alarm Status	ALARM	OK	21	BV	Read/Write	0	20001	Discrete	1
AI_Offline_ZA_3.Active	Offline ZA 3 - Alarm Status	ALARM	OK	22	BV	Read/Write	0	20002	Discrete	1
AI_Offline_ZA_4.Active	Offline ZA 4 - Alarm Status	ALARM	OK	23	BV	Read/Write	0	20003	Discrete	1
AI_Offline_ZA_5.Active	Offline ZA 5 - Alarm Status	ALARM	OK	24	BV	Read/Write	0	20004	Discrete	1
AI_Offline_ZA_6.Active	Offline ZA 6 - Alarm Status	ALARM	OK	25	BV	Read/Write	0	20005	Discrete	1
AI_Offline_ZA_7.Active	Offline ZA 7 - Alarm Status	ALARM	OK	26	BV	Read/Write	0	20006	Discrete	1
AI_Offline_ZA_8.Active	Offline ZA 8 - Alarm Status	ALARM	OK	27	BV	Read/Write	0	20007	Discrete	1
AI_Offline_ZA_9.Active	Offline ZA 9 - Alarm Status	ALARM	OK	28	BV	Read/Write	0	20008	Discrete	1
AI_Offline_ZA_10.Active	Offline ZA 10 - Alarm Status	ALARM	OK	29	BV	Read/Write	0	20009	Discrete	1
AI_Offline_ZA_11.Active	Offline ZA 11 - Alarm Status	ALARM	OK	30	BV	Read/Write	0	20010	Discrete	1
AI_Offline_ZA_12.Active	Offline ZA 12 - Alarm Status	ALARM	OK	31	BV	Read/Write	0	20011	Discrete	1
AI_Offline_ZA_13.Active	Offline ZA 13 - Alarm Status	ALARM	OK	32	BV	Read/Write	0	20012	Discrete	1
AI_Offline_ZA_14.Active	Offline ZA 14 - Alarm Status	ALARM	OK	33	BV	Read/Write	0	20013	Discrete	1
AI_Offline_ZA_15.Active	Offline ZA 15 - Alarm Status	ALARM	OK	34	BV	Read/Write	0	20014	Discrete	1
AI_Offline_ZA_16.Active	Offline ZA 16 - Alarm Status	ALARM	OK	35	BV	Read/Write	0	20015	Discrete	1
AI_Offline_ZA_17.Active	Offline ZA 17 - Alarm Status	ALARM	OK	36	BV	Read/Write	0	20016	Discrete	1
AI_Offline_ZA_18.Active	Offline ZA 18 - Alarm Status	ALARM	OK	37	BV	Read/Write	0	20017	Discrete	1
AI_Offline_ZA_19.Active	Offline ZA 19 - Alarm Status	ALARM	OK	38	BV	Read/Write	0	20018	Discrete	1



Variable	Description	Active Text	Inactive Text	BACnet				MODBUS		
				Object Instance	Object Type	Access	Hyst	Index	Register Type	Size
AI_Offline_ZA_20.Active	Offline ZA 20 - Alarm Status	ALARM	OK	39	BV	Read/Write	0	20019	Discrete	1
AI_Offline_ZA_21.Active	Offline ZA 21 - Alarm Status	ALARM	OK	40	BV	Read/Write	0	20020	Discrete	1
AI_Offline_ZA_22.Active	Offline ZA 22 - Alarm Status	ALARM	OK	41	BV	Read/Write	0	20021	Discrete	1
AI_Offline_ZA_23.Active	Offline ZA 23 - Alarm Status	ALARM	OK	42	BV	Read/Write	0	20022	Discrete	1
AI_Offline_ZA_24.Active	Offline ZA 24 - Alarm Status	ALARM	OK	43	BV	Read/Write	0	20023	Discrete	1
AI_Offline_ZA_25.Active	Offline ZA 25 - Alarm Status	ALARM	OK	44	BV	Read/Write	0	20024	Discrete	1
AI_Offline_ZA_26.Active	Offline ZA 26 - Alarm Status	ALARM	OK	45	BV	Read/Write	0	20025	Discrete	1
AI_Offline_ZA_27.Active	Offline ZA 27 - Alarm Status	ALARM	OK	46	BV	Read/Write	0	20026	Discrete	1
AI_Offline_ZA_28.Active	Offline ZA 28 - Alarm Status	ALARM	OK	47	BV	Read/Write	0	20027	Discrete	1
AI_Offline_ZA_29.Active	Offline ZA 29 - Alarm Status	ALARM	OK	48	BV	Read/Write	0	20028	Discrete	1
AI_Offline_ZA_30.Active	Offline ZA 30 - Alarm Status	ALARM	OK	49	BV	Read/Write	0	20029	Discrete	1
AI_Offline_ZA_31.Active	Offline ZA 31 - Alarm Status	ALARM	OK	50	BV	Read/Write	0	20030	Discrete	1
AI_Offline_ZA_32.Active	Offline ZA 32 - Alarm Status	ALARM	OK	51	BV	Read/Write	0	20031	Discrete	1
AI_Offline_ZA_33.Active	Offline ZA 33 - Alarm Status	ALARM	OK	52	BV	Read/Write	0	20032	Discrete	1
AI_Offline_ZA_34.Active	Offline ZA 34 - Alarm Status	ALARM	OK	53	BV	Read/Write	0	20033	Discrete	1
AI_Offline_ZA_35.Active	Offline ZA 35 - Alarm Status	ALARM	OK	54	BV	Read/Write	0	20034	Discrete	1
AI_Offline_ZA_36.Active	Offline ZA 36 - Alarm Status	ALARM	OK	55	BV	Read/Write	0	20035	Discrete	1
AI_Offline_ZA_37.Active	Offline ZA 37 - Alarm Status	ALARM	OK	56	BV	Read/Write	0	20036	Discrete	1
AI_Offline_ZA_38.Active	Offline ZA 38 - Alarm Status	ALARM	OK	57	BV	Read/Write	0	20037	Discrete	1
AI_Offline_ZA_39.Active	Offline ZA 39 - Alarm Status	ALARM	OK	58	BV	Read/Write	0	20038	Discrete	1

Variable	Description	Active Text	Inactive Text	BACnet				MODBUS		
				Object Instance	Object Type	Access	Hyst	Index	Register Type	Size
AI_Offline_ZA_40.Active	Offline ZA 40 - Alarm Status	ALARM	OK	59	BV	Read/Write	0	20039	Discrete	1
AI_Offline_ZA_41.Active	Offline ZA 41 - Alarm Status	ALARM	OK	60	BV	Read/Write	0	20040	Discrete	1
AI_Offline_ZA_42.Active	Offline ZA 42 - Alarm Status	ALARM	OK	61	BV	Read/Write	0	20041	Discrete	1
AI_Offline_ZA_43.Active	Offline ZA 43 - Alarm Status	ALARM	OK	62	BV	Read/Write	0	20042	Discrete	1
AI_Offline_ZA_44.Active	Offline ZA 44 - Alarm Status	ALARM	OK	63	BV	Read/Write	0	20043	Discrete	1
AI_Offline_ZA_45.Active	Offline ZA 45 - Alarm Status	ALARM	OK	64	BV	Read/Write	0	20044	Discrete	1
AI_Offline_ZA_46.Active	Offline ZA 46 - Alarm Status	ALARM	OK	65	BV	Read/Write	0	20045	Discrete	1
AI_Offline_ZA_47.Active	Offline ZA 47 - Alarm Status	ALARM	OK	66	BV	Read/Write	0	20046	Discrete	1
AI_Offline_ZA_48.Active	Offline ZA 48 - Alarm Status	ALARM	OK	67	BV	Read/Write	0	20047	Discrete	1
AI_Offline_ZA_49.Active	Offline ZA 49 - Alarm Status	ALARM	OK	68	BV	Read/Write	0	20048	Discrete	1
AI_Offline_ZA_50.Active	Offline ZA 50 - Alarm Status	ALARM	OK	69	BV	Read/Write	0	20049	Discrete	1
AI_Offline_ZA_51.Active	Offline ZA 51 - Alarm Status	ALARM	OK	70	BV	Read/Write	0	20050	Discrete	1
AI_Offline_ZA_52.Active	Offline ZA 52 - Alarm Status	ALARM	OK	71	BV	Read/Write	0	20051	Discrete	1
AI_Offline_ZA_53.Active	Offline ZA 53 - Alarm Status	ALARM	OK	72	BV	Read/Write	0	20052	Discrete	1
AI_Offline_ZA_54.Active	Offline ZA 54 - Alarm Status	ALARM	OK	73	BV	Read/Write	0	20053	Discrete	1
AI_Offline_ZA_55.Active	Offline ZA 55 - Alarm Status	ALARM	OK	74	BV	Read/Write	0	20054	Discrete	1
AI_Offline_ZA_56.Active	Offline ZA 56 - Alarm Status	ALARM	OK	75	BV	Read/Write	0	20055	Discrete	1
AI_Offline_ZA_57.Active	Offline ZA 57 - Alarm Status	ALARM	OK	76	BV	Read/Write	0	20056	Discrete	1
AI_Offline_ZA_58.Active	Offline ZA 58 - Alarm Status	ALARM	OK	77	BV	Read/Write	0	20057	Discrete	1
AI_Offline_ZA_59.Active	Offline ZA 59 - Alarm Status	ALARM	OK	78	BV	Read/Write	0	20058	Discrete	1

Variable	Description	Active Text	Inactive Text	BACnet				MODBUS		
				Object Instance	Object Type	Access	Hyst	Index	Register Type	Size
AI_Offline_ZA_60.Active	Offline ZA 60 - Alarm Status	ALARM	OK	79	BV	Read/Write	0	20059	Discrete	1
AI_Offline_ZA_61.Active	Offline ZA 61 - Alarm Status	ALARM	OK	80	BV	Read/Write	0	20060	Discrete	1
AI_Offline_ZA_62.Active	Offline ZA 62 - Alarm Status	ALARM	OK	81	BV	Read/Write	0	20061	Discrete	1
AI_Offline_ZA_63.Active	Offline ZA 63 - Alarm Status	ALARM	OK	82	BV	Read/Write	0	20062	Discrete	1
AI_Offline_ZA_64.Active	Offline ZA 64 - Alarm Status	ALARM	OK	83	BV	Read/Write	0	20063	Discrete	1

Integer Values										
Variable	Description	Active Text	Inactive Text	BACnet				MODBUS		
				Object Instance	Object Type	Access	Hyst	Index	Register Type	Size
BMS_Fan_Speed[1]	Speed of Fan 1			68	IV	Read	0	40196	Input	2
BMS_Fan_Speed[2]	Speed of Fan 2			69	IV	Read	0	40198	Input	2
BMS_Fan_Speed[3]	Speed of Fan 3			70	IV	Read	0	40200	Input	2
BMS_Fan_Speed[4]	Speed of Fan 4			71	IV	Read	0	40202	Input	2
BMS_Fan_Speed[5]	Speed of Fan 5			72	IV	Read	0	40204	Input	2
BMS_Fan_Speed[6]	Speed of Fan 6			73	IV	Read	0	40206	Input	2
BMS_Fan_Speed[7]	Speed of Fan 7			74	IV	Read	0	40208	Input	2
BMS_Fan_Speed[8]	Speed of Fan 8			75	IV	Read	0	40210	Input	2
BMS_Fan_Speed[9]	Speed of Fan 9			76	IV	Read	0	40212	Input	2
BMS_Fan_Speed[10]	Speed of Fan 10			77	IV	Read	0	40214	Input	2
BMS_Fan_Speed[11]	Speed of Fan 11			78	IV	Read	0	40216	Input	2
BMS_Fan_Speed[12]	Speed of Fan 12			79	IV	Read	0	40218	Input	2
BMS_Fan_Speed[13]	Speed of Fan 13			80	IV	Read	0	40220	Input	2
BMS_Fan_Speed[14]	Speed of Fan 14			81	IV	Read	0	40222	Input	2
BMS_Fan_Speed[15]	Speed of Fan 15			82	IV	Read	0	40224	Input	2
BMS_Fan_Speed[16]	Speed of Fan 16			83	IV	Read	0	40226	Input	2
BMS_Fan_Speed[17]	Speed of Fan 17			84	IV	Read	0	40228	Input	2
BMS_Fan_Speed[18]	Speed of Fan 18			85	IV	Read	0	40230	Input	2
BMS_Fan_Speed[19]	Speed of Fan 19			86	IV	Read	0	40232	Input	2
BMS_Fan_Speed[20]	Speed of Fan 20			87	IV	Read	0	40234	Input	2
BMS_Fan_Speed[21]	Speed of Fan 21			88	IV	Read	0	40236	Input	2
BMS_Fan_Speed[22]	Speed of Fan 22			89	IV	Read	0	40238	Input	2
BMS_Fan_Speed[23]	Speed of Fan 23			90	IV	Read	0	40240	Input	2
BMS_Fan_Speed[24]	Speed of Fan 24			91	IV	Read	0	40242	Input	2
BMS_Fan_Speed[25]	Speed of Fan 25			92	IV	Read	0	40244	Input	2
BMS_Fan_Speed[26]	Speed of Fan 26			93	IV	Read	0	40246	Input	2
BMS_Fan_Speed[27]	Speed of Fan 27			94	IV	Read	0	40248	Input	2

Variable	Description	Active Text	Inactive Text	BACnet				MODBUS		
				Object Instance	Object Type	Access	Hyst	Index	Register Type	Size
BMS_Fan_Speed[28]	Speed of Fan 28			95	IV	Read	0	40250	Input	2
BMS_Fan_Speed[29]	Speed of Fan 29			96	IV	Read	0	40252	Input	2
BMS_Fan_Speed[30]	Speed of Fan 30			97	IV	Read	0	40254	Input	2
BMS_Fan_Speed[31]	Speed of Fan 31			98	IV	Read	0	40256	Input	2
BMS_Fan_Speed[32]	Speed of Fan 32			99	IV	Read	0	40258	Input	2
BMS_Fan_Speed[33]	Speed of Fan 33			100	IV	Read	0	40260	Input	2
BMS_Fan_Speed[34]	Speed of Fan 34			101	IV	Read	0	40262	Input	2
BMS_Fan_Speed[35]	Speed of Fan 35			102	IV	Read	0	40264	Input	2
BMS_Fan_Speed[36]	Speed of Fan 36			103	IV	Read	0	40266	Input	2
BMS_Fan_Speed[37]	Speed of Fan 37			104	IV	Read	0	40268	Input	2
BMS_Fan_Speed[38]	Speed of Fan 38			105	IV	Read	0	40270	Input	2
BMS_Fan_Speed[39]	Speed of Fan 39			106	IV	Read	0	40272	Input	2
BMS_Fan_Speed[40]	Speed of Fan 40			107	IV	Read	0	40274	Input	2
BMS_Fan_Speed[41]	Speed of Fan 41			108	IV	Read	0	40276	Input	2
BMS_Fan_Speed[42]	Speed of Fan 42			109	IV	Read	0	40278	Input	2
BMS_Fan_Speed[43]	Speed of Fan 43			110	IV	Read	0	40280	Input	2
BMS_Fan_Speed[44]	Speed of Fan 44			111	IV	Read	0	40282	Input	2
BMS_Fan_Speed[45]	Speed of Fan 45			112	IV	Read	0	40284	Input	2
BMS_Fan_Speed[46]	Speed of Fan 46			113	IV	Read	0	40286	Input	2
BMS_Fan_Speed[47]	Speed of Fan 47			114	IV	Read	0	40288	Input	2
BMS_Fan_Speed[48]	Speed of Fan 48			115	IV	Read	0	40290	Input	2
BMS_Fan_Speed[49]	Speed of Fan 49			116	IV	Read	0	40292	Input	2
BMS_Fan_Speed[50]	Speed of Fan 50			117	IV	Read	0	40294	Input	2
BMS_Fan_Speed[51]	Speed of Fan 51			118	IV	Read	0	40296	Input	2
BMS_Fan_Speed[52]	Speed of Fan 52			119	IV	Read	0	40298	Input	2
BMS_Fan_Speed[53]	Speed of Fan 53			120	IV	Read	0	40300	Input	2
BMS_Fan_Speed[54]	Speed of Fan 54			121	IV	Read	0	40302	Input	2



Variable	Description	Active Text	Inactive Text	BACnet				MODBUS		
				Object Instance	Object Type	Access	Hyst	Index	Register Type	Size
BMS_Fan_Speed[55]	Speed of Fan 55			122	IV	Read	0	40304	Input	2
BMS_Fan_Speed[56]	Speed of Fan 56			123	IV	Read	0	40306	Input	2
BMS_Fan_Speed[57]	Speed of Fan 57			124	IV	Read	0	40308	Input	2
BMS_Fan_Speed[58]	Speed of Fan 58			125	IV	Read	0	40310	Input	2
BMS_Fan_Speed[59]	Speed of Fan 59			126	IV	Read	0	40312	Input	2
BMS_Fan_Speed[60]	Speed of Fan 60			127	IV	Read	0	40314	Input	2
BMS_Fan_Speed[61]	Speed of Fan 61			128	IV	Read	0	40316	Input	2
BMS_Fan_Speed[62]	Speed of Fan 62			129	IV	Read	0	40318	Input	2
BMS_Fan_Speed[63]	Speed of Fan 63			130	IV	Read	0	40320	Input	2
BMS_Fan_Speed[64]	Speed of Fan 64			131	IV	Read	0	40322	Input	2

MultiState Values										
Variable	Description	Active Text	Inactive Text	BACnet				MODBUS		
				Object Instance	Object Type	Access	Hyst	Index	Register Type	Size
UnitStatus	Array status	1	ON	1	MSV	Read/Write	0	30000	Holding	2
		2	OFF BY ALARM			Read/Write	0			
		3	OFF BY BMS			Read/Write	0			
		4	OFF BY SCHEDULE			Read/Write	0			
		5	OFF BY DIN/ SAFETY INPUT			Read/Write	0			
		6	OFF BY KEYPAD/ HOA			Read/Write	0			
		7	MANUAL MODE			Read/Write	0			
		8	FIREMAN OVERRIDE			Read/Write	0			
		9	FIREMAN OVERRIDE			Read/Write	0			
		10	IN FAILSAFE MODE			Read/Write	0			
Fan_Unit_Display_Type	Fan Speed Display Units	1	RPM	2	MSV	Read/Write	0	30012	Holding	2
		2	PERCENT			Read/Write	0			
		3	HZ			Read/Write	0			
BMS_Fan_Run_Status[1]	Run Status of Fan 1	1	OFF BY ALARM	20	MSV	Read/Write	0	40132	Input	1
		2	OFF			Read/Write	0			
		3	ON			Read/Write	0			
BMS_Fan_Run_Status[2]	Run Status of Fan 2	1	OFF BY ALARM	21	MSV	Read/Write	0	40133	Input	1
		2	OFF			Read/Write	0			
		3	ON			Read/Write	0			
BMS_Fan_Run_Status[3]	Run Status of Fan 3	1	OFF BY ALARM	22	MSV	Read/Write	0	40134	Input	1
		2	OFF			Read/Write	0			
		3	ON			Read/Write	0			
BMS_Fan_Run_Status[4]	Run Status of Fan 4	1	OFF BY ALARM	23	MSV	Read/Write	0	40135	Input	1
		2	OFF			Read/Write	0			
		3	ON			Read/Write	0			





Variable	Description	Active Text	Inactive Text	BACnet				MODBUS		
				Object Instance	Object Type	Access	Hyst	Index	Register Type	Size
BMS_Fan_Run_Status[5]	Run Status of Fan 5	1	OFF BY ALARM	24	MSV	Read/Write	0	40136	Input	1
		2	OFF			Read/Write	0			
		3	ON			Read/Write	0			
BMS_Fan_Run_Status[6]	Run Status of Fan 6	1	OFF BY ALARM	25	MSV	Read/Write	0	40137	Input	1
		2	OFF			Read/Write	0			
		3	ON			Read/Write	0			
BMS_Fan_Run_Status[7]	Run Status of Fan 7	1	OFF BY ALARM	26	MSV	Read/Write	0	40138	Input	1
		2	OFF			Read/Write	0			
		3	ON			Read/Write	0			
BMS_Fan_Run_Status[8]	Run Status of Fan 8	1	OFF BY ALARM	27	MSV	Read/Write	0	40139	Input	1
		2	OFF			Read/Write	0			
		3	ON			Read/Write	0			
BMS_Fan_Run_Status[9]	Run Status of Fan 9	1	OFF BY ALARM	28	MSV	Read/Write	0	40140	Input	1
		2	OFF			Read/Write	0			
		3	ON			Read/Write	0			
BMS_Fan_Run_Status[10]	Run Status of Fan 10	1	OFF BY ALARM	29	MSV	Read/Write	0	40141	Input	1
		2	OFF			Read/Write	0			
		3	ON			Read/Write	0			
BMS_Fan_Run_Status[11]	Run Status of Fan 11	1	OFF BY ALARM	30	MSV	Read/Write	0	40142	Input	1
		2	OFF			Read/Write	0			
		3	ON			Read/Write	0			
BMS_Fan_Run_Status[12]	Run Status of Fan 12	1	OFF BY ALARM	31	MSV	Read/Write	0	40143	Input	1
		2	OFF			Read/Write	0			
		3	ON			Read/Write	0			
BMS_Fan_Run_Status[13]	Run Status of Fan 13	1	OFF BY ALARM	32	MSV	Read/Write	0	40144	Input	1
		2	OFF			Read/Write	0			
		3	ON			Read/Write	0			

Variable	Description	Active Text	Inactive Text	BACnet				MODBUS		
				Object Instance	Object Type	Access	Hyst	Index	Register Type	Size
BMS_Fan_Run_Status[14]	Run Status of Fan 14	1	OFF BY ALARM	33	MSV	Read/Write	0	40145	Input	1
		2	OFF			Read/Write	0			
		3	ON			Read/Write	0			
BMS_Fan_Run_Status[15]	Run Status of Fan 15	1	OFF BY ALARM	34	MSV	Read/Write	0	40146	Input	1
		2	OFF			Read/Write	0			
		3	ON			Read/Write	0			
BMS_Fan_Run_Status[16]	Run Status of Fan 16	1	OFF BY ALARM	35	MSV	Read/Write	0	40147	Input	1
		2	OFF			Read/Write	0			
		3	ON			Read/Write	0			
BMS_Fan_Run_Status[17]	Run Status of Fan 17	1	OFF BY ALARM	36	MSV	Read/Write	0	40148	Input	1
		2	OFF			Read/Write	0			
		3	ON			Read/Write	0			
BMS_Fan_Run_Status[18]	Run Status of Fan 18	1	OFF BY ALARM	37	MSV	Read/Write	0	40149	Input	1
		2	OFF			Read/Write	0			
		3	ON			Read/Write	0			
BMS_Fan_Run_Status[19]	Run Status of Fan 19	1	OFF BY ALARM	38	MSV	Read/Write	0	40150	Input	1
		2	OFF			Read/Write	0			
		3	ON			Read/Write	0			
BMS_Fan_Run_Status[20]	Run Status of Fan 20	1	OFF BY ALARM	39	MSV	Read/Write	0	40151	Input	1
		2	OFF			Read/Write	0			
		3	ON			Read/Write	0			
BMS_Fan_Run_Status[21]	Run Status of Fan 21	1	OFF BY ALARM	40	MSV	Read/Write	0	40152	Input	1
		2	OFF			Read/Write	0			
		3	ON			Read/Write	0			
BMS_Fan_Run_Status[22]	Run Status of Fan 22	1	OFF BY ALARM	41	MSV	Read/Write	0	40153	Input	1
		2	OFF			Read/Write	0			
		3	ON			Read/Write	0			

Variable	Description	Active Text	Inactive Text	BACnet				MODBUS		
				Object Instance	Object Type	Access	Hyst	Index	Register Type	Size
BMS_Fan_Run_Status[23]	Run Status of Fan 23	1	OFF BY ALARM	42	MSV	Read/Write	0	40154	Input	1
		2	OFF			Read/Write	0			
		3	ON			Read/Write	0			
BMS_Fan_Run_Status[24]	Run Status of Fan 24	1	OFF BY ALARM	43	MSV	Read/Write	0	40155	Input	1
		2	OFF			Read/Write	0			
		3	ON			Read/Write	0			
BMS_Fan_Run_Status[25]	Run Status of Fan 25	1	OFF BY ALARM	44	MSV	Read/Write	0	40156	Input	1
		2	OFF			Read/Write	0			
		3	ON			Read/Write	0			
BMS_Fan_Run_Status[26]	Run Status of Fan 26	1	OFF BY ALARM	45	MSV	Read/Write	0	40157	Input	1
		2	OFF			Read/Write	0			
		3	ON			Read/Write	0			
BMS_Fan_Run_Status[27]	Run Status of Fan 27	1	OFF BY ALARM	46	MSV	Read/Write	0	40158	Input	1
		2	OFF			Read/Write	0			
		3	ON			Read/Write	0			
BMS_Fan_Run_Status[28]	Run Status of Fan 28	1	OFF BY ALARM	47	MSV	Read/Write	0	40159	Input	1
		2	OFF			Read/Write	0			
		3	ON			Read/Write	0			
BMS_Fan_Run_Status[29]	Run Status of Fan 29	1	OFF BY ALARM	48	MSV	Read/Write	0	40160	Input	1
		2	OFF			Read/Write	0			
		3	ON			Read/Write	0			
BMS_Fan_Run_Status[30]	Run Status of Fan 30	1	OFF BY ALARM	49	MSV	Read/Write	0	40161	Input	1
		2	OFF			Read/Write	0			
		3	ON			Read/Write	0			
BMS_Fan_Run_Status[31]	Run Status of Fan 31	1	OFF BY ALARM	50	MSV	Read/Write	0	40162	Input	1
		2	OFF			Read/Write	0			
		3	ON			Read/Write	0			

Variable	Description	Active Text	Inactive Text	BACnet				MODBUS		
				Object Instance	Object Type	Access	Hyst	Index	Register Type	Size
BMS_Fan_Run_Status[32]	Run Status of Fan 32	1	OFF BY ALARM	51	MSV	Read/Write	0	40163	Input	1
		2	OFF			Read/Write	0			
		3	ON			Read/Write	0			
BMS_Fan_Run_Status[33]	Run Status of Fan 33	1	OFF BY ALARM	52	MSV	Read/Write	0	40164	Input	1
		2	OFF			Read/Write	0			
		3	ON			Read/Write	0			
BMS_Fan_Run_Status[34]	Run Status of Fan 34	1	OFF BY ALARM	53	MSV	Read/Write	0	40165	Input	1
		2	OFF			Read/Write	0			
		3	ON			Read/Write	0			
BMS_Fan_Run_Status[35]	Run Status of Fan 35	1	OFF BY ALARM	54	MSV	Read/Write	0	40166	Input	1
		2	OFF			Read/Write	0			
		3	ON			Read/Write	0			
BMS_Fan_Run_Status[36]	Run Status of Fan 36	1	OFF BY ALARM	55	MSV	Read/Write	0	40167	Input	1
		2	OFF			Read/Write	0			
		3	ON			Read/Write	0			
BMS_Fan_Run_Status[37]	Run Status of Fan 37	1	OFF BY ALARM	56	MSV	Read/Write	0	40168	Input	1
		2	OFF			Read/Write	0			
		3	ON			Read/Write	0			
BMS_Fan_Run_Status[38]	Run Status of Fan 38	1	OFF BY ALARM	57	MSV	Read/Write	0	40169	Input	1
		2	OFF			Read/Write	0			
		3	ON			Read/Write	0			
BMS_Fan_Run_Status[39]	Run Status of Fan 39	1	OFF BY ALARM	58	MSV	Read/Write	0	40170	Input	1
		2	OFF			Read/Write	0			
		3	ON			Read/Write	0			
BMS_Fan_Run_Status[40]	Run Status of Fan 40	1	OFF BY ALARM	59	MSV	Read/Write	0	40171	Input	1
		2	OFF			Read/Write	0			
		3	ON			Read/Write	0			



Variable	Description	Active Text	Inactive Text	BACnet				MODBUS		
				Object Instance	Object Type	Access	Hyst	Index	Register Type	Size
BMS_Fan_Run_Status[41]	Run Status of Fan 41	1	OFF BY ALARM	60	MSV	Read/Write	0	40172	Input	1
		2	OFF			Read/Write	0			
		3	ON			Read/Write	0			
BMS_Fan_Run_Status[42]	Run Status of Fan 42	1	OFF BY ALARM	61	MSV	Read/Write	0	40173	Input	1
		2	OFF			Read/Write	0			
		3	ON			Read/Write	0			
BMS_Fan_Run_Status[43]	Run Status of Fan 43	1	OFF BY ALARM	62	MSV	Read/Write	0	40174	Input	1
		2	OFF			Read/Write	0			
		3	ON			Read/Write	0			
BMS_Fan_Run_Status[44]	Run Status of Fan 44	1	OFF BY ALARM	63	MSV	Read/Write	0	40175	Input	1
		2	OFF			Read/Write	0			
		3	ON			Read/Write	0			
BMS_Fan_Run_Status[45]	Run Status of Fan 45	1	OFF BY ALARM	64	MSV	Read/Write	0	40176	Input	1
		2	OFF			Read/Write	0			
		3	ON			Read/Write	0			
BMS_Fan_Run_Status[46]	Run Status of Fan 46	1	OFF BY ALARM	65	MSV	Read/Write	0	40177	Input	1
		2	OFF			Read/Write	0			
		3	ON			Read/Write	0			
BMS_Fan_Run_Status[47]	Run Status of Fan 47	1	OFF BY ALARM	66	MSV	Read/Write	0	40178	Input	1
		2	OFF			Read/Write	0			
		3	ON			Read/Write	0			
BMS_Fan_Run_Status[48]	Run Status of Fan 48	1	OFF BY ALARM	67	MSV	Read/Write	0	40179	Input	1
		2	OFF			Read/Write	0			
		3	ON			Read/Write	0			
BMS_Fan_Run_Status[49]	Run Status of Fan 49	1	OFF BY ALARM	68	MSV	Read/Write	0	40180	Input	1
		2	OFF			Read/Write	0			
		3	ON			Read/Write	0			

Variable	Description	Active Text	Inactive Text	BACnet				MODBUS		
				Object Instance	Object Type	Access	Hyst	Index	Register Type	Size
BMS_Fan_Run_Status[50]	Run Status of Fan 50	1	OFF BY ALARM	69	MSV	Read/Write	0	40181	Input	1
		2	OFF			Read/Write	0			
		3	ON			Read/Write	0			
BMS_Fan_Run_Status[51]	Run Status of Fan 51	1	OFF BY ALARM	70	MSV	Read/Write	0	40182	Input	1
		2	OFF			Read/Write	0			
		3	ON			Read/Write	0			
BMS_Fan_Run_Status[52]	Run Status of Fan 52	1	OFF BY ALARM	71	MSV	Read/Write	0	40183	Input	1
		2	OFF			Read/Write	0			
		3	ON			Read/Write	0			
BMS_Fan_Run_Status[53]	Run Status of Fan 53	1	OFF BY ALARM	72	MSV	Read/Write	0	40184	Input	1
		2	OFF			Read/Write	0			
		3	ON			Read/Write	0			
BMS_Fan_Run_Status[54]	Run Status of Fan 54	1	OFF BY ALARM	73	MSV	Read/Write	0	40185	Input	1
		2	OFF			Read/Write	0			
		3	ON			Read/Write	0			
BMS_Fan_Run_Status[55]	Run Status of Fan 55	1	OFF BY ALARM	74	MSV	Read/Write	0	40186	Input	1
		2	OFF			Read/Write	0			
		3	ON			Read/Write	0			
BMS_Fan_Run_Status[56]	Run Status of Fan 56	1	OFF BY ALARM	75	MSV	Read/Write	0	40187	Input	1
		2	OFF			Read/Write	0			
		3	ON			Read/Write	0			
BMS_Fan_Run_Status[57]	Run Status of Fan 57	1	OFF BY ALARM	76	MSV	Read/Write	0	40188	Input	1
		2	OFF			Read/Write	0			
		3	ON			Read/Write	0			
BMS_Fan_Run_Status[58]	Run Status of Fan 58	1	OFF BY ALARM	77	MSV	Read/Write	0	40189	Input	1
		2	OFF			Read/Write	0			
		3	ON			Read/Write	0			

Variable	Description	Active Text	Inactive Text	BACnet				MODBUS		
				Object Instance	Object Type	Access	Hyst	Index	Register Type	Size
BMS_Fan_Run_Status[59]	Run Status of Fan 59	1	OFF BY ALARM	78	MSV	Read/Write	0	40190	Input	1
		2	OFF			Read/Write	0			
		3	ON			Read/Write	0			
BMS_Fan_Run_Status[60]	Run Status of Fan 60	1	OFF BY ALARM	79	MSV	Read/Write	0	40191	Input	1
		2	OFF			Read/Write	0			
		3	ON			Read/Write	0			
BMS_Fan_Run_Status[61]	Run Status of Fan 61	1	OFF BY ALARM	80	MSV	Read/Write	0	40192	Input	1
		2	OFF			Read/Write	0			
		3	ON			Read/Write	0			
BMS_Fan_Run_Status[62]	Run Status of Fan 62	1	OFF BY ALARM	81	MSV	Read/Write	0	40193	Input	1
		2	OFF			Read/Write	0			
		3	ON			Read/Write	0			
BMS_Fan_Run_Status[63]	Run Status of Fan 63	1	OFF BY ALARM	82	MSV	Read/Write	0	40194	Input	1
		2	OFF			Read/Write	0			
		3	ON			Read/Write	0			
BMS_Fan_Run_Status[64]	Run Status of Fan 64	1	OFF BY ALARM	83	MSV	Read/Write	0	40195	Input	1
		2	OFF			Read/Write	0			
		3	ON			Read/Write	0			



# Maintenance Log

Date \_\_\_\_\_ Time \_\_\_\_\_ AM/PM  
Notes: \_\_\_\_\_

\_\_\_\_\_  
\_\_\_\_\_  
\_\_\_\_\_

Date \_\_\_\_\_ Time \_\_\_\_\_ AM/PM  
Notes: \_\_\_\_\_

\_\_\_\_\_  
\_\_\_\_\_  
\_\_\_\_\_

Date \_\_\_\_\_ Time \_\_\_\_\_ AM/PM  
Notes: \_\_\_\_\_

\_\_\_\_\_  
\_\_\_\_\_  
\_\_\_\_\_

Date \_\_\_\_\_ Time \_\_\_\_\_ AM/PM  
Notes: \_\_\_\_\_

\_\_\_\_\_  
\_\_\_\_\_  
\_\_\_\_\_

Date \_\_\_\_\_ Time \_\_\_\_\_ AM/PM  
Notes: \_\_\_\_\_

\_\_\_\_\_  
\_\_\_\_\_  
\_\_\_\_\_

Date \_\_\_\_\_ Time \_\_\_\_\_ AM/PM  
Notes: \_\_\_\_\_

\_\_\_\_\_  
\_\_\_\_\_  
\_\_\_\_\_

Date \_\_\_\_\_ Time \_\_\_\_\_ AM/PM  
Notes: \_\_\_\_\_

\_\_\_\_\_  
\_\_\_\_\_  
\_\_\_\_\_

Date \_\_\_\_\_ Time \_\_\_\_\_ AM/PM  
Notes: \_\_\_\_\_

\_\_\_\_\_  
\_\_\_\_\_  
\_\_\_\_\_

## Our Commitment

*As a result of our commitment to continuous improvement, Greenheck reserves the right to change specifications without notice.*

Product warranties can be found online at [Greenheck.com](http://Greenheck.com), either on the specific product page or in the literature section of the website at [Greenheck.com/Resources/Library/Literature](http://Greenheck.com/Resources/Library/Literature).

Greenheck's HPA and MOA catalog provides additional information describing the equipment, fan performance, available accessories, and specification data.

AMCA Publication 410-96, Safety Practices for Users and Installers of Industrial and Commercial Fans, provides additional safety information. This publication can be obtained from AMCA International, Inc. at [www.amca.org](http://www.amca.org).

