

Installation, Operation and Maintenance Manual

Please read and save these instructions for future reference. Read carefully before attempting to assemble, install, operate or maintain the product described. Protect yourself and others by observing all safety information. Failure to comply with these instructions will result in voiding of the product warranty and may result in personal injury and/or property damage.

The multispeed analog control combines convenience and versatility, offering essential control features in a compact design. It includes a 0–10V potentiometer for precise speed adjustment across the fan’s full operating range, along with a 3-position dial for Forward, Off, and Reverse operation. Its clean, surface-mounted design provides a professional, user-friendly appearance suitable for a variety of applications. It is compatible with overhead HVLS models DS-3 and DS-6.

NOTE: The multispeed analog control can control only one fan at a time. For additional assistance, contact your local sales representative or the manufacturer directly.



General Information

IMPORTANT SAFETY INSTRUCTIONS

Only qualified personnel should install this fan. Personnel should have a clear understanding of these instructions and should be aware of general safety precautions. Improper installation can result in electric shock, possible injury due to coming in contact with moving parts, as well as other potential hazards. Other considerations may be required if high winds or seismic activity are present. If more information is needed, contact a licensed professional engineer before moving forward.

1. Follow all local electrical and safety codes, as well as the National Electrical Code (NEC) and the National Fire Protection Agency (ANSI/NFPA 70), where applicable. Follow the Canadian Electric Code (CEC) in Canada.
2. Verify that the power source is compatible with the equipment.

DANGER

Always disconnect, lock, and tag power source before installing or servicing. Failure to disconnect power source can result in fire, shock or serious injury.

CAUTION

When servicing the fan, motor may be hot enough to cause pain or injury. Allow motor to cool before servicing.

DANGER

Pour écarter les risques d’incendie, de choc électrique ou de blessure grave, veiller à toujours débrancher, verrouiller et étiqueter la source de courant avant l’installation ou l’entretien.

ATTENTION

Lors de toute intervention sur la soufflante, le moteur peut être suffisamment chaud pour provoquer une douleur voire une blessure. Laisser le moteur refroidir avant toute maintenance.

Receiving

Upon receiving the product, check to ensure all items are accounted for by referencing the delivery receipt or packing list. Inspect each crate or carton for shipping damage before accepting delivery. Alert the carrier of any damage detected. The customer will make a notation of damage (or shortage of items) on the delivery receipt and all copies of the bill of lading which is countersigned by the delivering carrier. If damaged, immediately contact your local representative. Any physical damage to the unit after acceptance is not the responsibility of the manufacturer.

Unpacking

Verify that all required parts and the correct quantity of each item have been received using the component list. If any items are missing, report shortages to your local representative to arrange for obtaining missing parts. Due to availability of transportation and truck space all items for the unit may not be shipped together. Confirmation of shipment(s) must be limited to only items on the bill of lading.

Storage

Controls are protected against damage during shipment. If the control cannot be installed and operated immediately, precautions need to be taken to prevent deterioration of the control during storage. The user assumes responsibility of the control while in storage. The manufacturer will not be responsible for damage during storage. These suggestions are provided solely as a convenience to the user.

Installation

Required Loose Components (Not Included):

- 2x4 in. Single Gang Junction Box (1)
- 1-to-1 Inline Splice Lever Connector 24-12AWG (5)

Hardware/Tools Needed (Not Included):

- # 2 Phillips Head Screwdriver
- 1/8 in. Phillips Head Screwdriver
- 2.0 mm Flathead Screwdriver
- Wire Strippers
- Multi-Meter (Optional)

IMPORTANT: Do not apply power until the mechanical installation, fire-alarm relay installation, communication wiring, and fan control installation are complete.

NOTE: Before installing the multispeed control, confirm commissioning mode has been run successfully to verify the fan components are in working order. Refer to the fan's Installation, Operation, and Maintenance (IOM) manual for the commissioning sequence.

1. Identify mounting location for the control junction box (by others) per the building plans.
2. Route the shielded 18/6 cable from the junction box at the floor level to the loose pigtails at the top of the fan.

The ideal environment for the storage of controls is indoors, above grade, in a low humidity atmosphere which is sealed to prevent the entry of blowing dust, rain or snow. Care must be taken to protect control from dirt, moisture, and extreme temperature during storage.

NOTE: Improper storage which results in damage to the product will void the warranty.

Control Components

Verify that all of the following parts and hardware have been received prior to beginning installation. Contact your local representative or the manufacturer if replacement parts are required.

NOTE: Additional parts (provided by others) may be required to complete the control installation, including additional wiring and hardware for mounting the control to the building structure.

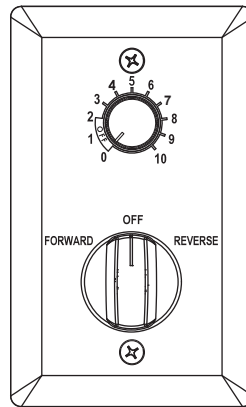

Multispeed Control (1)



#6 – 32 x 7/16 in.
Phillips Head Screw (2)

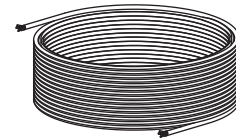

Shielded 18/6
Control Cable (1)

3. Connect the shielded 18/6 wiring to the fan pigtails as shown in the image below. All wiring shall be installed in accordance with appropriate local electrical codes and industry standards pertaining to the installation environment.

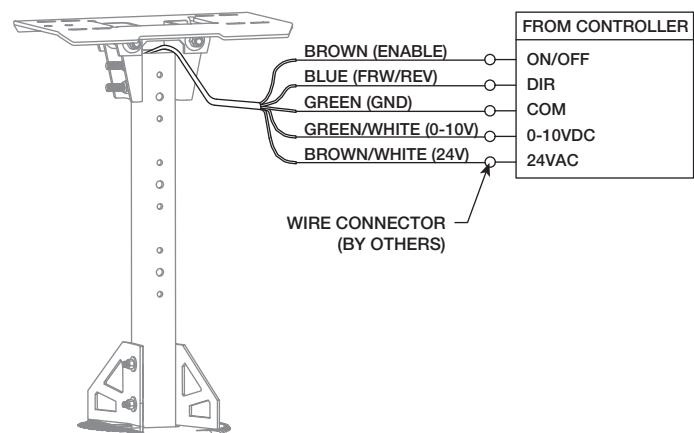

4. Confirm factory installed drive terminations are landed in accordance with the multispeed control in the Fan Networking and Pre-Startup section of the fan's Installation, Operation, and Maintenance (IOM) manual.

IMPORTANT: Make sure the drive is set to the appropriate control mode, blade count, and fan size on the rotary dials. Incorrect drive settings could result in inoperable or unsafe operation.

- At the floor level, terminate the shielded 18/6 wire strands into the appropriate terminals.

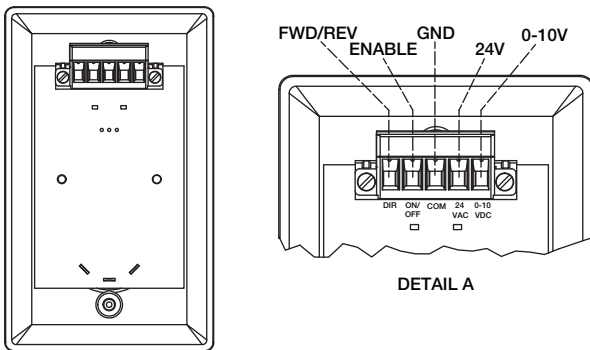

All wiring connections are from the fan to the back side of the control.

- Connect "Enable" to "ON/OFF"
 - Connect "FWD/REV" to "DIR"
 - Connect "GND" to "COM"
 - Connect "0-10V" to "0-10 VDC"
 - Connect "24V" to "24 VAC".
- Secure the multispeed control to the junction box using the provided #6 – 32 x 7/16 in. Phillips head screws.

NOTE: To adjust the minimum and maximum limits on the back of the control, refer to section "Min/Max Setting Adjustments" on page 4 before fastening the control to the junction box.

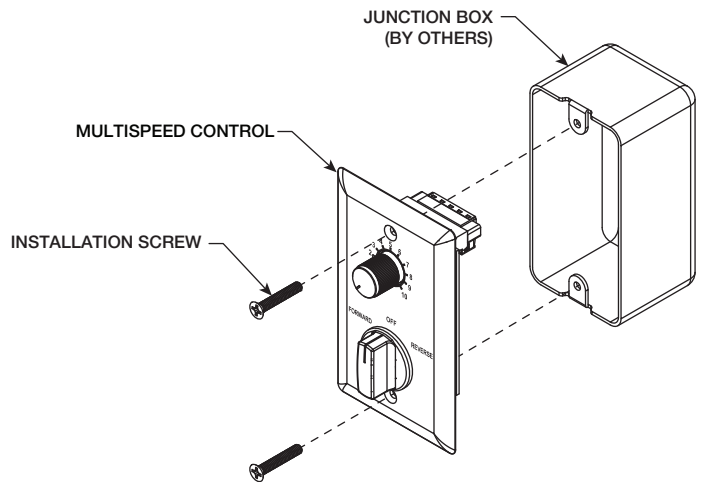

IMPORTANT: Controls and HVLS fans must be installed using the supplied 18/6 communication cable or an equivalent 18AWG, 6-conductor bare copper, shielded plenum (CMP) cable with an integral drain wire. Control wiring characteristic impedance should not exceed 50 ohms. The maximum allowable cable length should not exceed 200 ft order to prevent signal loss and erratic operation.

IMPORTANT: All wiring should be done in accordance with the latest edition of the National Electrical Code (ANSI/NFPA70) and any local codes that may apply. In Canada, wiring should be done in accordance with the Canadian Electrical Code.

Start-Up and Operation

Control Start-Up

- Before applying power to the fan, confirm the control's bottom dial is set to the "Off" position.
- For direction control, apply power to the fan and turn the bottom directional dial counterclockwise to the "Forward" position. Then turn the potentiometer speed dial clockwise past position 2 to initiate fan rotation. After a few seconds, the fan will begin to spin forward.

NOTE: During operation, the small LED light on the drive illuminates purple when the fan is receiving a command from the multispeed control.

- For speed control, turn the potentiometer speed dial clockwise incrementally through position 10 to increase fan speed. Allow 20 to 30 seconds for the fan to ramp to the selected speed. Turn the dial counterclockwise to reduce speed. The fan will shut off at any position below 2.

NOTE: If the fan does not rotate when given a speed command greater than "2" while in "Forward" or "Reverse" position, refer back to the Installation section and check the communication-wiring connections.

Reference the fan's Installation, Operation, and Maintenance (IOM) manual for information on the LED light status colors in the normal operation or for flashing LED error code references.

Control Functionality

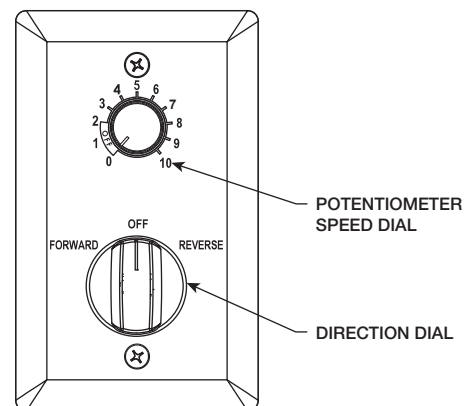

Directional Dial

- FORWARD = Commands the fan to spin Forward.
- REVERSE = Commands the fan to spin Reverse.
- OFF = Commands the fan to turn Off.

Potentiometer Speed Dial

- Positions 0 to 2 sets the fan speed to Off.
- Positions 2 through 10 sets the fan speed to the % shown in the table to the right.

Default Speed Settings

| Dial Position | % of Max Speed |
|---------------|----------------|
| 0 | 0% |
| 1 | 0% |
| 2 | 20% |
| 3 | 30% |
| 4 | 40% |
| 5 | 50% |
| 6 | 60% |
| 7 | 70% |
| 8 | 80% |
| 9 | 90% |
| 10 | 100% |

Min/Max Setting Adjustments

NOTE: The multispeed control features upper and lower limit programming to more precisely set the 0-10v output signal to further dial in the speed control of the fan.

Calibration Process

1. Connect one multimeter probe to the 0-10v test point labeled TP1 in the top right corner of the PCB and connect other multimeter probe to the ground test point labeled TP2 in the top left corner of the PCB.
2. Identify the UPPER and LOWER LIMIT pushbuttons located on the back side of the control. The module is set up to program the UPPER LIMIT first.

To program the UPPER LIMIT, press and hold the pushbutton labeled “UPPER LIMIT” until the LED illuminates and adjust the directional dial until the multimeter reads the desired output voltage. Once desired voltage is reached, release the pushbutton to lock in the UPPER LIMIT.
3. To program the LOWER LIMIT, press and hold the pushbutton labeled “LOWER LIMIT” until the LED illuminates and adjust the potentiometer speed dial to the desired voltage. Once desired voltage is reached, release the pushbutton to lock in the LOWER LIMIT.

NOTE: Upper and lower limits can only be within 0.5v of each other.

4. Test the upper and lower limits by increasing the fan speed beyond the upper limit and verifying that the multimeter voltage remains constant above the set upper limit. Then decrease the fan speed below the lower limit and verify that the multimeter voltage remains constant below the set lower limit.

IMPORTANT: To reset to factory default 0-10v limits, press and hold both the “UPPER LIMIT” and “LOWER LIMIT” pushbuttons simultaneously until the LED illuminates, then release both buttons. The module has now been reset to factory defaults.

5. Turn off the fan by rotating the lower dial to the “OFF” position. Secure the multispeed control to the junction box using the provided #6 - 32 x 7/16 in. Phillips head screws.

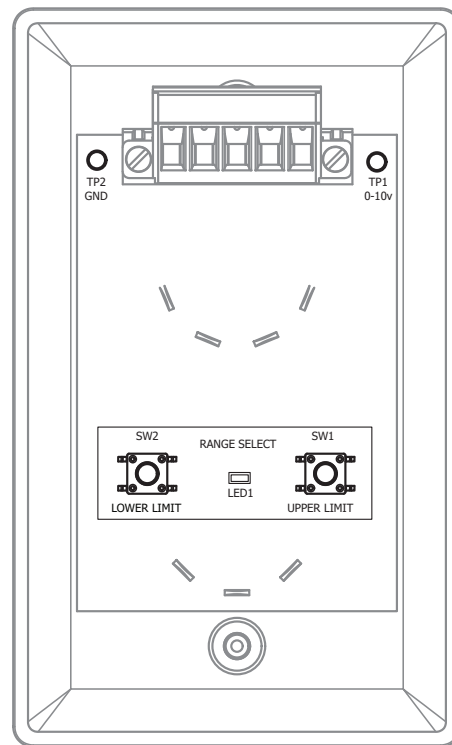

Our Commitment

As a result of our commitment to continuous improvement, Greenheck reserves the right to change specifications without notice.

Product warranties can be found online at Greenheck.com, either on the specific product page or in the literature section of the website at Greenheck.com/Resources/Library/Literature.

AMCA Publication 410-96, Safety Practices for Users and Installers of Industrial and Commercial Fans, provides additional safety information. This publication can be obtained from AMCA International, Inc. at www.amca.org.

